

# INSTALLATION GUIDE



## **5 SERIES**

Custom Panel Built-In Bottom-Freezer Refrigerator

*FDBB5363E / CFDBB5363E*

# Table of Contents

Warnings & Important Information	3
Dimensions and Specifications (36")	5
Cutout Dimensions (36")	7
Anti-Tip Dimensions (36")	8
Overlay Dimensions (36")	9
Custom Grille Dimensions (36")	10
Cabinet Information	12
Custom Side Panel Dimensions	13
Custom Panel General Information	14
Custom Door Panel Installation – (Refrigerator or Freezer)	14
Door Trim Insert	17
Custom Panel Hinge Cutout	17
Custom Grille Installation	18
General Information	20
Unpacking & Moving	21
Installation	22
Hinge Adjustment	23
Kickplate Installation	26
Door Stop Adjustment	26
Water Filter System Specifications	27
Final Installation	28
Performance Checklist	29
Control Panels	30
Service & Registration	31

# IMPORTANT – Please Read and Follow

- Make sure that incoming voltage is the same as unit rating. An electric rating plate specifying voltage, frequency, wattage, amperage, and phase is attached to the product.
- To reduce the risk of fire, electrical shock, or injury to persons, installation work and electrical wiring must be done by a qualified technician in accordance with all applicable codes and standards, including fire-rated construction.
- The installer should leave these instructions with the consumer who should retain them for local inspector's use and for future reference.

### It is your responsibility to:

- Comply with installation specifications and dimensions.
- Properly install unit.
- Remove any moldings or decorative panels that prevent the unit from being serviced.
- Make sure that you have these materials (not provided with your unit), which are necessary for proper installation:
  - 1/4" (6 mm) copper tubing with shutoff valve
  - 6 – #8 x 3" (7.6 cm) wood screws (longer screws may be required)
  - 1– Saddle valve (**DO NOT** use self-piercing feature of the valve)
- Assure that floor will support unit, door panels and contents (approximately 1200 pounds [540 kg]).
- Provide a properly grounded electrical outlet.
- Assure that location will permit appliance doors to open a minimum of 90°.

**Your safety and the safety of others is very important.**

We have provided many important safety messages in this manual and on your appliance. **ALWAYS** read and obey all safety messages.



This is the safety alert symbol. This symbol alerts you to hazards that can kill or hurt you and others.

All safety messages will be preceded by the safety alert symbol and the word "DANGER" or "WARNING."

These words mean:

## **DANGER**

**Hazards or unsafe practices which WILL result in severe personal injury or death**

## **WARNING**

**Hazards or unsafe practices which COULD result in severe personal injury or death**

All safety messages will identify the hazard, tell you how to reduce the chance of injury, and tell you what can happen if the instructions are not followed.

# IMPORTANT—Please Read and Follow!

**A GFI shall be used if required by NFPA-70 (National Electric Code), federal/state/local laws, or local ordinances.**

- The required use of a GFI is normally related to the location of a receptacle with respect to any significant sources of water or moisture.
- Viking Range, LLC will NOT warranty any problems resulting from GFI outlets which are not installed properly or do not meet the requirements below.

**If the use of a GFI is required**, it should be:

- Of the receptacle type (breaker type or portable type NOT recommended)
- Used with permanent wiring only (temporary or portable wiring NOT recommended)
- On a dedicated circuit (no other receptacles, switches or loads in the circuit)
- Connected to a standard breaker of appropriate size (GFI breaker of the same size NOT recommended)
- Rated for Class A (5 mA +/- 1 mA trip current) as per UL 943 standard)
- In good condition and free from any loose-fitting gaskets (if applicable in outdoor situations)
- Protected from moisture (water, steam, high humidity) as much as reasonably possible

**⚠ WARNING**

**TIP OVER HAZARD**  
Appliance is top heavy and tips easily when not completely installed. Keep doors closed until appliance is completely installed and secured per installation instructions.

Use two or more people to move and install appliance. Failure to do so can result in death or serious injury.



**⚠ WARNING**

**ELECTRICAL SHOCK HAZARD**  
Disconnect power or turn power disconnect switch to OFF position before removing top grille. Failure to do so can result in death or electric shock.



Most of the unit's weight is at the top. Extra care is needed when moving the unit to prevent tipping. Use cardboard shipping material or plywood under unit until it is installed in the operating position to protect floor surface.

# Dimensions (Bottom-Freezer)

## 36" Bottom-Freezer

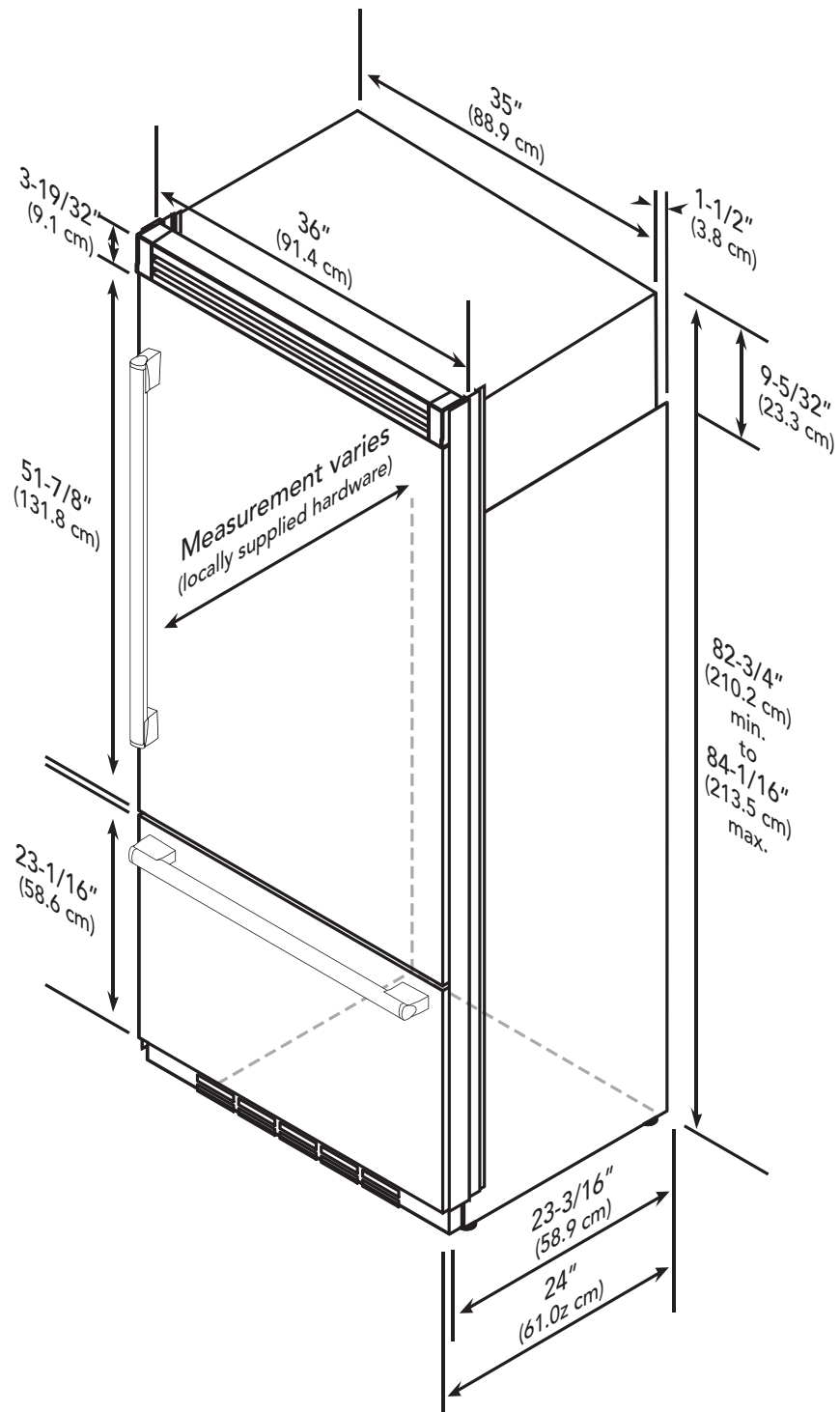

## Specifications (Bottom-Freezer)

<b>36" Bottom-Freezer</b>	
<b>Description</b>	<b>FDBB/CFDBB</b>
Overall width	36" (91.5 cm)
Overall height (from bottom)	82-3/4" (210.2 cm) min. to 84-1/16" (213.5 cm) max.
Overall depth (from rear)	To front edge of side trim: 23-3/16" (58.9 cm) To front of top grille: 24" (61.0 cm)
Cutout width	36" (91.5 cm)
Cutout height	82-7/8" (210.5 cm) min. to 84-1/16" (213.5 cm) max.
Cutout depth	24" (61.0 cm) min.*
Electrical requirements	115 volt, 60 Hz, 15 amp dedicated circuit; 3-wire cord with grounded 3-prong plug attached to product
Maximum amp usage	9.9 amps
Inlet water requirements	1/4" copper tubing inlet waterline; minimum 20 psi; maximum 120 psi
Overall interior dimensions	
Refrigerator	15.3 cu. ft. (434 liters)
Freezer	5.1 cu. ft. (145 liters)
Total capacity	20.4 cu. ft. (579 liters)
Maximum panel weight	Fresh food 45 lbs. (20.4 kg)      Freezer 20 lbs. (9.0 kg)
Approximate shipping weight	500 lbs. (227.3 kg)

**\*Note:** Custom panel models fit flush in 25" (63.5 cm) deep cabinet openings. They can be installed in standard 24" (61.0 cm) deep openings. The door faces and top grille will protrude 3/4" (1.9 cm) into the room.

# Cutout Dimensions (Bottom-Freezer)

## 36" Bottom-Freezer

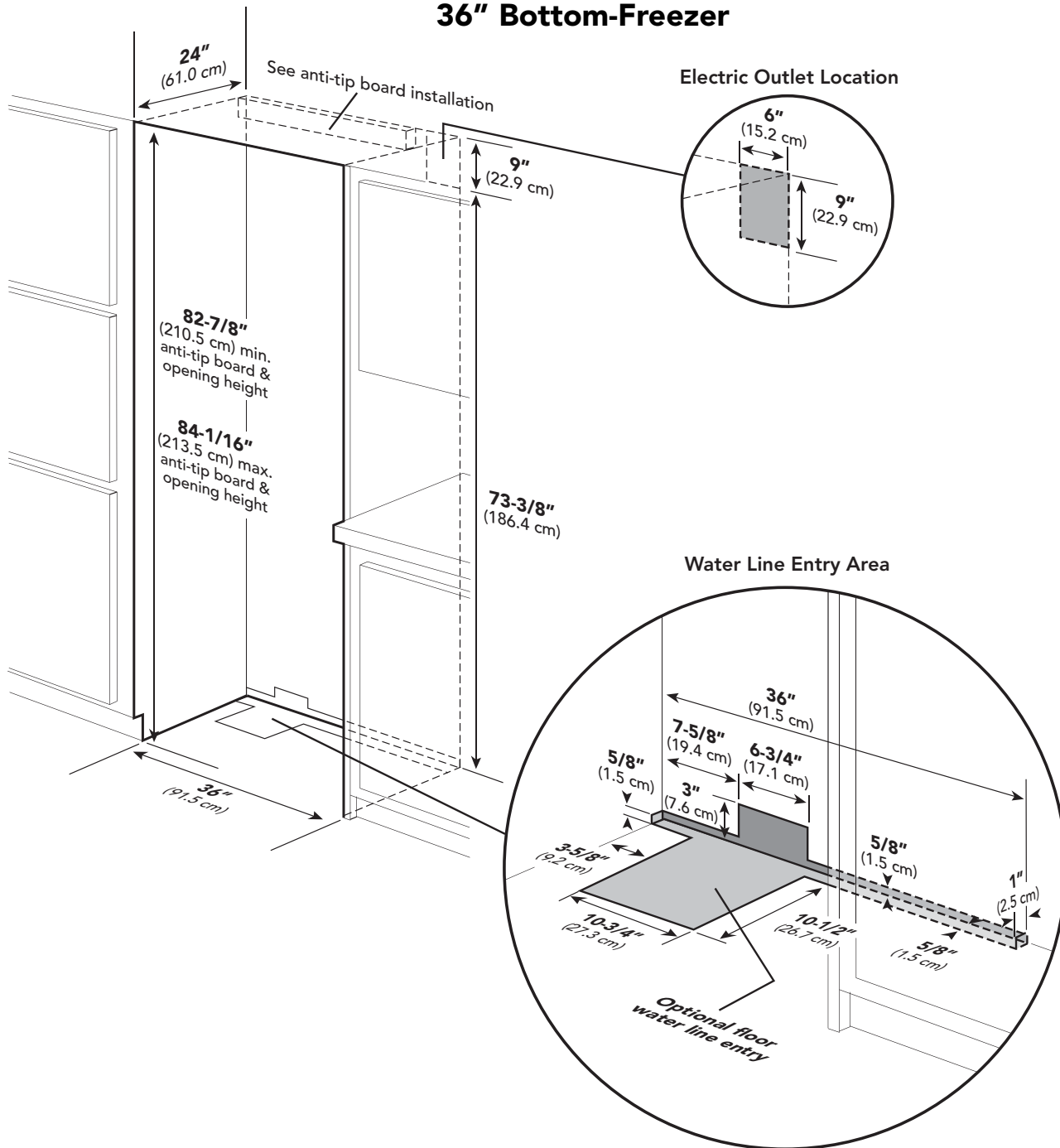

# Anti-Tip Dimensions (Bottom-Freezer)

## 36" Bottom-Freezer

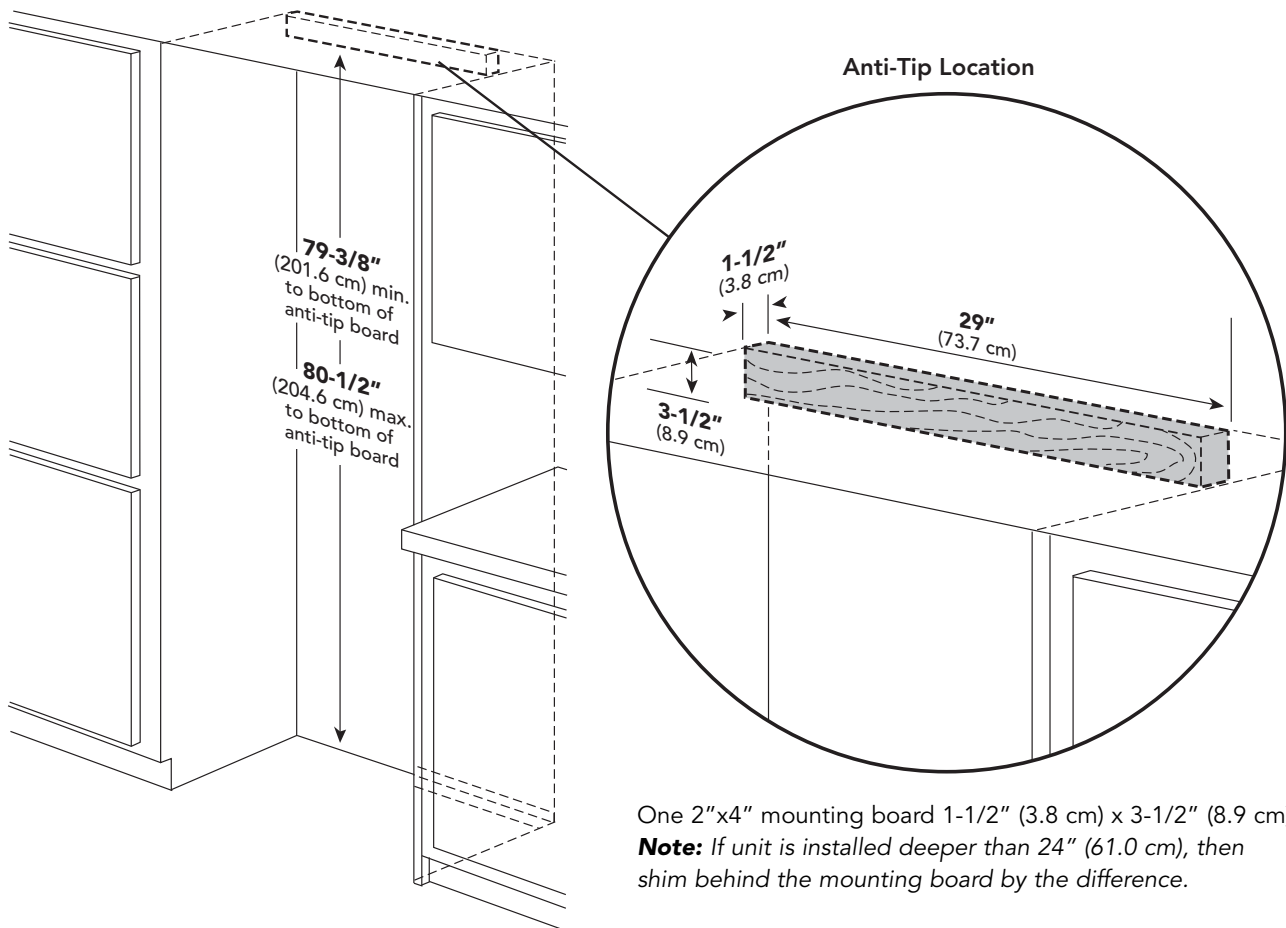

One 2"x4" mounting board 1-1/2" (3.8 cm) x 3-1/2" (8.9 cm)

**Note:** If unit is installed deeper than 24" (61.0 cm), then shim behind the mounting board by the difference.

Bottom of anti-tip board is 3-7/8" (9.8 cm) below the opening height.

**Note:** Top of unit must be placed firmly under anti-tip board.



# Overlay Dimensions (Bottom-Freezer)

## 36" Custom Panels

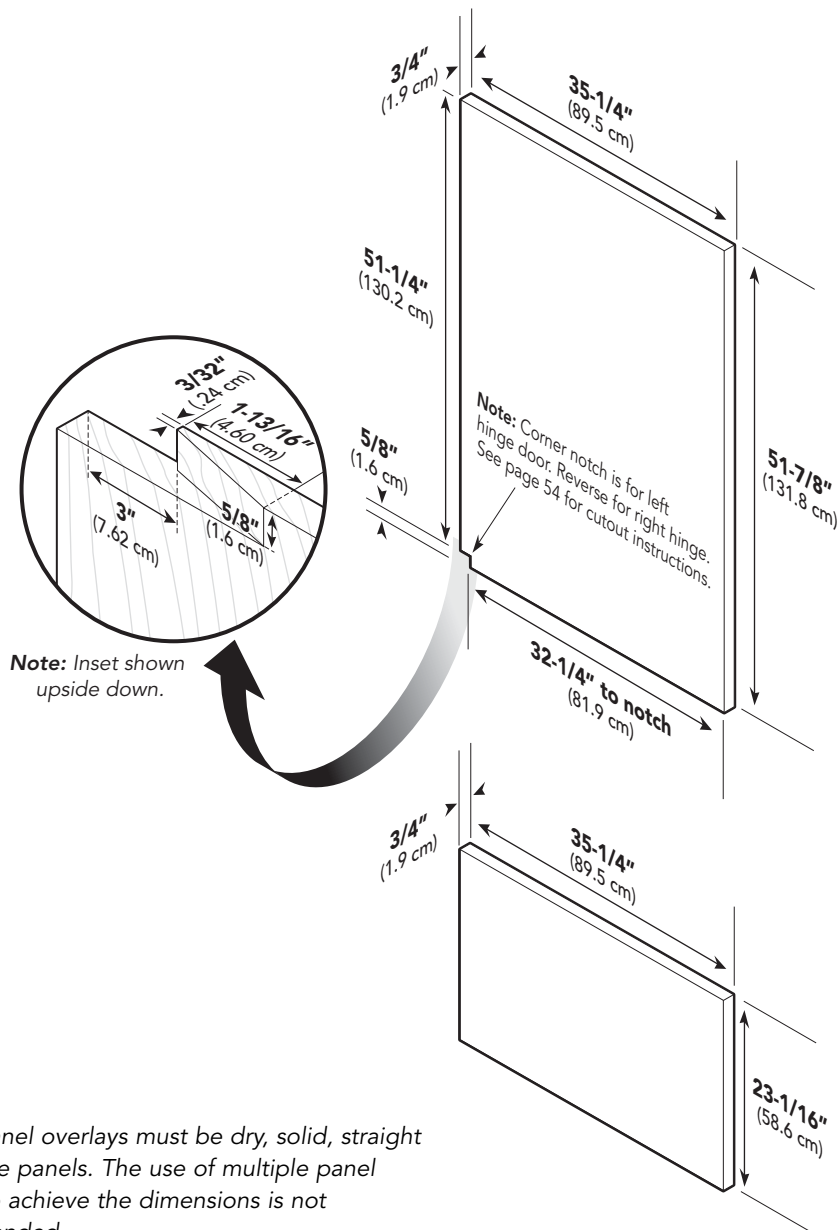

**Note:** Panel overlays must be dry, solid, straight one-piece panels. The use of multiple panel pieces to achieve the dimensions is not recommended.

# Custom Grille Dimensions (Bottom-Freezer)

## 36" Custom Grille

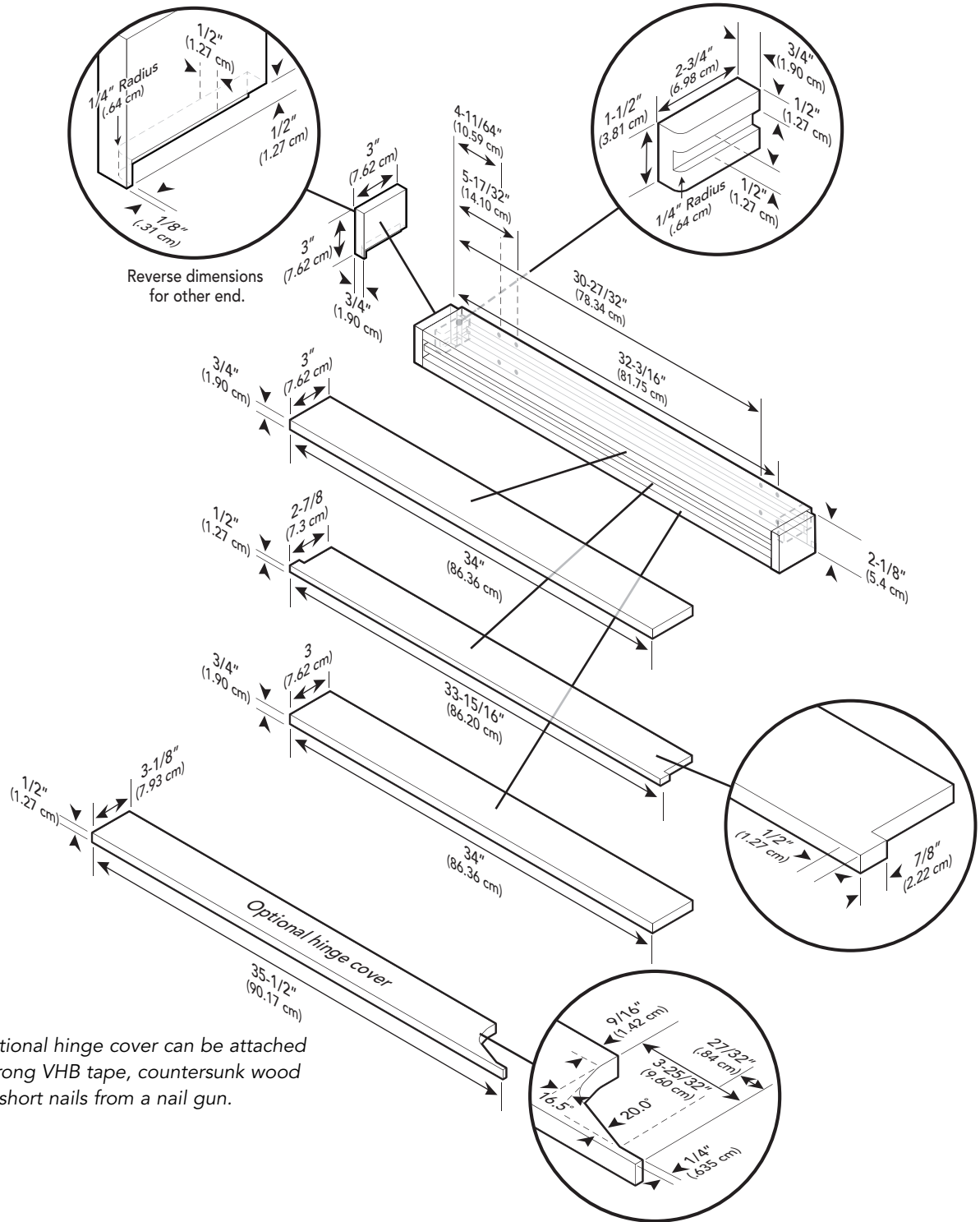



# Cabinet Information

Custom panel models, (with 3/4" [1.9 cm], thick panels and custom handles locally supplied), fit flush in 25" (63.5 cm) deep (countertop depth) cabinet openings with no protrusion into room except custom handles

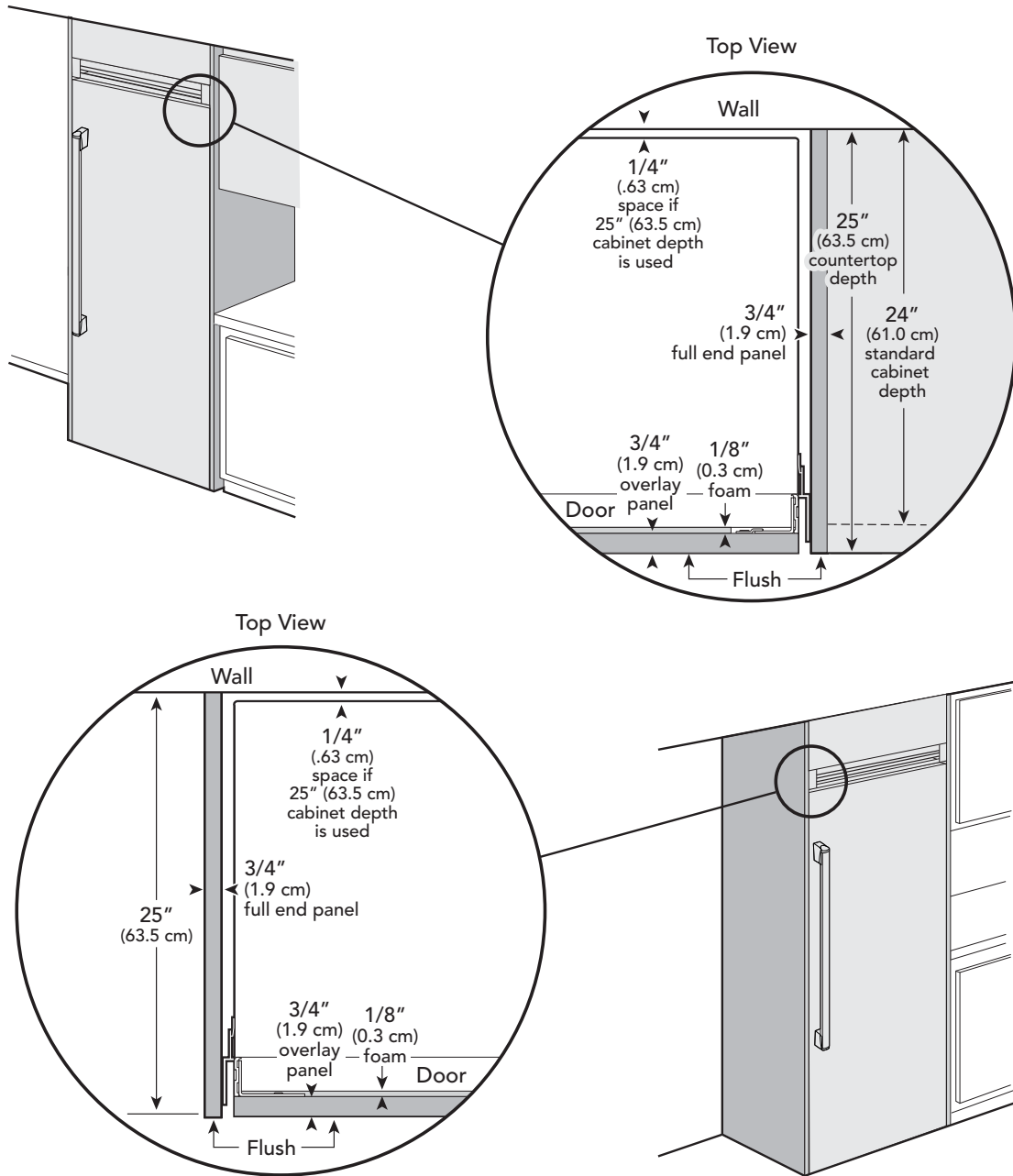

# Custom Side Panel Dimensions

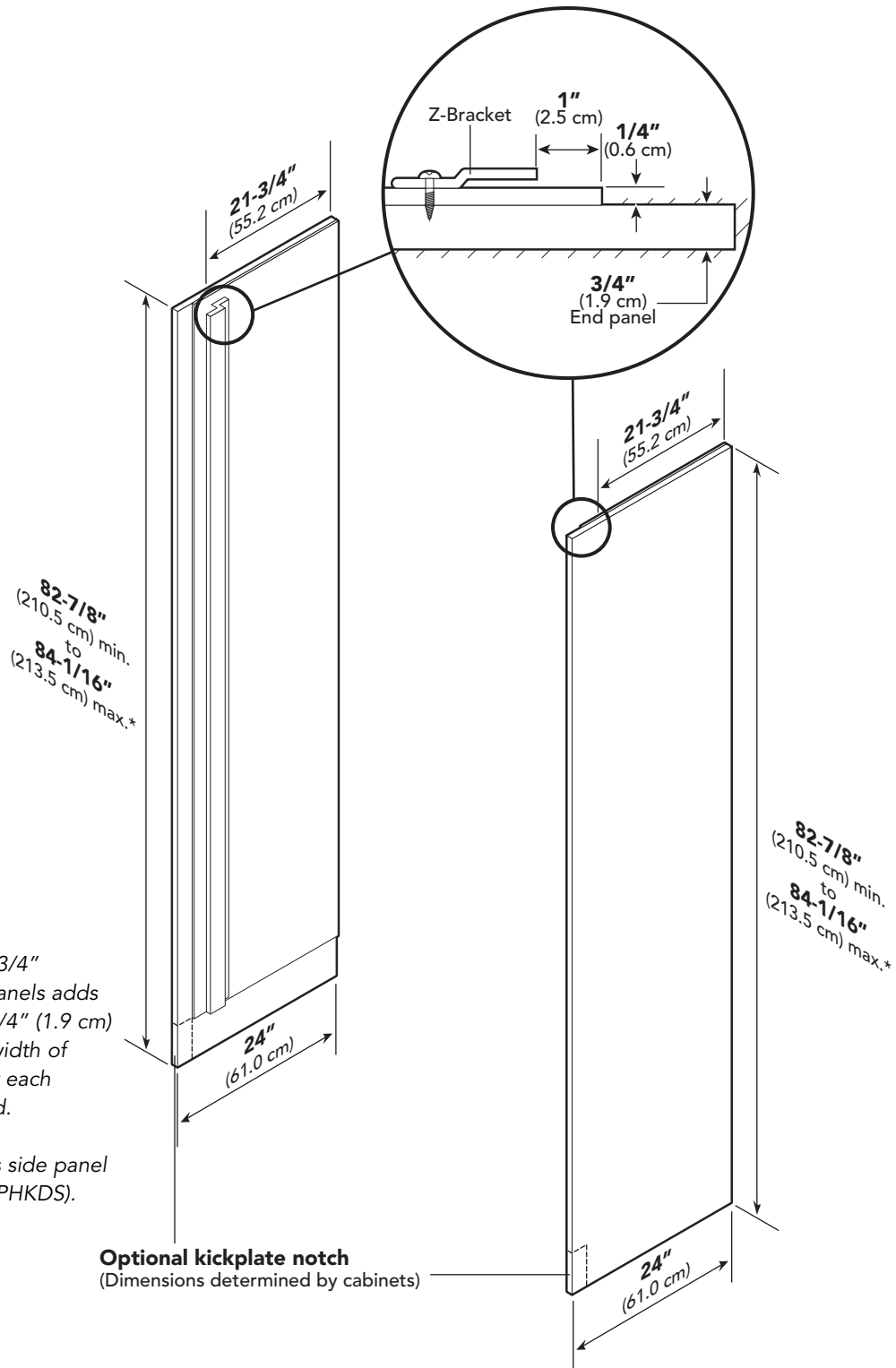

**\*Note:** Depending on how high leveling feet are raised, and cabinet enclosure height.

# Custom Panel General Information

## Custom finishing options

- All installations must allow for the refrigerator and freezer door to open a minimum of 90°.
- For side wall or corner installation, allow for a standard 3" (7.6 cm) cabinet filler to assure door(s) opens 90°.

**Note:** If a custom handle is used, a wider filler may be necessary.

- Panel thickness must not exceed 1" (2.5 cm) on hinge side. Thicker panels will interfere with door swing and clearance.
- Door panels should be installed after the refrigerator has been plugged in for at least 24 hours.

## Custom Door Panel Installation

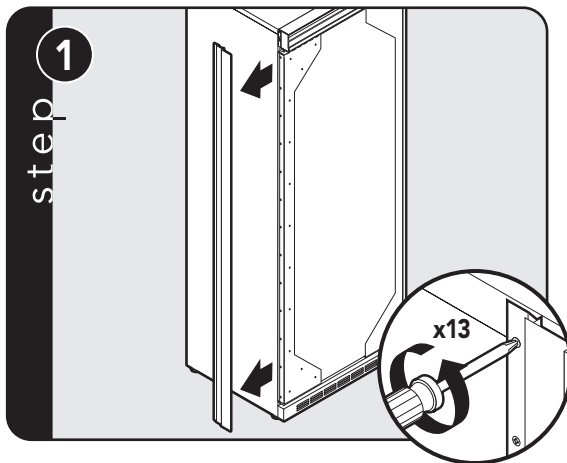

Remove handle side cabinet screws and trim with a phillips screwdriver.

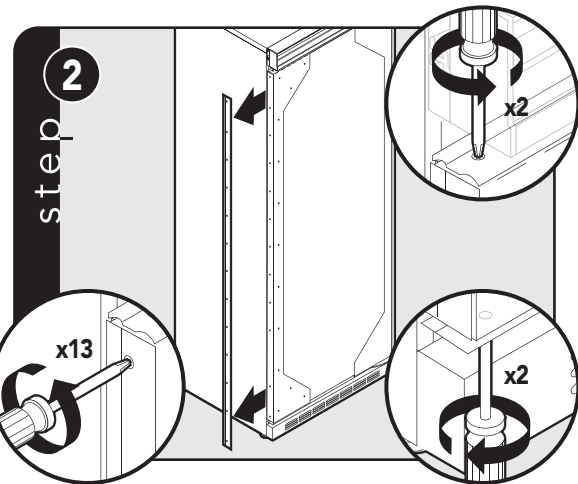

Remove all screws from handle side door trim. Remove two screws from top and bottom door trim. Remove handle side door trim.

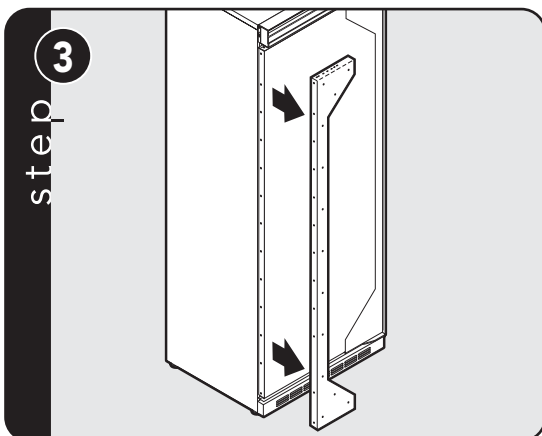

Remove bracket.

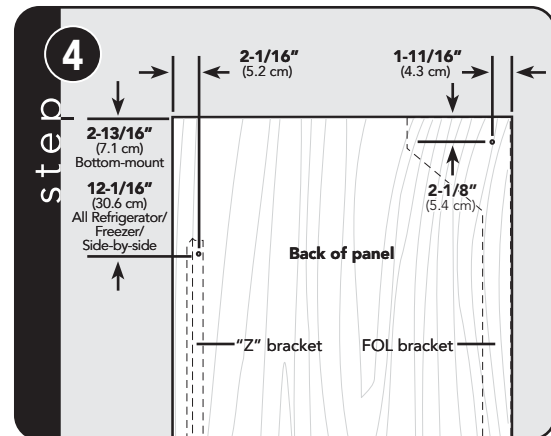

Measure and mark the first hole for each bracket.

## Custom Door Panel Installation (cont.)

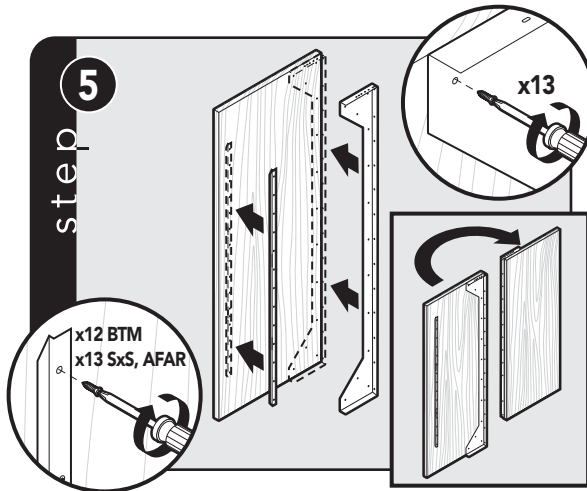

Attach "Z" bracket to the hinge side of custom panel.  
Attach bracket to the handle side of custom panel.

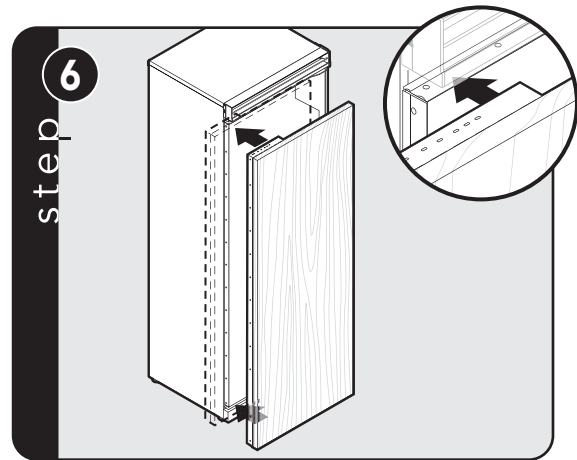

Push custom wood panel onto door.

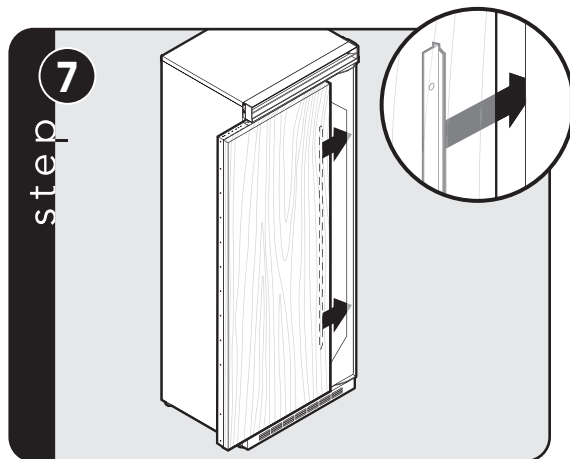

Slide custom wood panel to the hinge side, ensuring  
"Z" bracket engages the door bracket.

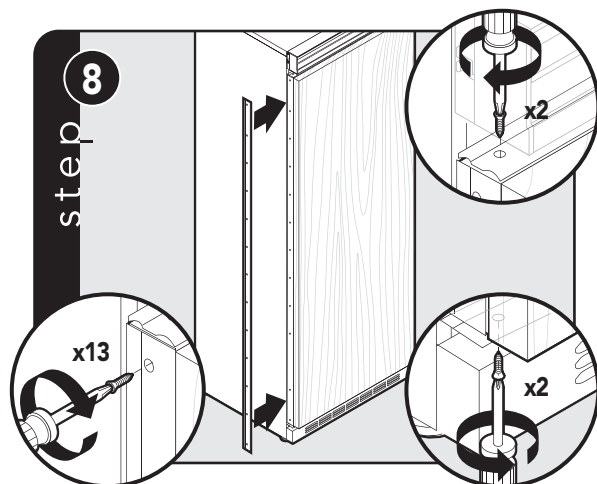

Reinstall handle side door trim  
and door trim screws.

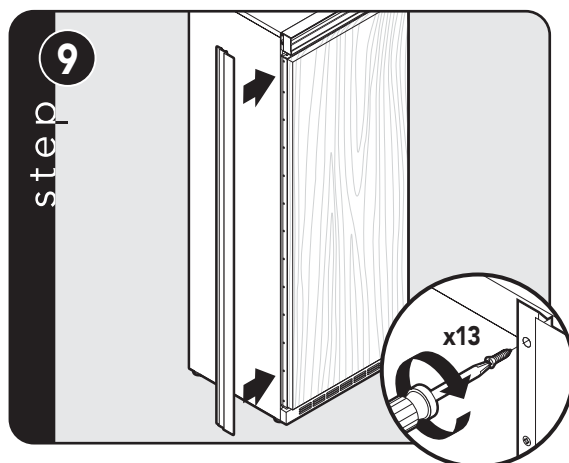

Reinstall cabinet trim and screws.

## Custom Freezer Door Panel Installation (Bottom-Freezer cont.)

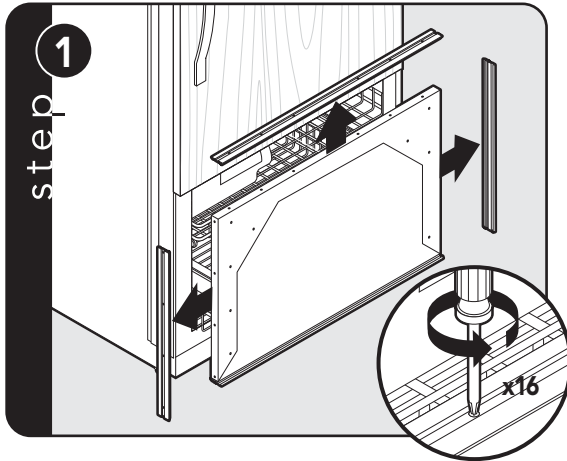

Open freezer door. Remove door trim screws and door trim with a phillips screwdriver.

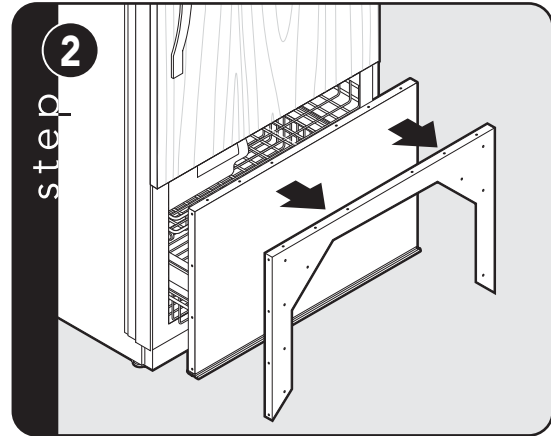

Remove bracket.

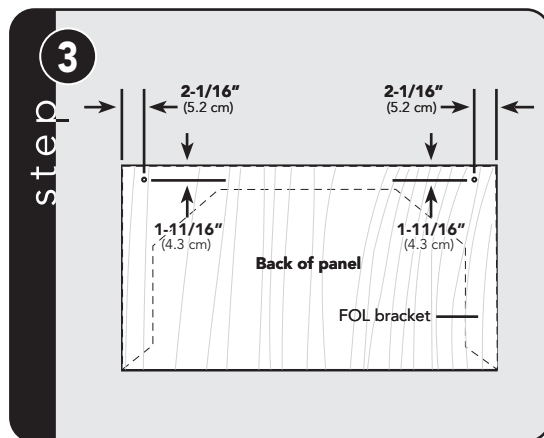

Measure and mark the first hole on each side of the bracket.

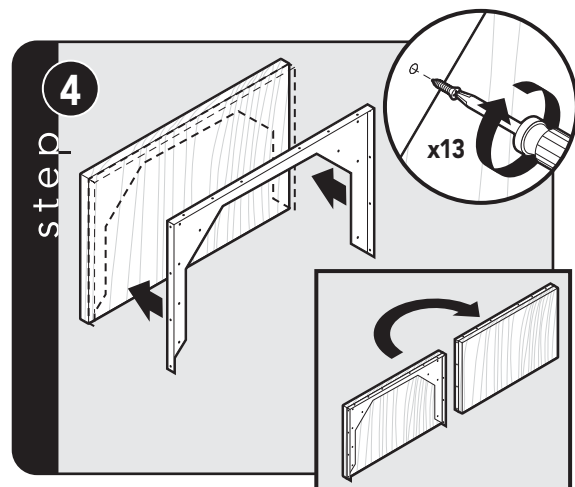

Attach bracket to the custom panel.

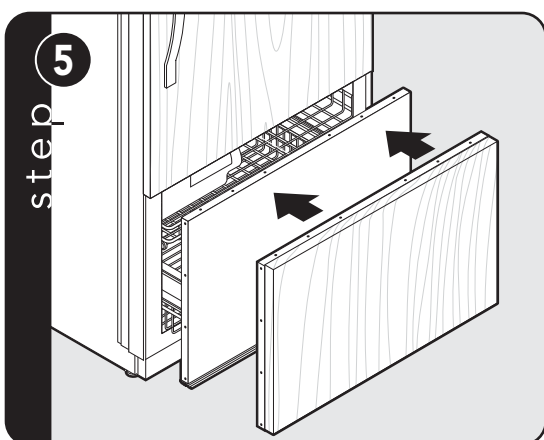

Align and slide custom wood panel onto door.

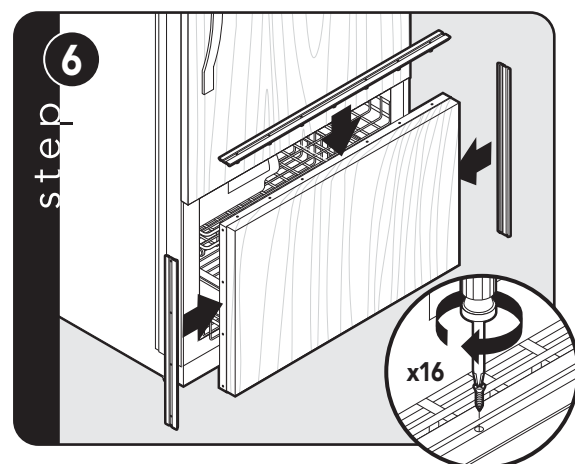

Reinstall door trim and door trim screws.



## Install Door Trim Insert

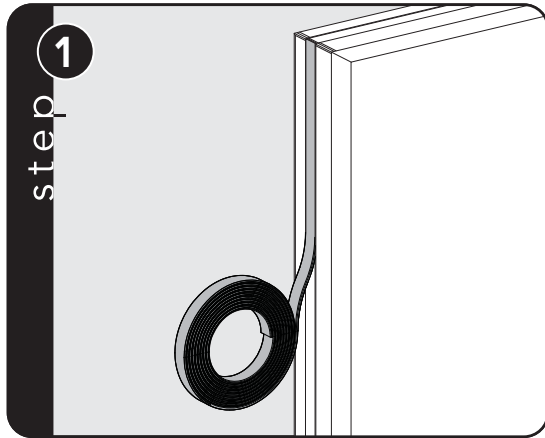

Use the roll of trim insert located in the drawer inside the unit to apply to the door trim.

## Bottom-Freezer Custom Panel Hinge Cutout (if required)

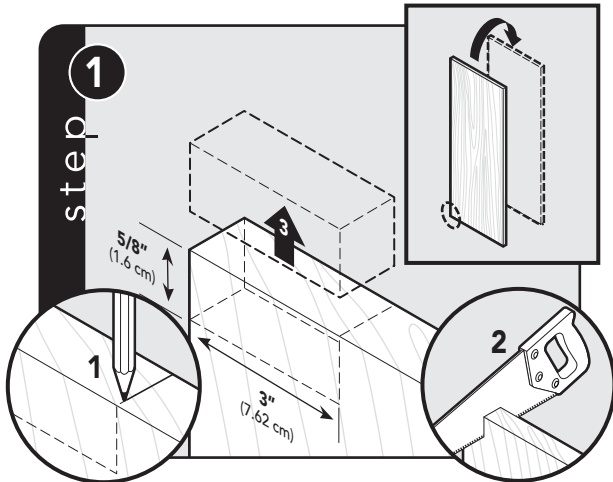

For a left hinge door, cut  $5/8'' \times 3''$  in lower left corner.  
**Note:** Steps show panel upside down and notched for left hinge application. Mirror dimensions for right hinge door.

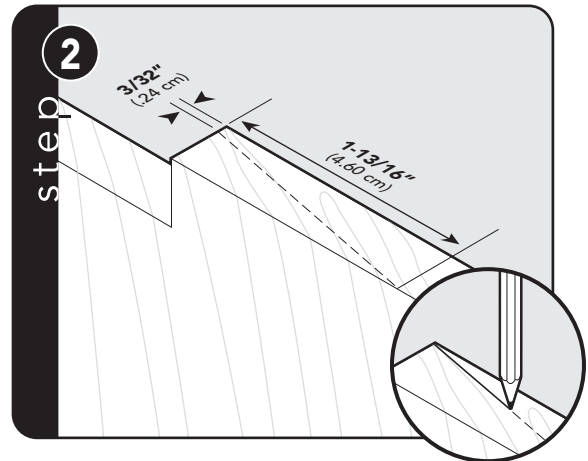

Measure and cut  $2\text{-}1/16''$  (5.2 cm) diagonal in lower left corner.

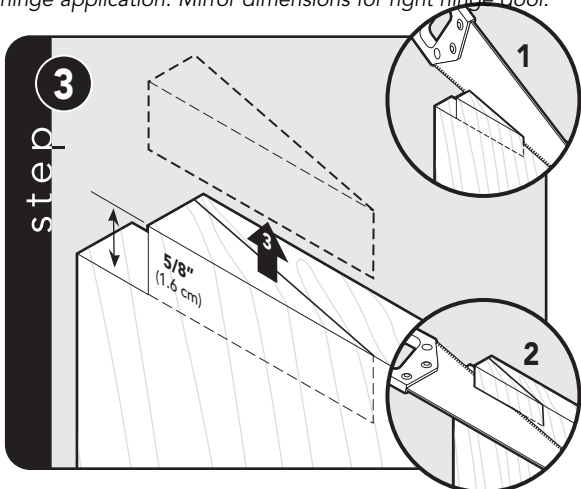

Cut out diagonal in lower left corner.

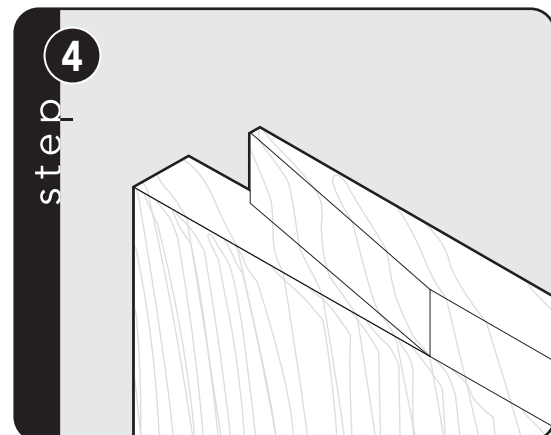

Final view of lower corner.

## Custom Grille Installation

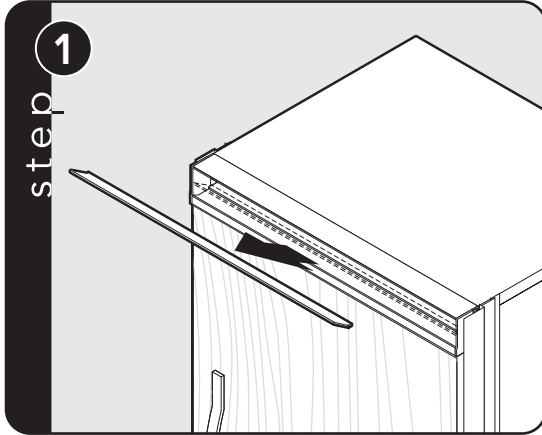

Remove air grille center blade.

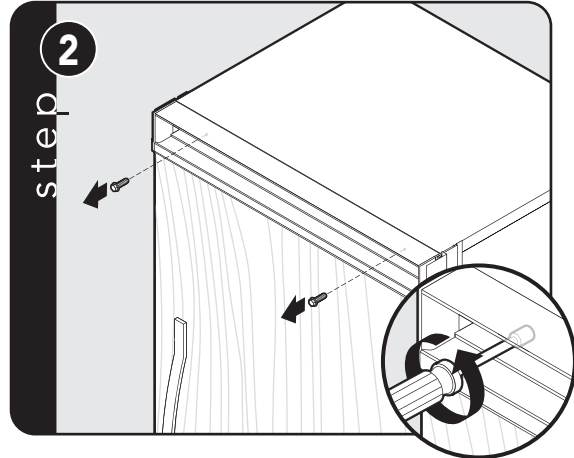

Remove two 1/4" (0.6 cm) screws with a magnetic extended screwdriver at least 8" (20.3 cm) long.

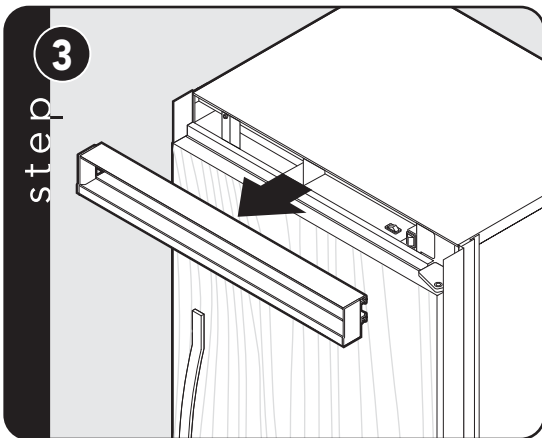

Pull air grille assembly forward.

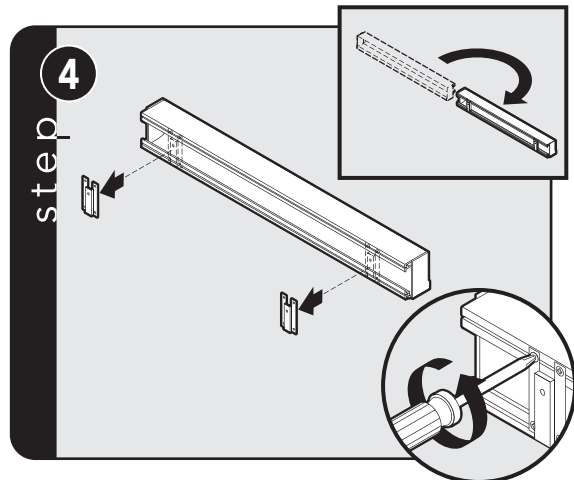

Remove 2 mounting brackets from the grille air assembly.

## Custom Grille Installation (cont.)

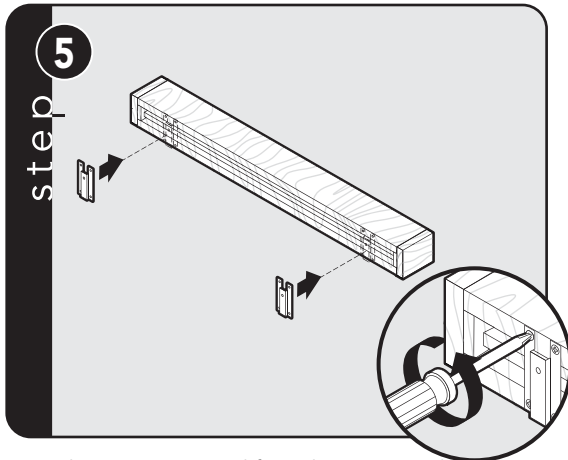

Using eight screws removed from the mounting brackets, attach mounting brackets to the custom wood grille using predrilled pilot holes. (See grille overlay specifications for proper alignment and pilot hole placement.)

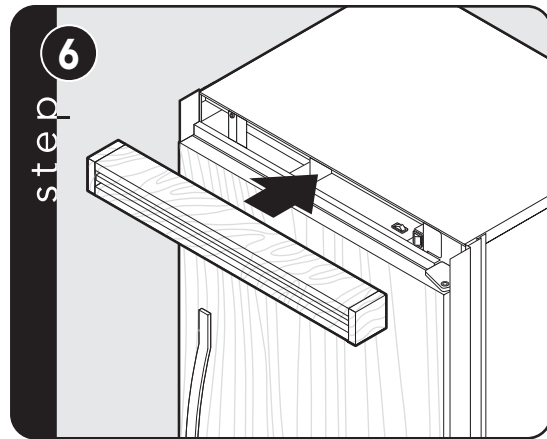

Insert custom air grille assembly.

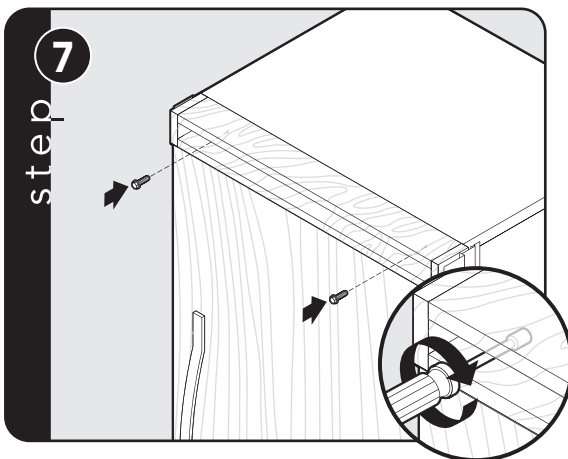

Install two 1/4" (0.6 cm) screws with a magnetic extended screwdriver at least 8" (20.3 cm) long.

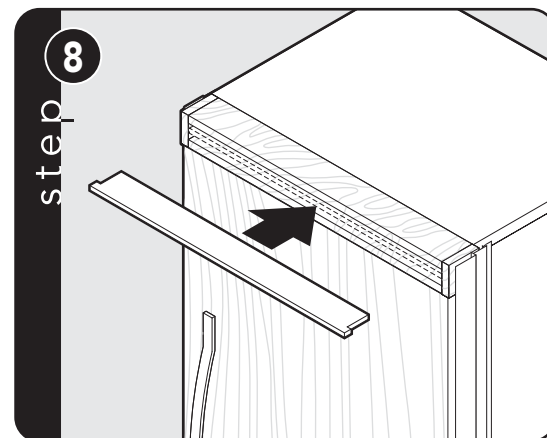

Install custom air grille center blade.

# General Information

## Area Requirements

Verify the following:

- Unit can fit into residence and can be moved around corners and through doorways.
- Floors can support unit's weight plus food weight (approximately 1200 pounds [540 kg] per unit).
- Floors underneath refrigerator are level with surrounding finished floor.
- Rear wall is solid and is able to support two horizontally mounted 2 x 4s (included) bolted to two wall studs. The 2 x 4 board bolt heads must be flush with 2 x 4 to prevent obstruction.
- Remove anything attached to rear or side walls that can obstruct unit installation.
- Cutout dimensions are accurate.
- Electrical outlet is in correct location.
- Water line is in correct location.
- **DO NOT** install a refrigeration unit near a heat source, nor in a location where the surrounding temperature will fall below 60° F (16° C).

## Electrical Requirements

It is the customer's responsibility to:

- Contact a qualified electrical installer.
- Assure that the electrical installation is adequate and in conformance with the National Electrical Code, ANSI/NFPA 70-latest edition or Canadian Electrical Code C22.1-1998 and C22.2 No. 0-M91 (or latest edition), and all local codes and ordinances.

A 115 volt, 60-Hz, 15 amp, fused, electrical supply is required. It is required that a separate circuit serving only this appliance be provided. This appliance is equipped with a power supply cord having a 3-prong grounding plug. To minimize possible shock hazard, the cord must be plugged into a mating 3-prong, grounding-type wall receptacle. **DO NOT use an extension cord.**

If codes permit a separate grounding wire to be used, it is recommended that a qualified electrician determine that the grounding path is adequate.

**DO NOT** ground to a gas line. Check with a qualified electrician if you are not sure if the appliance is properly grounded. **DO NOT** have a fuse in the neutral or grounding circuit.

## Anti-Tip Requirements

The anti-tip boards should be fastened into position prior to moving the unit into the opening.

**Note:** Additional mounting boards may be required if the unit does not touch the back wall of the enclosure. To prevent unit from tipping forward, it must be secured in place with a solid soffit or wood block.

## Water Supply Requirements

### **WARNING**

To avoid serious illness or death, **DO NOT** use unit where water is microbiologically unsafe or of unknown quality, without adequate disinfection before or after the system. Systems certified for cyst reduction may be used on disinfected water that may contain filterable cysts. The contaminants or other substances removed or reduced by this water treatment system are not necessarily in your water.

**Use only 1/4" (6 mm) copper tubing for water line. DO NOT install copper tubing in area where temperatures drop below 35° F (1.7° C). Before attaching copper tubing to the unit, flush at least 2 quarts (1.9 L) of water through the copper tubing and into a bucket to remove any particles in the water line.**

- **Viking Range, LLC is not responsible for property damage due to improper installation or water connection.**
- Connect 1/4" (6 mm) flexible copper tubing to household plumbing in compliance with local codes and ordinances.
- Length of copper tubing must reach from water supply connection to the unit connection with an additional length to facilitate moving the unit out of enclosure for cleaning or service. Tubing should be soft instead of rigid and ends should be free of burrs.
- Copper tubing route must be above 35° F (1.7° C) to prevent water line from freezing.
- **DO NOT use plastic water lines from the household plumbing to the water inlet valve connection on the refrigeration unit.**

# General Information

- **DO NOT** use the self-piercing feature of a saddle valve. The hole made by the piercing lance is too small for the water flow rate required by the ice maker.
- If saddle valve is not used, place a separate shut-off valve in an easily accessible location between water supply and the unit. **DO NOT** install shut-off valve behind the unit.
- The installation of appliances with a reverse osmosis system is acceptable **as long as the water pressure remains within the allowable PSI as stated below.** It is important to note that with many reverse osmosis systems, the pressure range starts off high, but then it decreases as the water level of the reverse osmosis storage area drops. This must be considered when checking the water pressure coming into the unit.
- Connect a vertical or horizontal 1/2" (1.2 cm) to 1-1/4" (3.2 cm) COLD water line near water area.
- Run water line through the floor, back, or side wall. Tubing should lay flat on floor underneath the unit. Clamp tubing to wall or floor.
- Water pressure must be greater than 20 psi and less than 120 psi on non-dispensers and greater than 35 psi and less than 120 psi on dispensers.
- Most of the unit's weight is at the top. Extra care is needed when moving the unit to prevent tipping.
- **DO NOT** remove protective film until unit is in operating position.
- All four leveling legs must make contact with the floor to support and stabilize the full weight.
- **DO NOT** drop unit.
- Remove exterior shipping materials prior to moving unit into home.
- Use two or more people to move and install unit. Failure to follow this instruction can result in back or other injury.
- To avoid personal injury, wear gloves when performing any installation procedure and wear eye protection when cutting metal straps.

## Tip Over Hazard

Appliance is top heavy and tips easily when not completely installed. Keep doors closed until appliance is completely installed and secured per installation instructions. Use two or more people to move and install the appliance. Failure to do so can result in death or serious injury.

## Unpacking unit

1. Remove top and bottom strap.
2. Remove top cap.
3. Cut rear of carton approximately 1/4" (0.6 cm) to 1" (2.5 cm) from right corner with a utility knife extended 1/4" (0.6 cm).
4. Remove carton and exterior packaging. Save cardboard shipping material to protect floor surface when installing unit. Remove anti-tip board, kickplate and door trim pieces (DF models) from rear of unit.

## Moving Unit

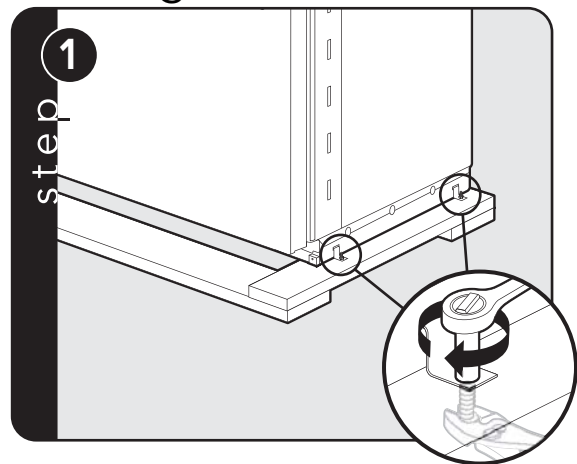

Remove shipping brackets from skid by removing four bolts (two on each side) with a 1/2" deep-well socket wrench and a pair of pliers.

**Note:** Tilting unit is not required to remove shipping brackets.

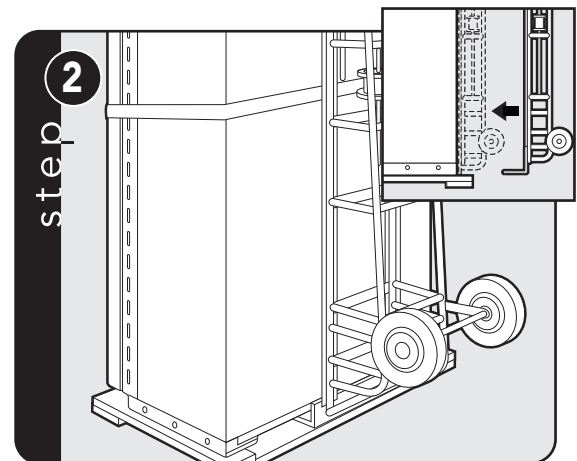

Slip cart between unit and skid. Remove unit from skid.

**Note:** Use excess packaging to protect decorative trim; also, verify that leveling legs are up (0" adjustment).

# Installation

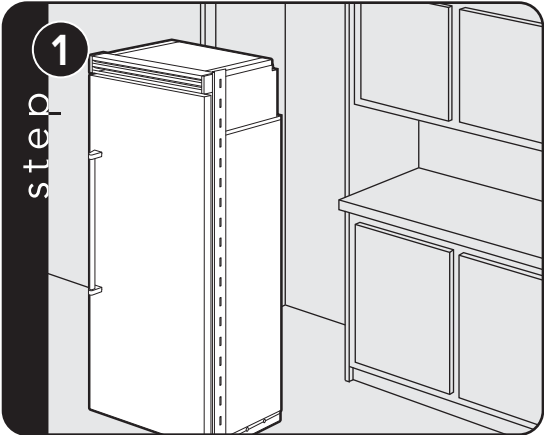

Place unit in front of cutout.

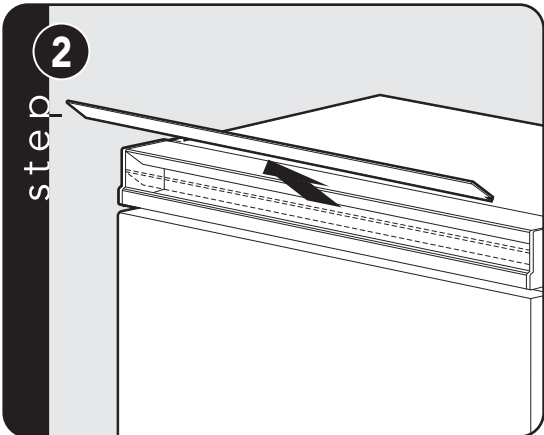

Pull the center grille louver up at an angle and pull out.

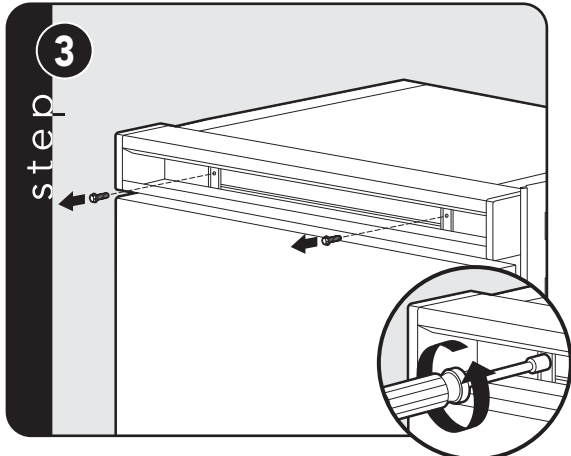

Using an 8" (20.3 cm) magnetic nut driver, remove the two 1/4" (0.6 cm) screws.

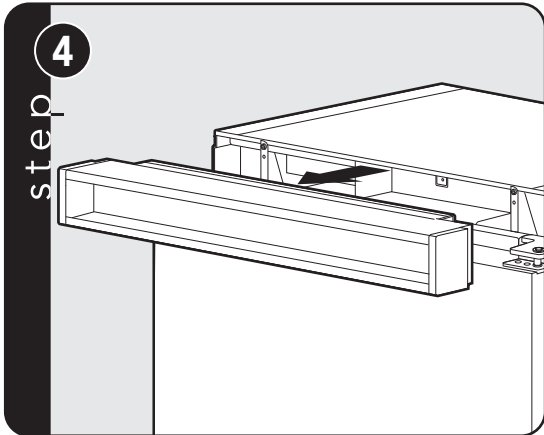

Remove grille assembly.

## Hinge Adjustment

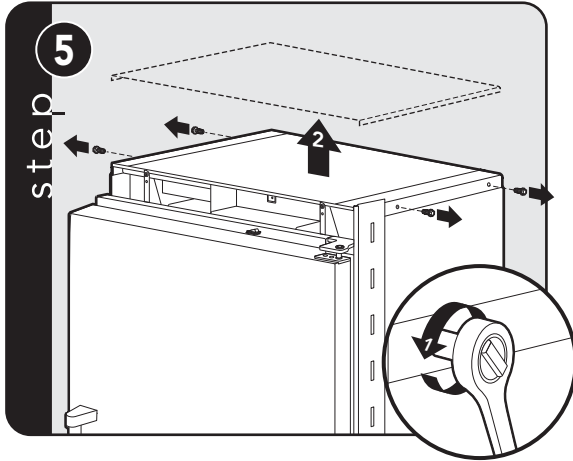

Remove four side screws and remove unit top.

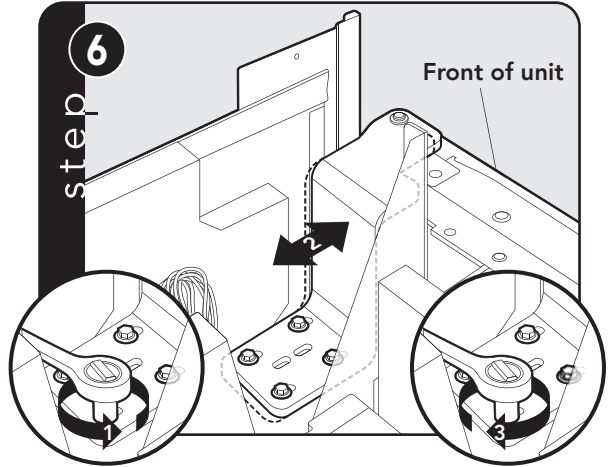

Loosen the four hinge screws. Adjust door.  
Retighten four hinge screws.

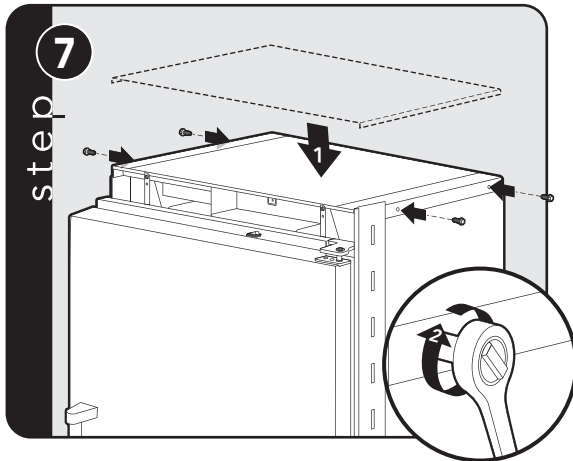

Replace unit top and four side screws.

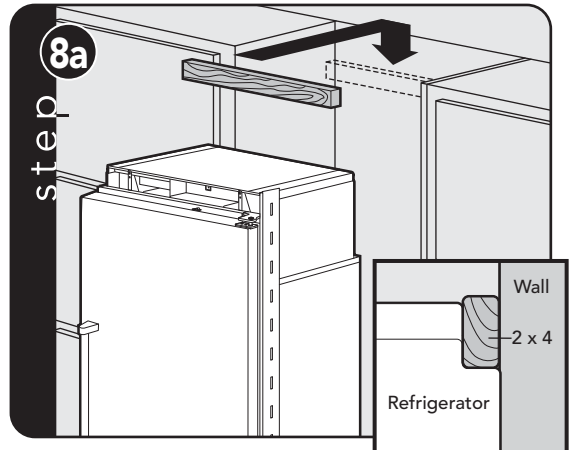

Attach one 2 x 4 to wall stud (refer to dimensions page for exact location).

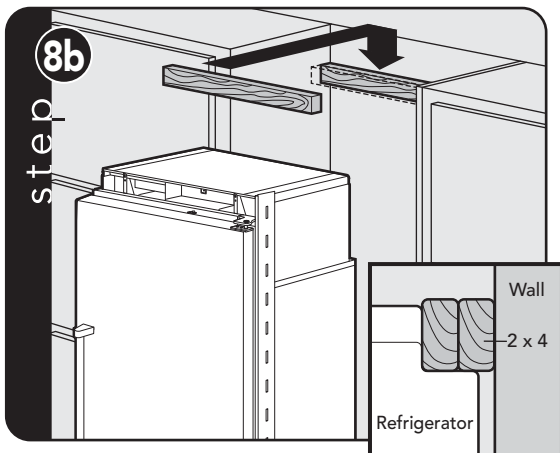

If needed, depending on cabinet and depth, attach second 2 x 4 to first 2 x 4.

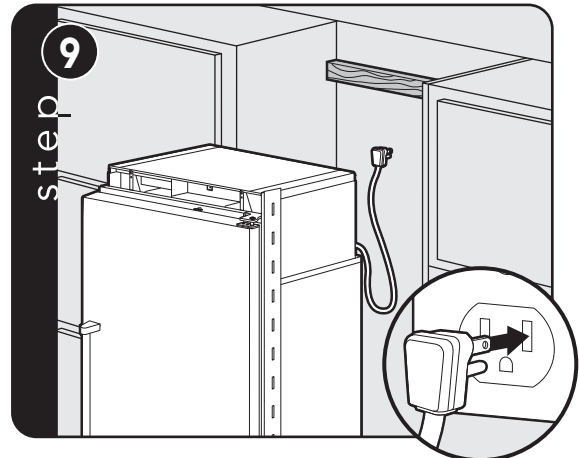

Plug in power cord to verify operation.

**Note:** Make sure power switch is in the "On" position.

## Installation (cont.)

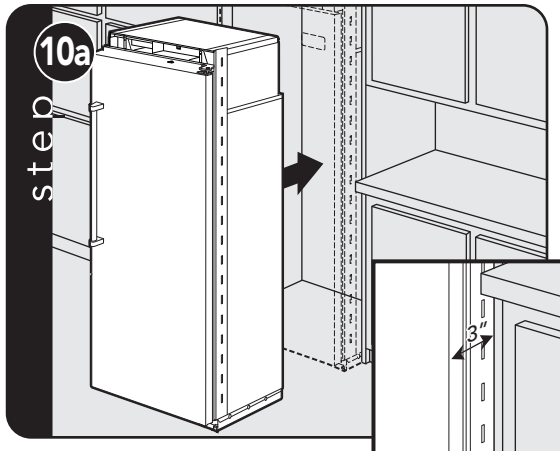

Place unit within 3" of being flush with cabinets. **Note:** To avoid cabinet damage, place cardboard between cabinets and unit. When moving unit, **DO NOT** crimp, kink or crush water supply line.

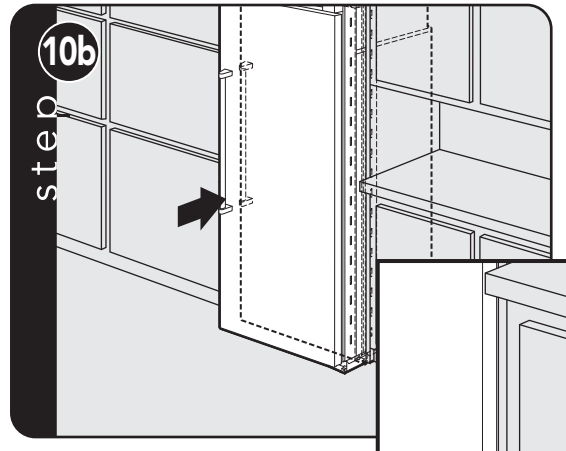

Carefully move unit until semi flush with cabinet (depending on unit).

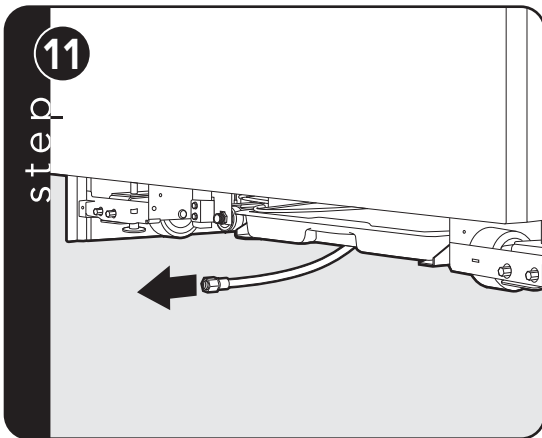

Pull supply tubing forward under unit. **Note:** **DO NOT** use plastic water lines.

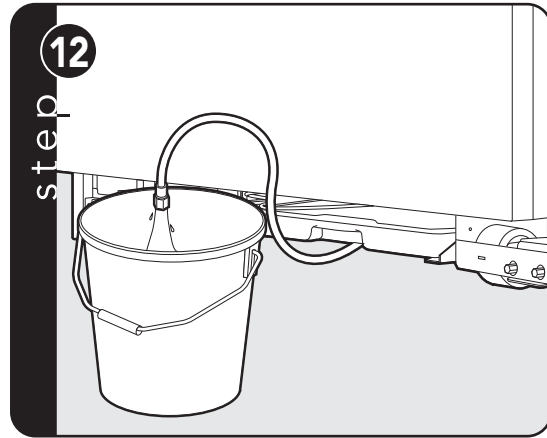

Flush water line by running two quarts of water into a bucket. Turn water off

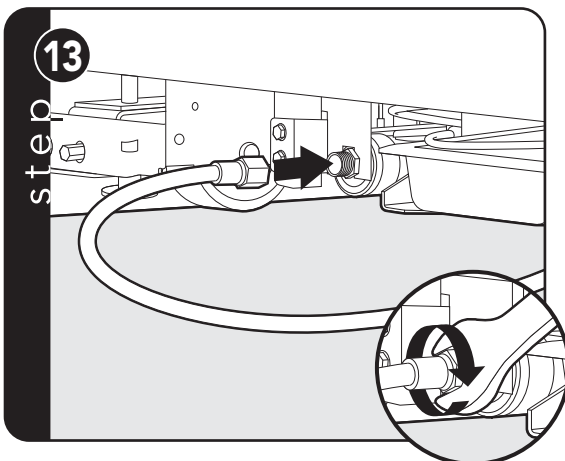

Connect supply tube to water valve using a 1/2" (1.3 cm) wrench. **Note:** **DO NOT** overtighten.

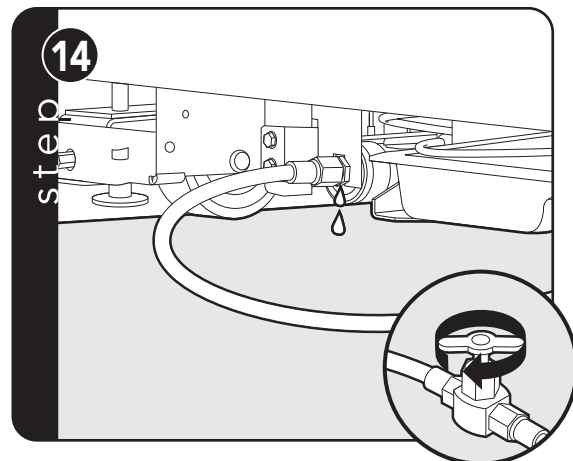

Turn on water supply and check for leaks.



## Hinge Adjustment (cont.)

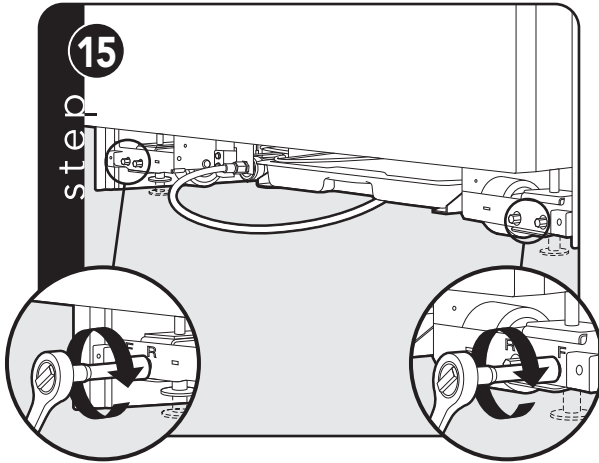

Lift unit off rollers to desired height and level unit using a 5/16" head wrench.

**Note: DO NOT** use an electric device.  
Overtightening can cause damage.

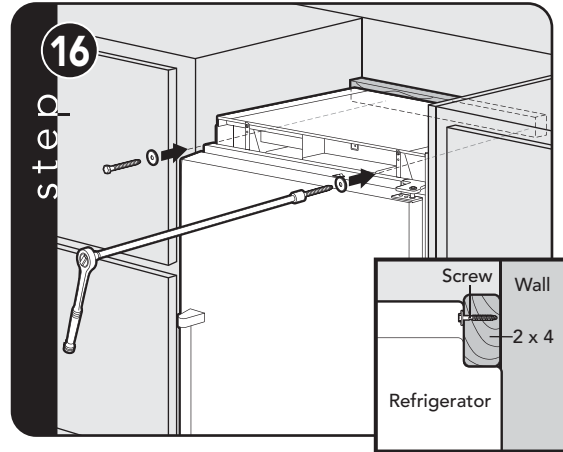

Attach positive secure self-tapping bolts to 2 x 4 using a 22" (55.6 cm) extension.

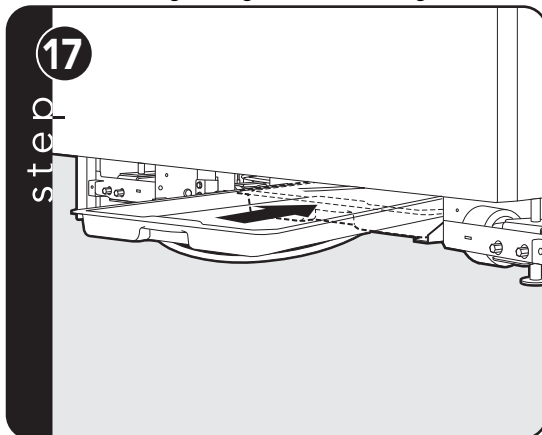

Verify that drain pan is installed and aligned.

## Kickplate Installation

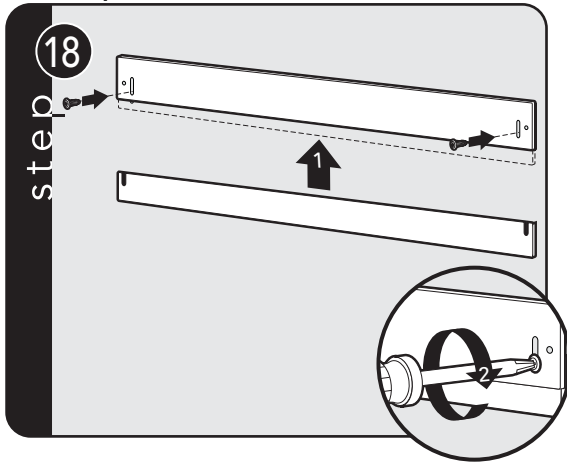

Align holes on both ends of louvered panels and insert screws.

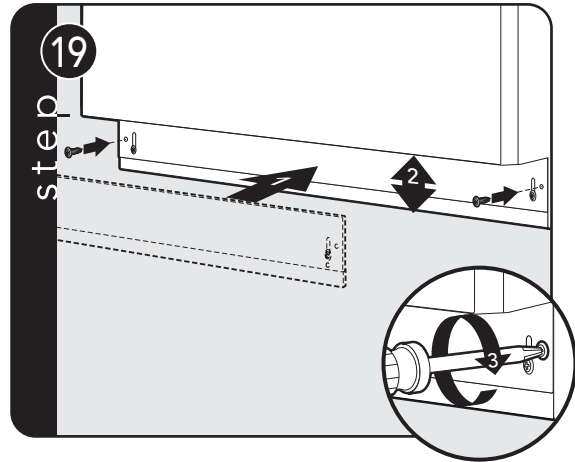

Using a phillips screwdriver, attach the kickplate to the unit and adjust to desired height.

## Door Stop Adjustment (Bottom-Freezer)

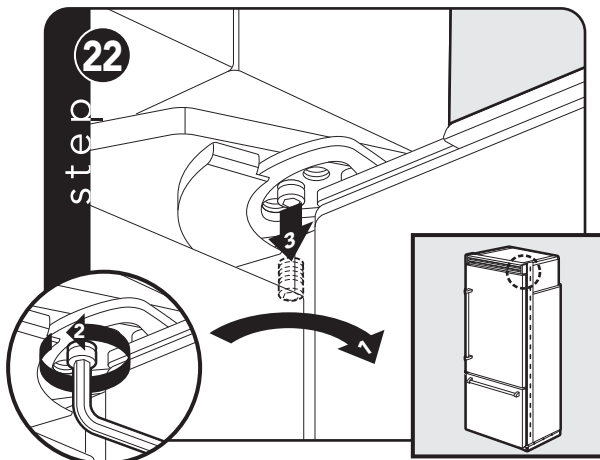

Open refrigerator door so door stop and shoulder screw are accessible.

**Note:** Shoulder screw should be in 110° door opening position.

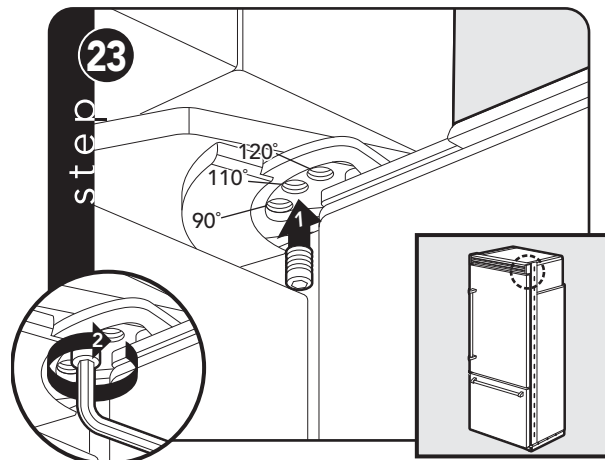

Remove shoulder screw and place in 90° or 120° position.

# Water Filter System Specification and Performance Data Sheet

This system has been tested according to NSF/ANSI 42/53 for reduction of the substances listed below. The concentration of the indicated substances in water entering the system was reduced to a concentration of less than or equal to the permissible limit for water leaving the system, as specified in NSF/ANSI 42/53.\* (100% safety factors built-in for unmetered usage for health claims only.)

Contaminant Reduction	Average Influent	NSF Specified Challenge Concentration	Avg % Reduction	Average Product Water Concentration	Max Permissible Product Water Concentration	NSF Reduction Requirements	NSF Test Report
Chlorine Taste and Odor	2.0 mg/L	2.0 mg/L $\pm$ 10%	97.5%	0.05 mg/L	N/A	$\geq$ 50%	J-00056501
Nominal Particulate Class I, $\geq$ 0.5 to < 1.0 $\mu$ m	13,666,667 pts/mL	At least 10,000 particles/mL	98.9%	143,333 pts/mL	N/A	$\geq$ 85%	J-00056506
Asbestos	96 MF/L	10 <sup>7</sup> to 10 <sup>8</sup> fibers/L; fibers greater than 10 $\mu$ m in length	>99%	<1 MF/L	N/A	$\geq$ 99%	J-00056511
Atrazine	0.010 mg/L	0.009 mg/L $\pm$ 10%	89.3%	0.001 mg/L	0.003 mg/L	N/A	J-00056512
Cyst*	122,500 cysts/L	Minimum 50,000 cysts/L	99.99%	1 cyst/L	N/A	$\geq$ 99.95%	J-00056513
Lead @ pH 6.5	0.153 mg/L	0.15 mg/L $\pm$ 10%	99.3%	0.001 mg/L	0.010 mg/L	N/A	J-00056515
Lead @ pH 8.5	0.150 mg/L	0.15 mg/L $\pm$ 10%	99.3%	0.001 mg/L	0.010 mg/L	N/A	J-00058784
Lindane	0.002 mg/L	0.002 mg/L $\pm$ 10%	97.8%	0.00004 mg/L	0.0002 mg/L	N/A	J-00058969
Mercury @ pH 6.5	0.006 mg/L	0.006 mg/L $\pm$ 10%	95.0%	0.0003 mg/L	0.002 mg/L	N/A	J-00058785
Mercury @ pH 8.5	0.006 mg/L	0.006 mg/L $\pm$ 10%	88%	0.0007 mg/L	0.002 mg/L	N/A	J-00058783
Toxaphene	0.015 mg/L	0.015 mg/L $\pm$ 10%	93.2%	0.001 mg/L	0.003 mg/L	N/A	J-00056531
Turbidity	10.8 NTU	11 $\pm$ 1 NTU	98.7%	0.153 NTU	0.5 NTU	N/A	J-00058972

\*Based on the use of Cryptosporidium parvum oocysts

## Operating Specifications

Capacity:	Certified for up to 750 gallons (2,838 L); up to nine months
Pressure Requirement:	20 - 120 psi (1.4 - 8.2 bar)
Temperature:	33-100°F (0.6 - 37.8°C)
Flow rate:	0.78 gpm (2.9 l/min.)

Check for compliance with the state and local laws and regulations.

**Note:** While the testing was performed under standard laboratory conditions, actual performance may vary. Must be installed and operated in accordance with manufacturer's recommended procedures and guidelines. Installation instructions, parts and service availability, and standard warranty are included with the product when shipped. This drinking water system must be maintained according to manufacturer's instruction, including replacement of filter cartridges.

Manufactured by: 3M Purification Inc.  
400 Research Parkway  
Meriden, CT 06770

System tested and certified by NSF International against Standard 42 for the reduction of chlorine taste and odor, particulate Class I and Standard 53 for the reduction of Lead, Lindane, Atrazine, Mercury, Toxaphene, Cyst, Turbidity, and Abestos.



## Final Installation

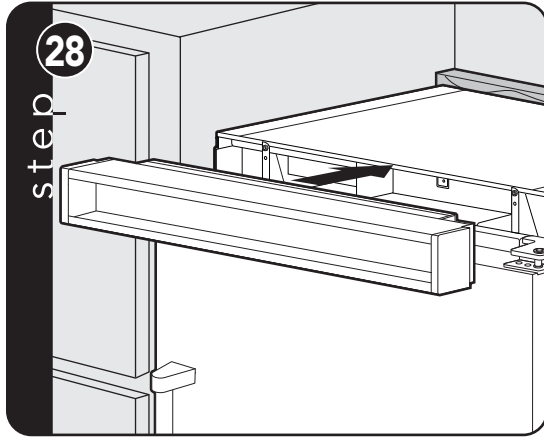

Replace top air grille.

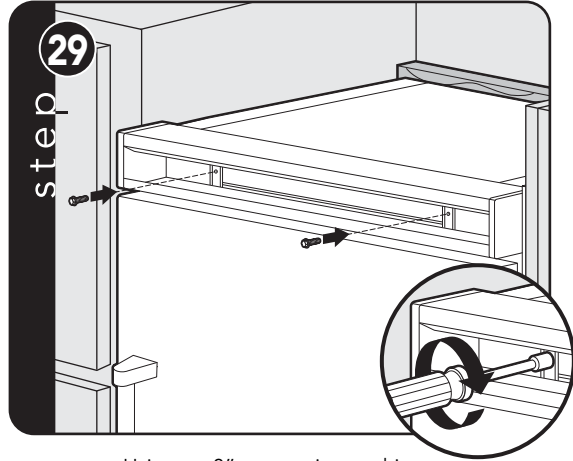

Using an 8" magnetic nut driver, replace the two 1/4" screws.

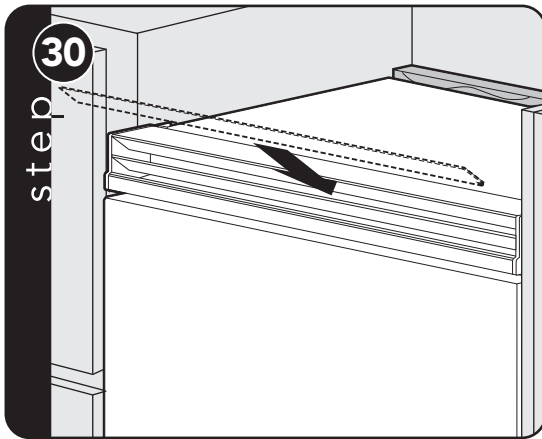

Replace the center grille louver.

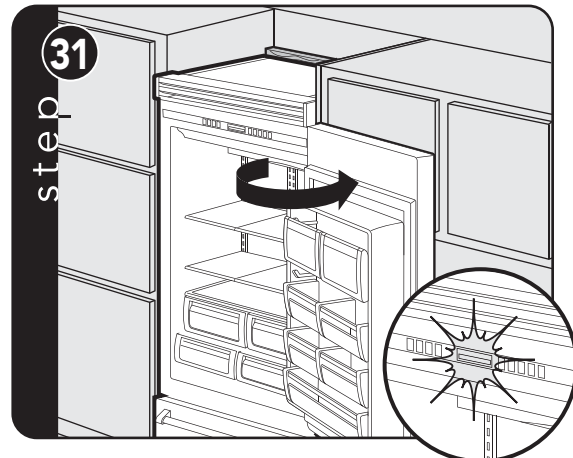

Open door. The display should flash.

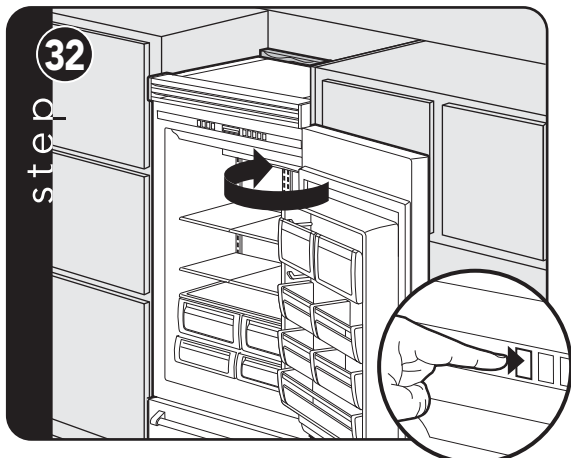

Press "ACTIVATE CONTROLS" pad and close door.

**Note:** There is a 6 minute delay before the unit starts.

# Performance Checklist



- Verify cabinet size.
- Verify electrical supply and water supply (if applicable).
- Install anti-tip device(s) and verify unit is secure.
- Position unit in cutout, level at desired height and secure unit.
- Plug-in unit and verify operation.
- Connect water supply (if applicable).
  - Verify icemaker fill tube is properly inserted.
  - Verify icemaker bail arm is down.
  - Verify dispenser operation (if applicable).
- Align/square door(s).
- Verify drain pan is properly installed and there are no leaks on water connection.
- Install kickplate.
- Remove internal packaging and labels and wipe unit down.

## Installer's information:

Installer's name: \_\_\_\_\_

Installer's company: \_\_\_\_\_

Date: \_\_\_\_\_

# Verify Operations

## Control Panels

### Bottom-Freezer

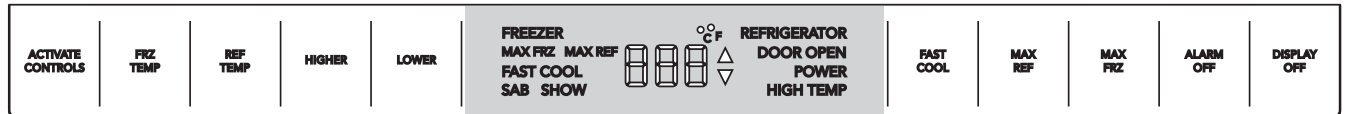

1. Press "Activate Controls" pad.

2. Verify unit is not in Sabbath Mode.

**If in Sabbath Mode:**

A. The Sabbath Mode will disable the interior lights, display (except SAB indicator, temperature and compartment indicator) and alarm.

**To exit the Sabbath Mode:**

B. Press and hold "Activate Controls" and then "Display Off" for 3 seconds. (The control will beep three times to alert the user the Sabbath Mode has been exited.)

3. Verify unit is not in Showroom Mode.

**If in Showroom Mode:**

A. The Showroom Mode will disable the refrigerator system but all other functions are normal. These include lights and control. (If the refrigerator is in Showroom Mode, SHOW will be lit.)

**To exit Showroom Mode:**

B. Press and hold "Activate Controls"; while holding, press and hold "Higher" and "Alarm Off" together. (The control will beep three times to alert the user that Showroom Mode has been exited.)

4. Press "Activate Controls" then press and hold "Lower"; while holding, press and hold "Display Off" and hold until beeps (force start compressor).

5. All models need to be set at 38° F and 0° F for the Refrigerator and Freezer respectfully - factory setting.

# Service & Registration

If service is required, call your authorized service agency.

Have the following information readily available.

- Model number
- Serial number
- Date purchased
- Name of dealer from whom purchased

Clearly describe the problem that you are having. If you are unable to obtain the name of an authorized service agency, or if you continue to have service problems, contact Viking Range, LLC at 1-888-(845-4641), or write to:

**VIKING RANGE, LLC  
PREFERRED SERVICE  
111 Front Street  
Greenwood, Mississippi 38930 USA**

Record the following information indicated below. You will need it if service is ever required.

The serial number and model number for your appliance are located on the identification plate mounted on the bottom left side of the door opening.

Model No. \_\_\_\_\_

Serial No. \_\_\_\_\_

Date of Purchase \_\_\_\_\_

Date Installed \_\_\_\_\_

Dealer's Name \_\_\_\_\_

Address \_\_\_\_\_

If service requires installation of parts, use only authorized parts to insure protection under the warranty.

**Keep this manual for future reference.**

Viking Range, LLC  
111 Front Street  
Greenwood, Mississippi 38930 USA  
(662) 455-1200

For product information,  
call 1-888-(845-4641)  
or visit our web site at [brigade.ca](http://brigade.ca)

