

VentA Hood® WALL MOUNT RANGE HOOD SPECIFICATIONS

ZTH Equipped with halogen lighting. These models not available with heat lamps. Only available in stainless steel. Shown with optional duct cover (sold separately). Optional duct covers available in standard and custom sizes (sold separately). Fixed pot rails included.

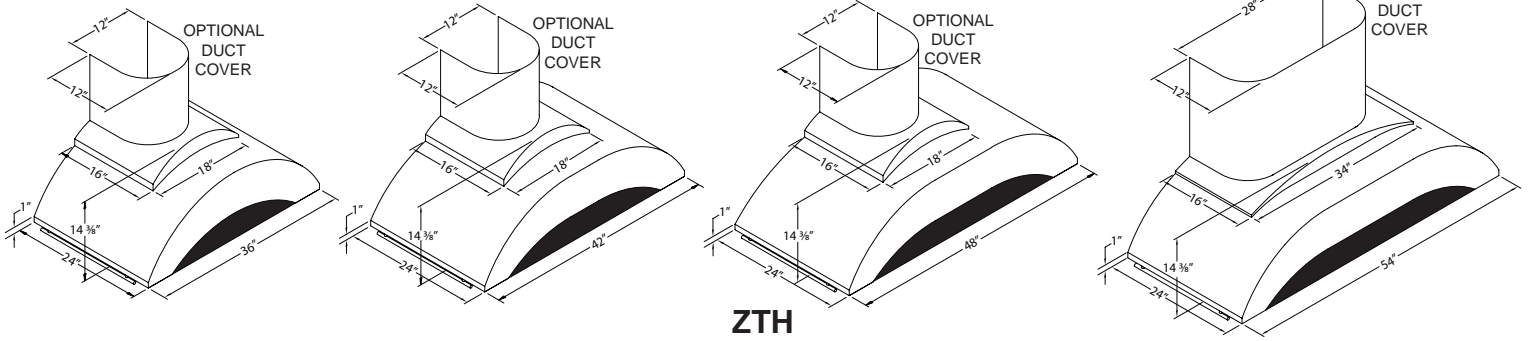

Connection Diagram (36"- 48" Widths)

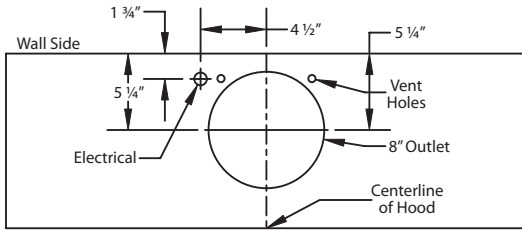

600 CFM B200 Dual Blower (Top View)

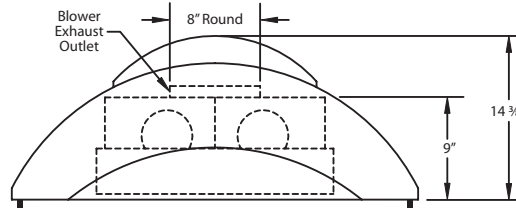

(Front View)

Recommended Mounting Height*

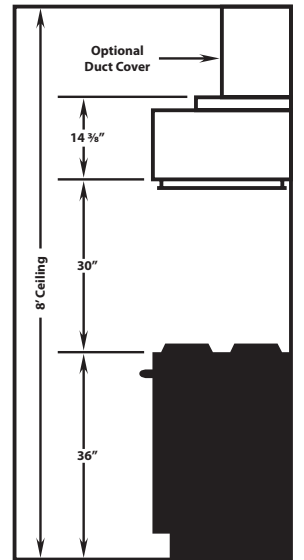

*Exceeding recommended mounting height may compromise performance.

NOTE: DUCT COVER EXTENDS 5 3/8" INTO TOP OF HOOD.

Connection Diagram (54" Width)

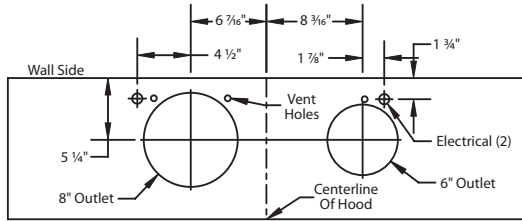

900 CFM B200 Dual Blower & B100 Single Blower (Top View)

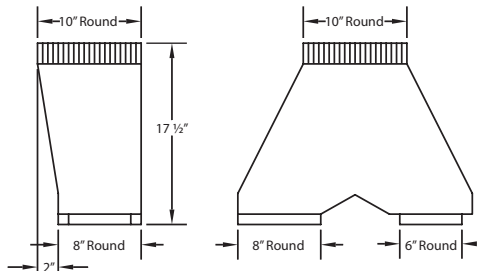

VP562 Transition (Optional) For B200 Dual and B100 Single Blower

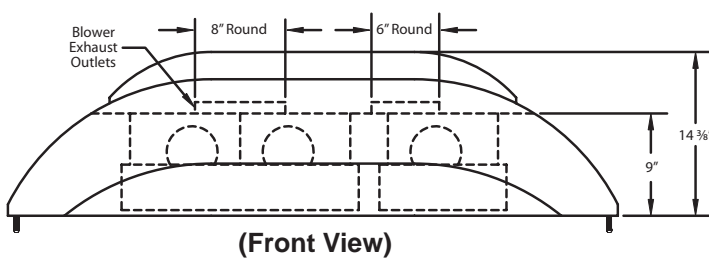

(Front View)

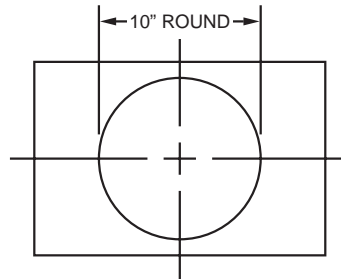

VP562 transition centers outlet over top of hood

Electrical/Mechanical Specifications For Blower Units

Model	Volts	Amps	Hz	RPM	CFM SP@0.0"	Equivalent CFM*	CFM SP@0.1"	CFM SP@0.2"	CFM SP@0.3"	Minimum Round Duct Size	Sones#
B200 Dual	115	4.9	60	1550	600	900	531	480	430	8" (50 in. ²)	6.5
B200 Dual & B100 Single	115	6.4	60	1550	900	1350	804	725	655	VP562: 10" (79 in. ²)	6.3

Hood has four halogen lights (one light in each corner).
 * Because the Magic Lung™ blower uses centrifugal filtration rather than conventional baffle or mesh filters, the Magic Lung™ blower can handle cooking equipment with higher cubic feet per minute (CFM) requirements and can deliver equivalent CFM much more efficiently than other filtration systems. When comparing the Magic Lung™ with other blower units made by other manufacturers, use the "Equivalent CFM".
 # Ratings in accordance with the Standard Test Code by the Energy Systems Laboratory of the Texas Engineering Experiment Station.

