

ASSEMBLY AND INSTALLATION INSTRUCTIONS

H0308

WARNING: TO AVOID RISK OF ELECTRICAL SHOCK, BE SURE TO SHUT OFF POWER BEFORE INSTALLING OR SERVICING THIS FIXTURE.

NOTES: 1. Before installing, consult local electrical codes for wiring and grounding requirements.
2. Read and save this instructions.

Hardware Package (included):

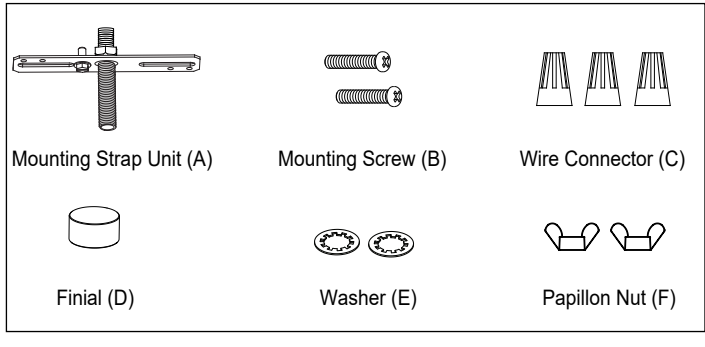

Installation Steps

Turn off the power at fuse or circuit box.

- Attach mounting strap unit (A) to outlet box by using two mounting screws (B).
Note: The depth of threaded pipe on the mounting strap unit may need to be adjusted to properly fit the fixture.

- Rod connections:
 - Thread the fixture wires from the fixture through the lower rod, then secure the lower rod onto fixture using the threaded pipe.
 - Thread the fixture wires through the middle rod, then secure the middle rod onto the lower rod using the threaded pipe.
 - Thread the fixture wires through the upper rod, then secure the upper rod onto the middle rod using the threaded pipe.
 - Thread the fixture wires through the connection head, then secure the connection head onto the upper rod using the threaded pipe.

Repeat the rod connection for the other side without wires.

Note: Length adjustable from 15-1/4" to 51-1/4". Use fewer rods if shorter length is desired.

- Thread the fixture wires through the plate, cover, washer (E) and papillon nut (F), secure them onto the connection head by tightening two papillon nuts (F).

- Connect the smooth wire from the fixture (marked) to black wire from the outlet box (power), the ribbed wire from the fixture (unmarked) to white wire from the outlet box (neutral) with the wire connectors (C) provided.

Connect the copper wire from the fixture to the mounting strap unit (A) by securing it with the green ground screw, then connect it to the house ground wire with wire connector (C). Carefully put all the wires into outlet box.

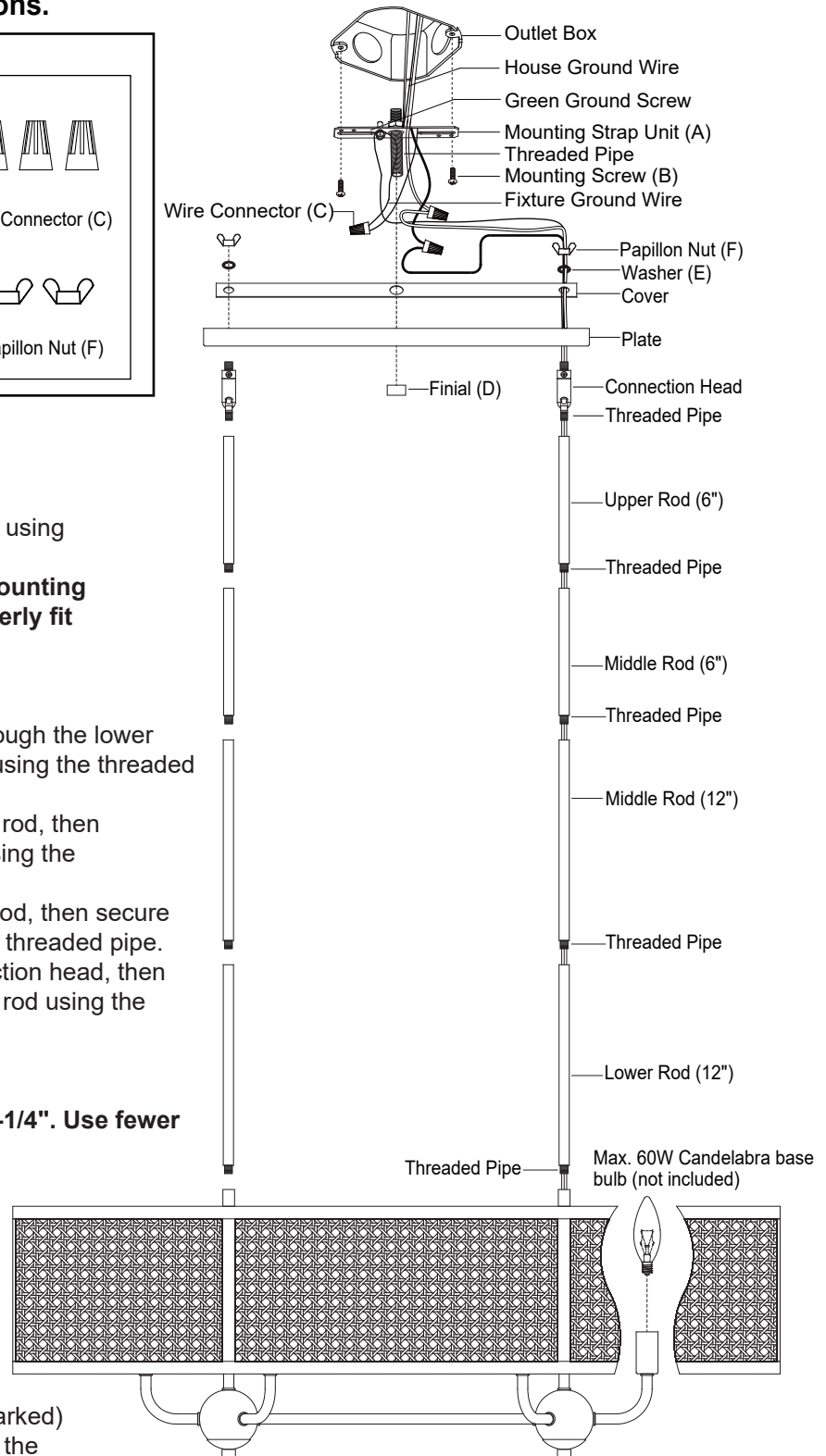

- Attach the plate to the mounting strap unit (A) by inserting the threaded pipe, then secure it with the finial (D).
- Install 6 x 60W Max. candelabra base bulbs (not included). **See relamping label at socket area or packaging for maximum wattage allowed.**

Turn on the power at fuse or circuit box.

The following parts are available for re-order if damaged or missing.

Spare Parts List:

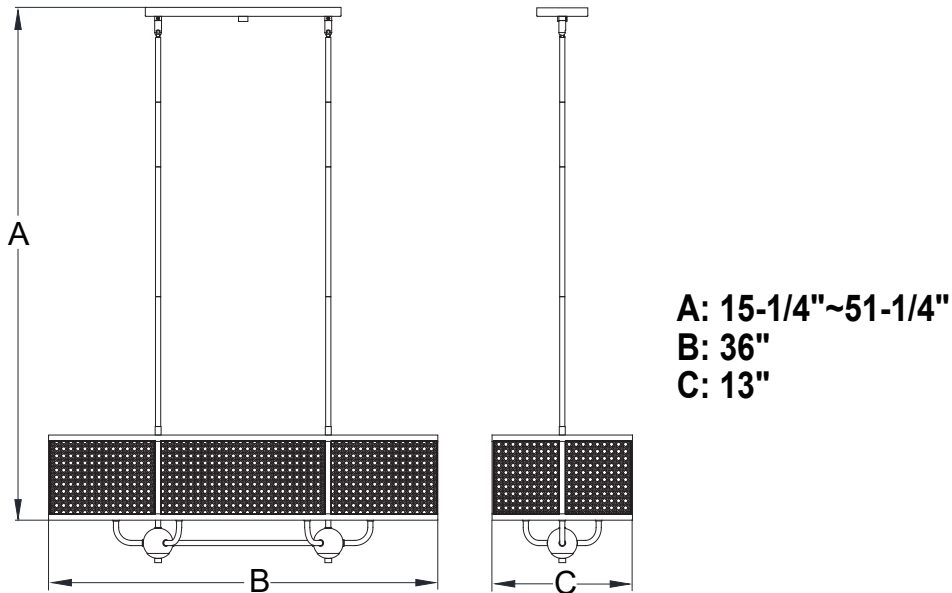
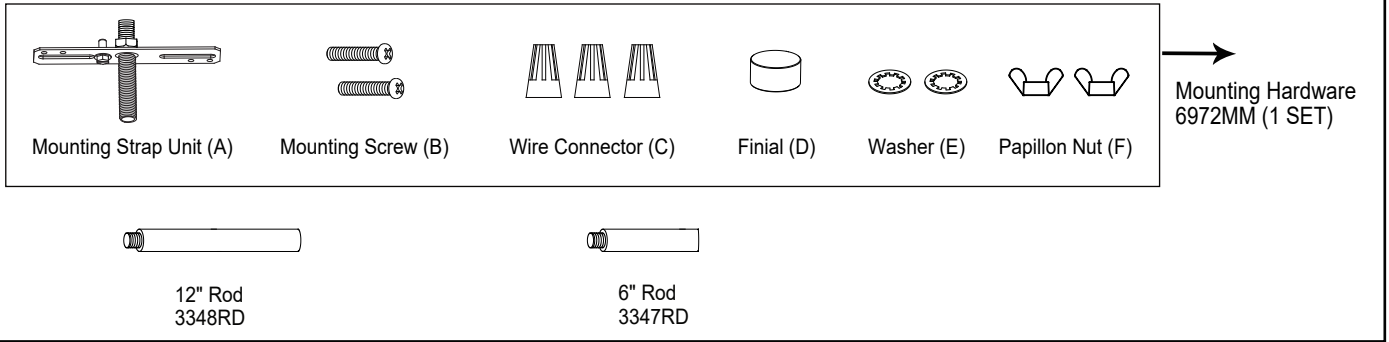

1 Year Warranty

Vaxcel warrants all of our products against defects in workmanship and finishes for one year following the date of shipment.

Exclusions: This warranty does not include the failure of products from extreme acts of nature; environmental conditions not suited for the products intended use; operation in temperatures outside of the range specified in the instruction manual; usage with improper power supply, power surges or dips. For coastal locations, some corrosion is considered normal for the environment.

Vaxcel reserves the right to repair, replace or issue a credit for any properly installed product, provided it is returned per RMA instruction. This warranty is limited to the cost of the product only and does not extend to transportation, installation or replacement costs.

How can warranty service be obtained?
 info@vaxcel.com
 1-800-482-9235