

ASSEMBLY AND INSTALLATION INSTRUCTIONS

T0778

WARNING: Turn off the main power at circuit breaker before installing fixture.
AVERTISSEMENT: Coupez la source d'alimentation principale au panneau central de disjoncteurs avant d'installer le luminaire.

NOTE: 1. Before installing, consult local electrical codes for wiring and grounding requirements.
2. Read and save these instructions.

Hardware Package (included):

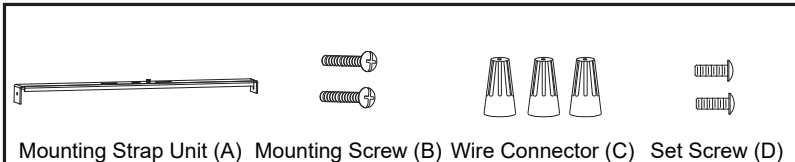

Installation Steps

Turn off the power at fuse or circuit box.

1. Unscrew the two set screws (D) partly around 2 turns only, remove the ceiling pan from the mounting strap unit (A).
2. Attach the mounting strap unit (A) to the outlet box by using two mounting screws (B).
3. Pull out the source wires from the outlet box. Make wire connections using wire connectors (C) as follows:
 - Connect the hot wire (black insulation) from the fixture to the black wire from the power source.
 - Connect the neutral wire (white insulation) from the fixture to the white wire from the power source.
 - Attach the fixture ground wire (bare wire) to the mounting strap unit (A) with the green ground screw, then depending on local code, connect it to the house ground wire with the wire connector (C).Carefully put all of the wires back into the outlet box.
4. Attach the ceiling pan to the mounting strap unit (A) by inserting two set screws (D) into the key holes on both sides, then rotate the ceiling pan until it is locked in place, finally secure the two set screws (D) tightly with screwdriver (not included).

Turn on the power at fuse or circuit box.

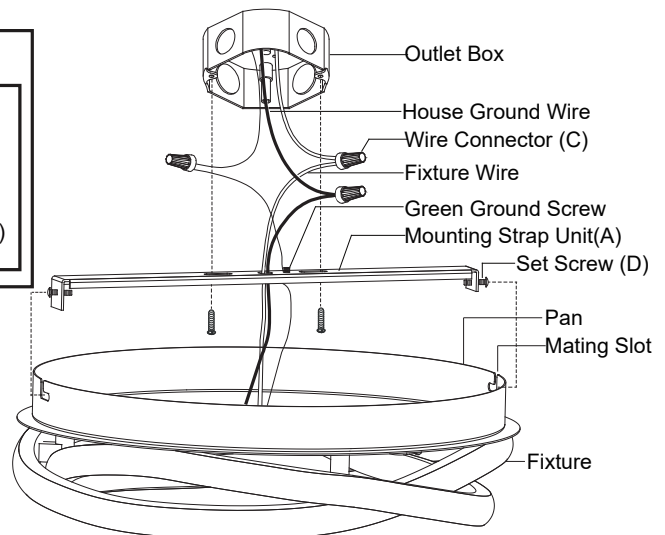

Note: This fixture is dimmable with a forward phase electronic dimmer. Dimmers tested to be compatible with this fixture are the Lutron: TGCL-153PH, MACL-153MH, SCL-153P, DVWCL-153PH.

If you are unfamiliar with electrical installations, it is recommended you have a qualified electrician for your installations.

The following parts are available for reorder if damaged or missing.

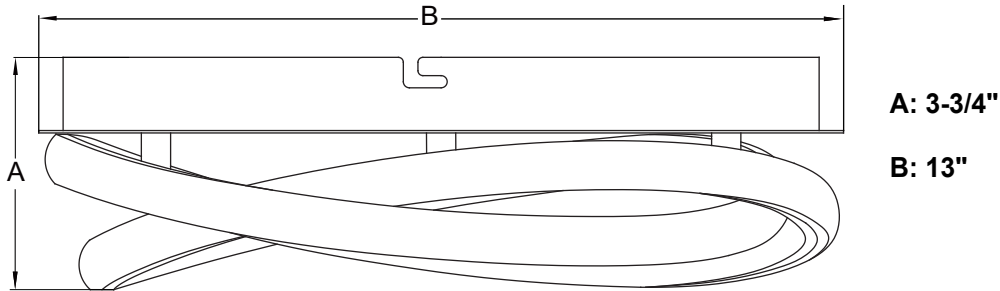
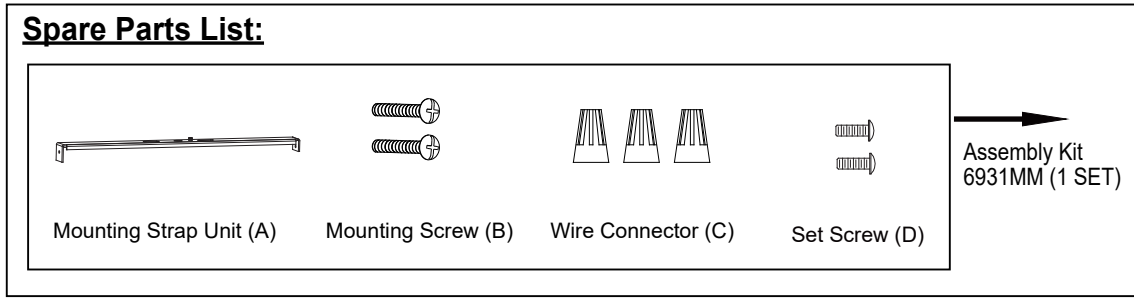

5 Year Limited Warranty

Vaxcel warrants all of our products against defects in workmanship and finishes for one year following the date of shipment.

In addition:

- Any product with an integrated motion sensor or dusk-to-dawn photocell is supported by a 5-year warranty for the functionality of the product.
- Any product with integrated LED modules is covered by a 5-year warranty on the LED functionality.

Exclusions: This warranty does not include the failure of products from extreme acts of nature; environmental conditions not suited for the products intended use; operation in temperatures outside of the range specified in the instruction manual; usage with improper power supply, power surges or dips. For coastal locations, some corrosion is considered normal for the environment.

Vaxcel reserves the right to repair, replace or issue a credit for any properly installed product, provided it is returned per RMA instruction. This warranty is limited to the cost of the product only and does not extend to transportation, installation or replacement costs.

How can warranty service be obtained?

info@vaxcel.com
1-800-482-9235