

ASSEMBLY AND INSTALLATION INSTRUCTIONS

T0158

WARNING: TO AVOID RISK OF ELECTRICAL SHOCK, BE SURE TO SHUT OFF POWER WHILE INSTALLING OR SERVICING THIS FIXTURE.

NOTES: 1. Before installing, consult local electrical codes for wiring and grounding requirements.
2. READ AND SAVE THESE INSTRUCTIONS.

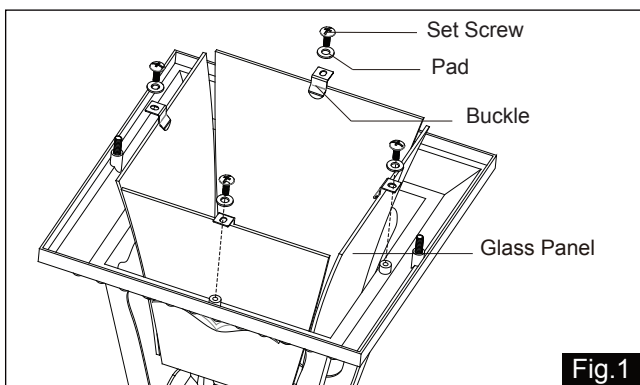
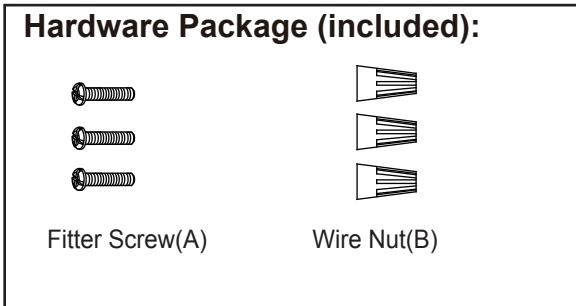

IMPORTANT:
The sensor has an excellent photocell function to enable the light to turn on at dusk and off at dawn automatically.

Installation Steps

Turn off the power at the main fuse or circuit breaker box.

- Place the glass panels into the main fixture carefully, secure the buckles to fix the glass panels by using four pads and four set screws.(See Fig.1)
- Install bulb(not included). See relamping label at socket area or packaging for maximum allowed wattage.
- Attach the dome to the main fixture and secure it with two rubber pads and two ball nuts.
- Pull out the source wires from the post. Make wire connections using wire nuts as follow:
 - Connect the hot wire (usually black insulation) from the fixture to the black wire from the post.
 - Connect the neutral wire (usually white insulation) from the fixture to the white wire from the post.
 - Attach the fixture grounding wire (usually green insulation or bare wire) to the grounding wire from the post.
 Carefully put the wires back into the post.
- Place the fitter on the post, then secure it with the fitter screws.
CAUTION: With silicone caulking compound, caulk completely around where the fitter meets with the post surface to prevent water from seeping into the post.

Turn on the power at the main fuse or circuit breaker box.

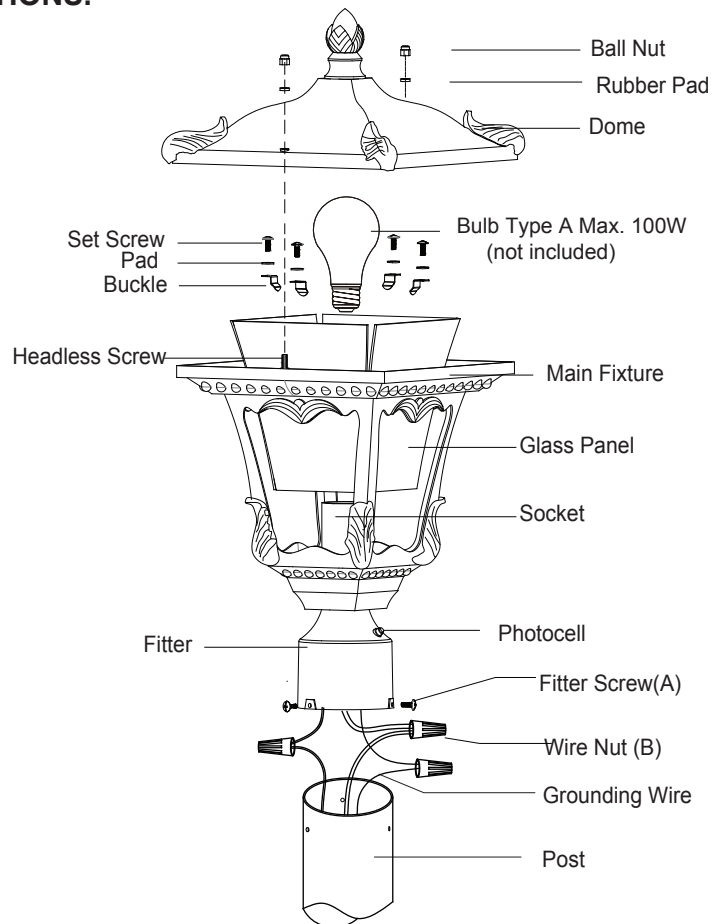

Operation the Unit Without Photocell

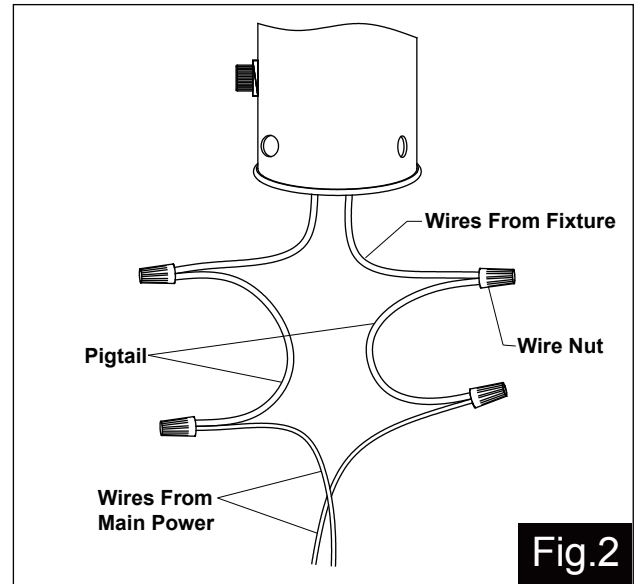
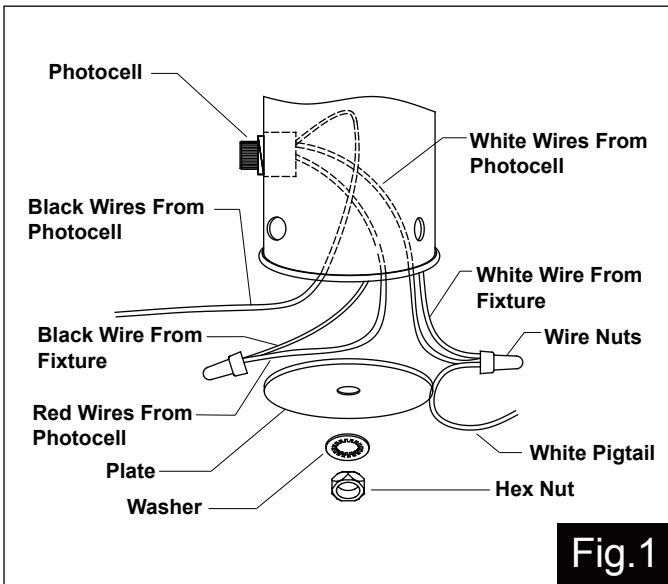

1. Turn off the power at the main fuse or circuit breaker box before starting installation.
2. Unscrew the hex nut and washer to remove the plate from the fixture.
3. Loosen the wire nuts connected with the wires from photocell. (See Fig.1)

Note: Do not move the photocell to prevent water from seeping into the post.
4. Take a white pigtail and black pigtail and make wire connections using wire nuts: (See Fig.2)
 - a. The black wire from the fixture to one end of the black pigtail.
 - b. The white wire from the fixture to one end of the white pigtail.
 - c. The other end of the black pigtail to the black wire from the power source.
 - d. The other end of the white pigtail to the white wire from the power source.
 Put all wires back into the post.

The following parts are available for re-order if damaged or missing.

Spare Parts List:

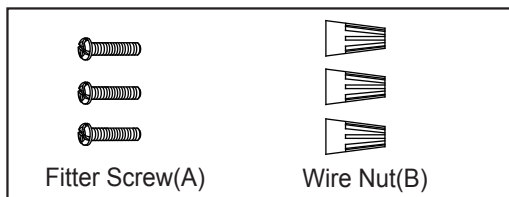

→ Assembly Kit
5182MM (1 SET) for T0158

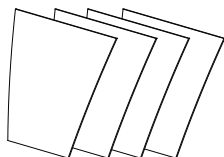

→ Hammered Glass
9647CH (1 SET) for T0158

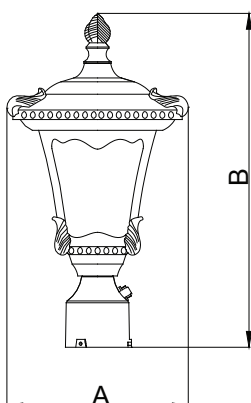

A: 9"
B: 16-3/4"