



Stainless Solid



Black Solid



White Solid

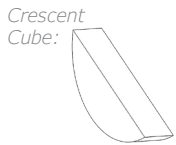

Key Features

- Makes crescent shaped cubes approx. 1/2" W x 3/4" H x 2 1/4" L
- Produces up to 23 lb of ice per day
- Stores 12 lb of ice
- On / off switch
- White interior
- Stainless steel handle (7/8" diameter)
- Field reversible door is shipped right-hand hinged
- Built-in or freestanding
- No drain required
- 230V model available. See u-line.com for details.

Model Details

Model	Voltage/Hz	Door Swing	Finish	Shipping Weight
UMCR114-SC01A	115 / 60	Field Reversible	Stainless Solid	65 lb (30 kg)
UMCR114-BC01A	115 / 60	Field Reversible	Black Solid	68 lb (31 kg)
UMCR114-WC01A	115 / 60	Field Reversible	White Solid	68 lb (31 kg)

Accessories

Model	Description	Finish	Shipping Weight
ULAWATERHOOKUP	Braided water supply line kit	N/A	2 lb

MCR114 • 14" Crescent Ice Maker • Marine Collection

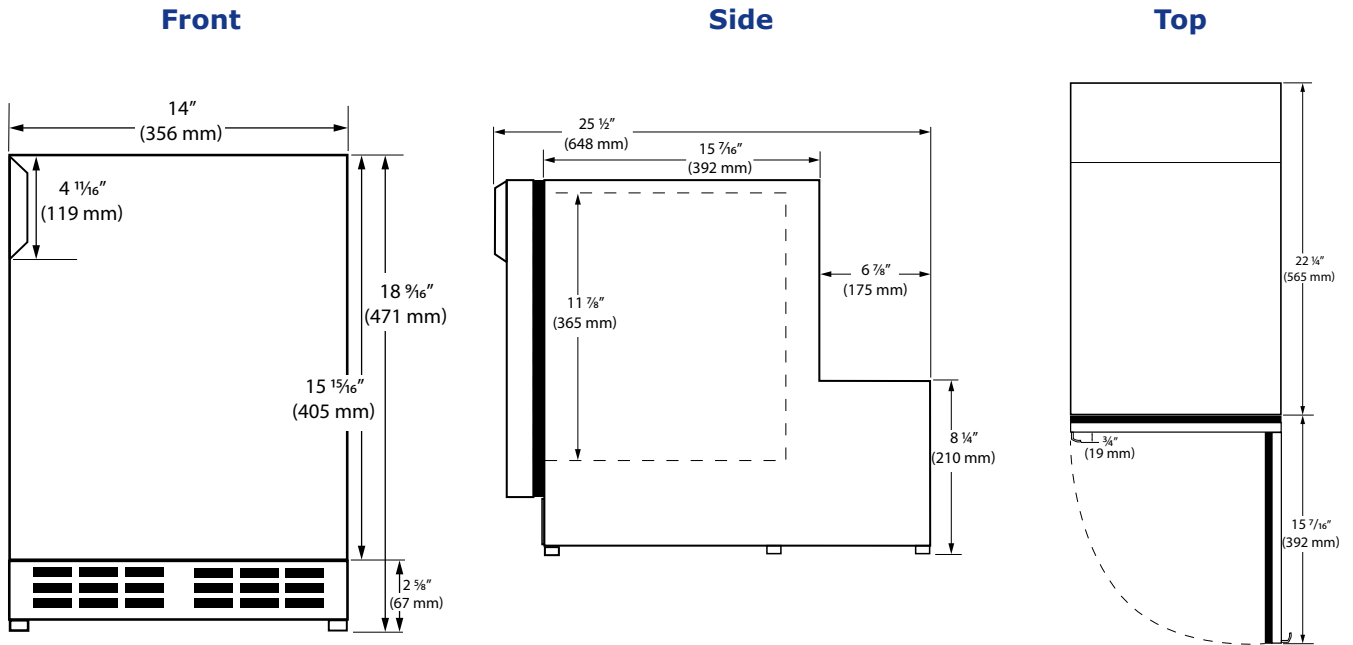

Specifications

Model	MCR114
Amps: Running	2.5 amps
Amps: Max Start Up	18 amps
Control Type	Mechanical Dial
Defrost Type	Manual
Dimensions: Product Depth	25 1/2" (648 mm)
Dimensions: Product Height	18 9/16" (471 mm)
Dimensions: Product Width	14" (356 mm)
ENERGY STAR	N/A
Ice Production Per Day	23 lb (10,4 kg)
Product Weight: Max	59 lb (26,7 kg)
Refrigerant Type	R600A (1.34 oz)

Back

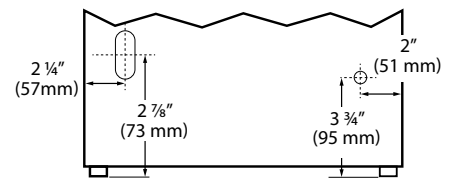

Cabinet Cut-Out

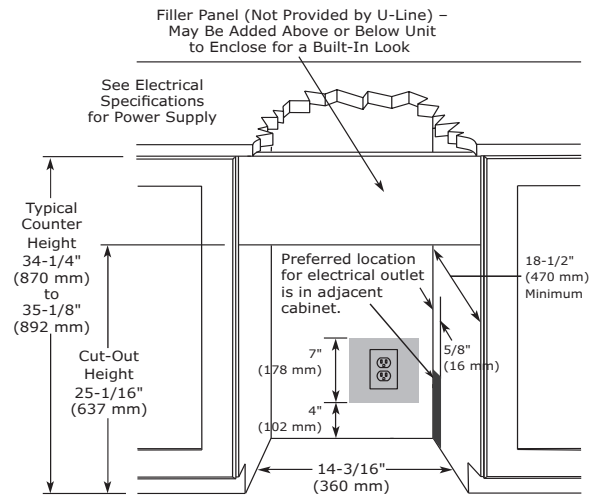

Installation Notes

- No additional clearance is needed for ventilation
- Do not obstruct front grille air flow

Warranty

- 1 Year (parts & labor) / 5 year sealed system (parts)
- + **Additional 1 Year (parts & labor) warranty at no cost with product registration**

See complete warranty for details

