



Stainless Frame



Stainless Solid



Integrated Frame



Integrated Solid



Black Solid



White Solid

Key Features

- **Industry Leading: BrightShield antimicrobial lighting creates a clean environment for food and beverages** **select models
- Convection cooling system provides a quick cool down and consistent temperature
- Extended lower interior maximizes storage options
- Black interior
- LowE coated, argon gas filled, dual thermopane glass door provides protection from harmful UV Light
- Stainless steel full-wrap door and handle (7/8" diameter)
- Stainless steel grille (stainless model), black metal grille (black, & integrated model requires 3/4" custom door panel and handle (not supplied by U-Line) white, & integrated models)
- One slide-out black metal shelf
- Three tempered glass shelves
- Digital touch pad control
- Temperature range: 34°F to 60°F
- Bright white LED lighting (on non-BrightShield models)
- Volume of 5.7 cu ft holds up to 123 bottles (12 oz) or 185 cans (12 oz)
- Field reversible door is shipped right-hand hinged
- Built-in or freestanding
- Four adjustable leveling legs

Model Details

Model	Voltage/Hz	Door Swing	Finish	Shipping Weight
UHRE124-SG01A	115 / 60	Field Reversible	Stainless Frame	120 lb
UHRE124-SG81A **BrightShield Lighting	115 / 60	Field Reversible	Stainless Frame	120 lb
UHRE124-SS01A	115 / 60	Field Reversible	Stainless Solid	110 lb
UHRE124-SS81A **BrightShield Lighting	115 / 60	Field Reversible	Stainless Solid	110 lb
UHRE124-IG01A	115 / 60	Field Reversible	Integrated Frame	115 lb
UHRE124-IG81A **BrightShield Lighting	115 / 60	Field Reversible	Integrated Frame	115 lb
UHRE124-IS01A	115 / 60	Field Reversible	Integrated Solid	105 lb
UHRE124-IS81A **BrightShield Lighting	115 / 60	Field Reversible	Integrated Solid	105 lb
UHRE124-BS01A	115 / 60	Field Reversible	Black Solid	110 lb
UHRE124-BS81A **BrightShield Lighting	115 / 60	Field Reversible	Black Solid	110 lb
UHRE124-WS01A	115 / 60	Field Reversible	White Solid	110 lb
UHRE124-WS81A **BrightShield Lighting	115 / 60	Field Reversible	White Solid	110 lb

Accessories

Model	Description	Finish	Shipping Weight
ULAFREESTANDB	Freestanding Kit	Black	3 lb

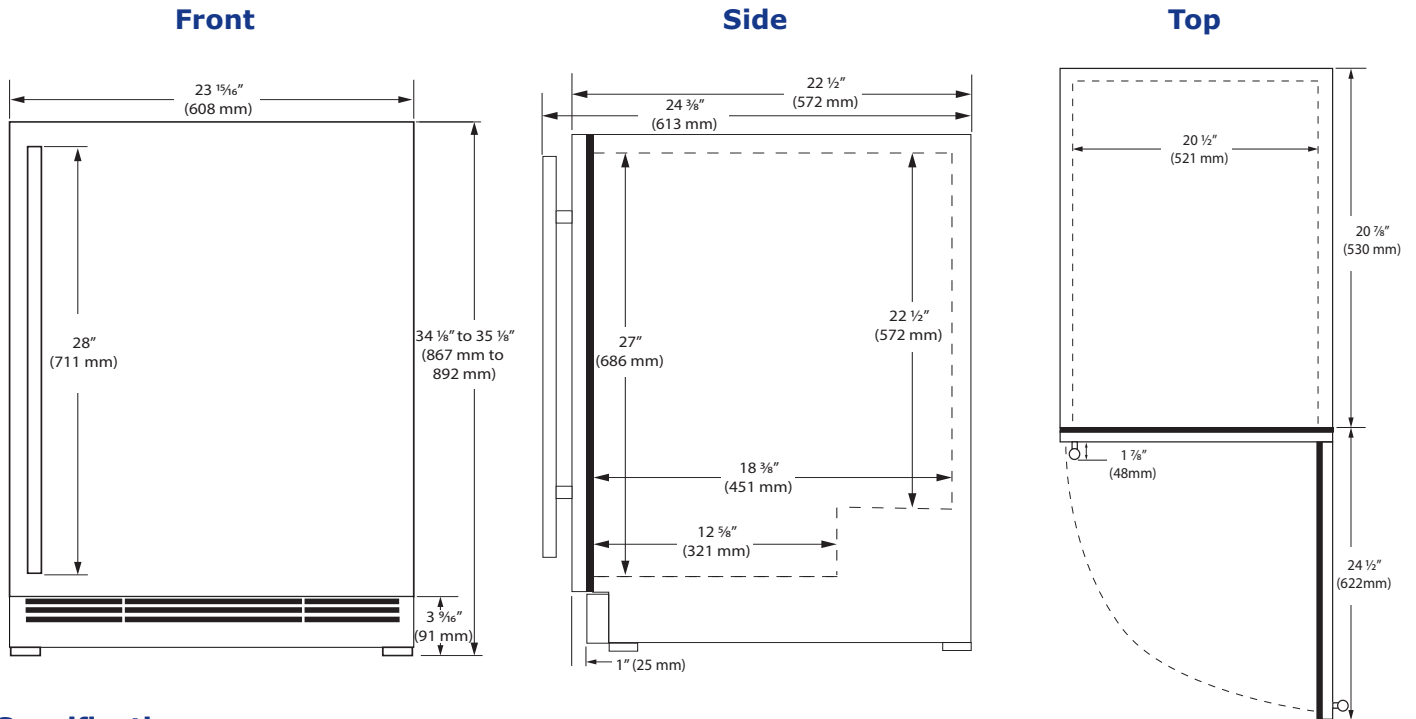

Specifications

Model	HRE124
Amps: Running (115 v)	1.2 A
Capacity Bottle	123
Capacity Can	185
Capacity: Total Volume (cu ft)	5.7 cu ft
Dimensions: Product Depth	22 1/2" / 572 mm
Dimensions: Product Height	34 1/8" / 867 mm
Dimensions: Product Width	23 15/16" / 608 mm
ENERGY STAR (Glass)	No
ENERGY STAR (Solid)	Tier 3
Energy Consumption: Avg. Per Year	310 kWh
Panel Height	30 1/4" / 768 mm
Panel Thickness	3/4" / 20 mm
Panel Type	2 3/4" / 70 mm Frame or Solid Panel
Panel Width	23 3/4" / 603 mm
Refrigerant Type	R600a (1.23 oz)
Sabbath (Star K Certified)	Yes
Temperature Range	34°F to 60°F

Back

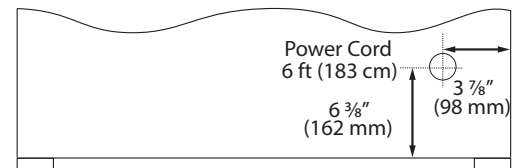

Cabinet Cut-Out

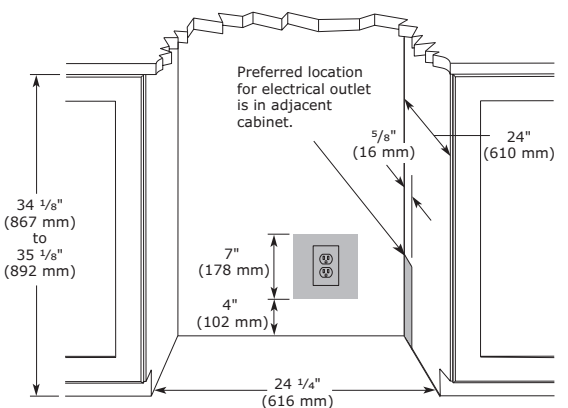

Warranty

- 1 Year (parts & labor) / 5 year sealed system (parts)
- + **Additional 1 Year (parts & labor) warranty at no cost with product registration**

See complete warranty for details



Installation Notes

- 24" cutout width sufficient if door protrudes beyond adjacent cabinetry
- No additional clearance is needed for ventilation
- Do not obstruct front grille air flow

