



Stainless Solid



Integrated Solid



Black Solid



White Solid

Key Features

- Volume of 4.2 cu ft holds up to 61 bottles (12 oz) or 114 cans (12 oz)
- Digital Touch Pad Control
- Refrigerator temperature range: 34°F - 45°F
- Produces and stores up to 8 lbs of ice per day
- Crescent ice cube dimensions: 1/2" W x 3/4" H x 2 1/4" L
- White interior is illuminated with LED lighting
- Three removable tempered glass shelves
- No drain required
- Stainless steel handle (7/8" diameter)
- Integrated model requires 3/4" custom door panel and handle (not supplied by U-Line)
- Field reversible door is shipped right-hand hinged
- Built-in or freestanding
- Four adjustable leveling legs

Model Details

Model	Voltage/Hz	Door Swing	Finish	Shipping Weight
UHRI124-SS01A	115 / 60	Field Reversible	Stainless Solid	129 lb
UHRI124-IS01A	115 / 60	Field Reversible	Integrated Solid	126 lb
UHRI124-BS01A	115 / 60	Field Reversible	Black Solid	129 lb
UHRI124-WS01A	115 / 60	Field Reversible	White Solid	129 lb

Accessories

Model	Description	Finish	Shipping Weight
ULAFREESTANDB	Freestanding Kit	Black	3 lb
ULAWATERHOOKUP	Braided Water Supply Line Kit	N/A	2 lb

HRI124 • 24" Refrigerator / Ice Maker • 1 Class

Front

Dimensions shown apply to all finishes, including Integrated (INT) models with 3/4" integrated panel/frame installed.

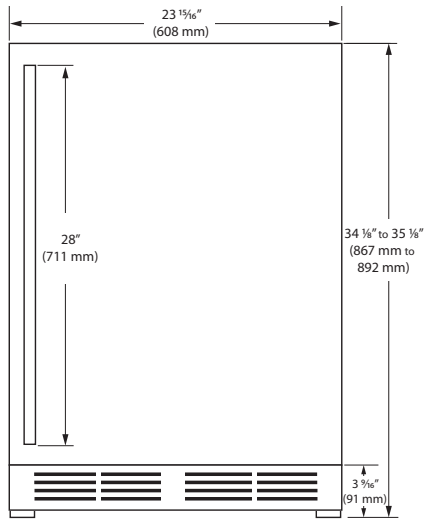

Side

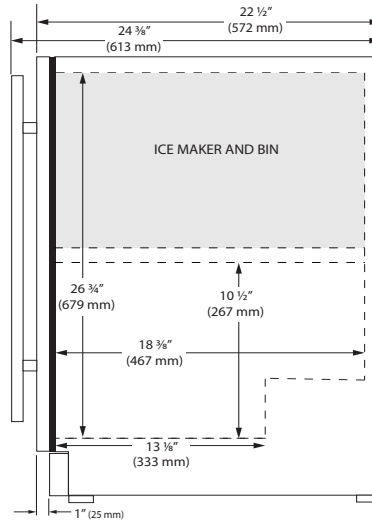

Top

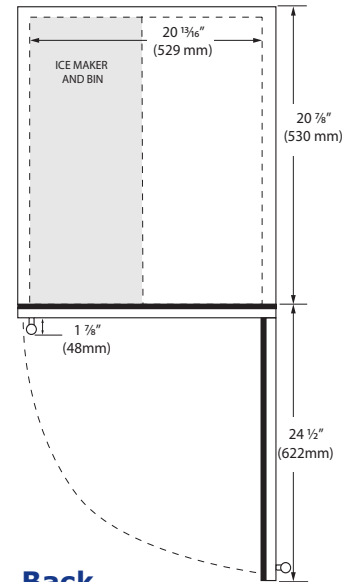

Back

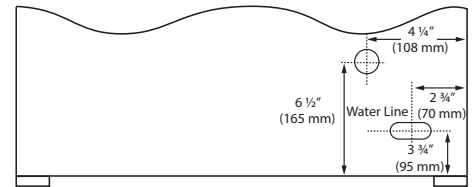

Cabinet Cut-Out

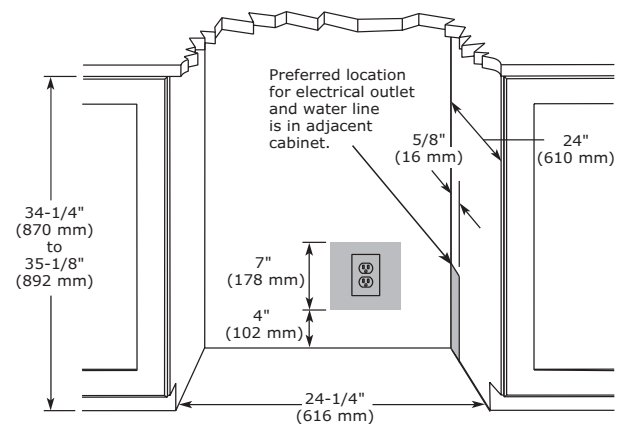

Specifications

Model	HRI124
Amps: Running	2.4
Capacity: Refrigerator Volume (cu ft)	4.2
Capacity: Bottle	61 (12oz)
Capacity: Can	114 (12oz)
Defrost Type	Frost Free
Dimensions: Product Depth	22 1/2" / 572 mm
Dimensions: Product Height	34 1/8" / 867 mm
Dimensions: Product Width	23 15/16" / 608 mm
Energy Consumption: Avg. Per Year	575 kWh
Ice Production Per Day	8 lb
Ice Storage	8 lb
Panel Height	30 1/4" / 768 mm
Panel Thickness	3/4" / 20 mm
Panel Type	Solid Panel
Panel Width	23 3/4" / 603 mm
Product Weight: Max	119 lb
Refrigerant Type	R600a (1.34 oz)
Sabbath (Star K Certified)	Yes
Temperature Range	34°F - 45°F

Installation Notes

- No additional clearance is needed for ventilation
- Do not obstruct front grille air flow

Warranty

- 1 Year (parts & labor) / 5 year sealed system (parts)
- + **Additional 1 Year (parts & labor) warranty at no cost with product registration**

See complete warranty for details



Please visit u-line.com to view this model's User Guide & Service Manual. All Specifications are subject to change without notice.

8900 North 55th Street • Milwaukee, Wisconsin 53223 USA • +1.414.354.0300 • sales@u-line.com • u-line.com