

ANB115

15" Nugget Ice • ADA Collection



Stainless Solid

Key Features

- **Industry Exclusive: U-Choose™ feature offers five levels of ice density**
- **Industry Leading: Produces up to 90 lb of ice per day**
- **Industry Leading: Stores 30 lb of ice**
- Eco friendly - most efficiency type of specialty ice
- Makes cylindrical compressed ice bits approx. 3/4" L x 1/2" H
- Digital touch pad control with blue LED display
- Indicator alert notifies user when cleaning is needed
- Bright white LED lighting
- White interior
- Stainless steel handle (7/8" diameter)
- Easiest nugget ice machine cleaning process in the industry
- Field reversible door is shipped right-hand hinged
- Built-in or freestanding
- Four adjustable leveling legs
- Factory installed drain pump model recommended if a gravity drain is not accessible

Model Details

Model	Voltage/Hz	Door Swing	Pump	Finish	Shipping Weight
UANB115-SS01A	115 / 60	Field Reversible	-	Stainless Solid	90 lb
UANP115-SS01A	115 / 60	Field Reversible	Pump Included	Stainless Solid	95 lb

ACCESSORIES

Model	Description	Finish	Shipping Weight
ULANUGGETCLEAN	Nugget Ice Cleaner (Single 8 oz. bottle)	N/A	1 lb
ULAWATERHOOKUP	Braided Water Supply Line Kit	N/A	2 lb

Front

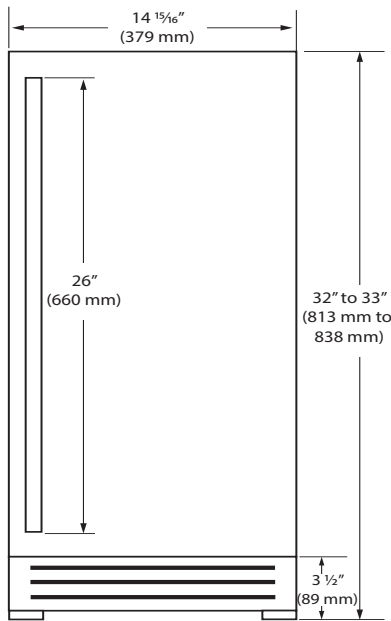

Side

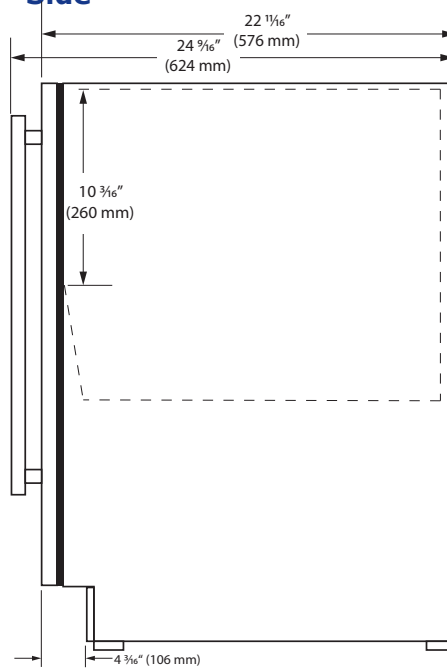

Top

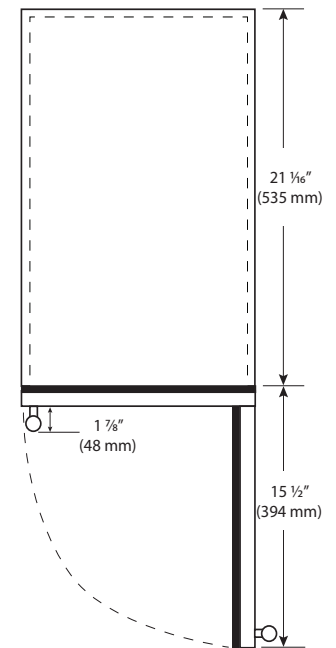

Specifications

Model	ANB115
Amps: Running	3
Dimensions: Product Depth	22 11/16" / 576 mm
Dimensions: Product Height	32" / 813 mm
Dimensions: Product Width	14 15/16" / 379 mm
ENERGY STAR	Yes
Ice Production Per Day	90 lb
Ice Storage	30 lb
Product Weight: Max	95 lb
Refrigerant Type:	R600a
Sabbath (Star K Certified)	YES

Back

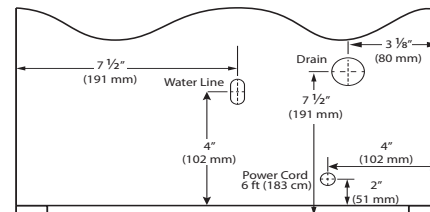

Cabinet Cut-Out

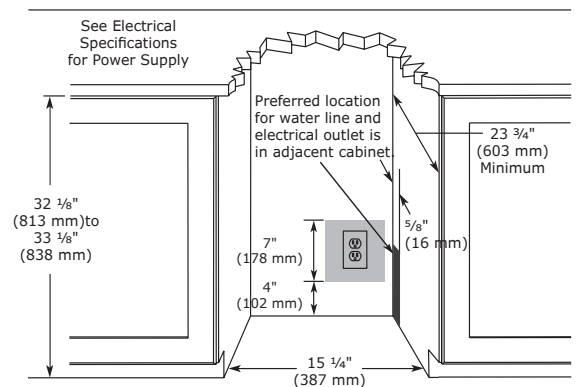

Warranty

- 1 Year (parts & labor) / 5 year sealed system (parts)
- **2 Year (parts & labor) / 5 year sealed system (parts) upgrade at no cost with product registration**



See complete warranty for details

Installation Notes

- 15" cutout width sufficient if door protrudes beyond adjacent cabinetry
- No additional clearance is needed for ventilation
- Do not obstruct front grille air flow



Please visit u-line.com to view this model's User Guide & Service Manual. All Specifications are subject to change without notice.