

## HRE518 • 18" Refrigerator • 5 Class



Stainless Frame



Stainless Solid



Integrated Frame



Integrated Solid

### Additional Options

- Accessory panels are designed for easy installation on Integrated models



Stainless Handleless Panel

### Key Features

- **Industry Exclusive: Full-depth lower interior maximizes storage options**
- **Industry Leading: Variable speed compressor delivers maximum energy efficiency, faster temperature response, and quieter operation**
- Stainless steel interior
- Stainless steel cabinet, toe kick, and accents
- U-Adjust™ Interior: 19 adjustable positions
- Three removable, full-extension Slide & Secure™ Bins
- Convection cooling system provides a quick cool down and consistent temperature
- Temperature range: 33°F - 70°F
- Adjustable bright white or blue LED lighting
- Soft close door with articulating hinge
- Volume of 3.7 cu ft holds up to 61 bottles (12 oz) or 100 cans (12 oz)
- Digital touch pad control with blue LED display
- Stainless steel handle (7/8" diameter)
- Integrated model requires 3/4" custom door panel and handle (not supplied by U-Line)
- Field reversible door is shipped right-hand hinged
- Built-in or freestanding
- Four adjustable leveling legs

### MODEL DETAILS

Model	Voltage/Hz	Door Swing	Finish	Shipping Weight
UHRE518-SG01A	115 / 60	Field Reversible	Stainless Frame	128 lb
UHRE518-SS01A	115 / 60	Field Reversible	Stainless Solid	115 lb
UHRE518-IG01A	115 / 60	Field Reversible	Integrated Frame	124 lb
UHRE518-IS01A	115 / 60	Field Reversible	Integrated Solid	109 lb

### ACCESSORIES

Model	Description	Finish	Shipping Weight
ULAGRILLE18	Adjustable Grille (Accepts Integrated Panel)	Black	1.5 lb
ULASHP18FRAME*	Stainless Handleless Panel Frame	Stainless	8 lb
ULASHP18SOLID*	Stainless Handleless Panel Solid	Stainless	12 lb

# HRE518 • 18" Refrigerator • 5 Class

## Dimensions

### Front

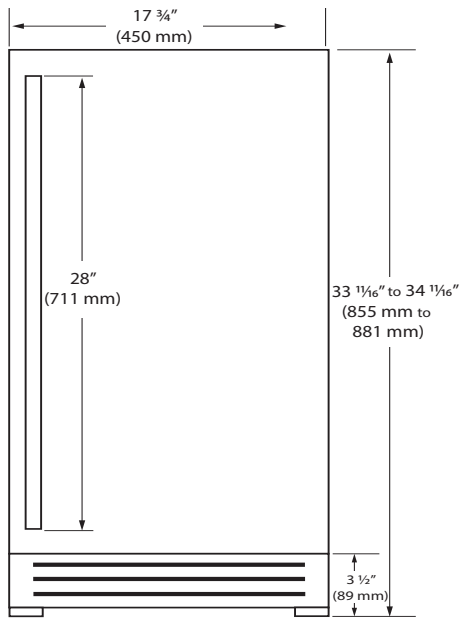

### Side

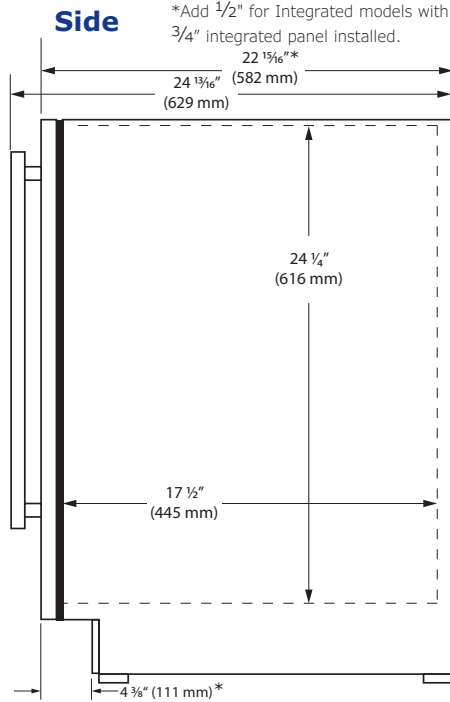

### Top

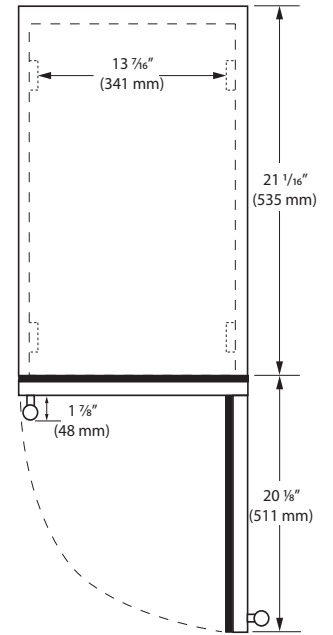

## Specifications

Model	HRE518
Amps: Running	1.2
Capacity: Bottle (12 oz)	61
Capacity: Can (12 oz)	100
Capacity: Volume (cu ft)	3.7
Capacity: Wine Bottle (750 ml)	N/A
Dimensions: Product Depth	22 15/16" / 583 mm
Dimensions: Product Height (Min.)	33 1/16" / 855 mm
Dimensions: Product Width	17 3/4" / 450 mm
Energy Consumption: Avg. Per Year	260 - 290 kWh
ENERGY STAR (glass door)	No
ENERGY STAR (solid door)	Yes
Product Weight: Max	128 lb
Refrigerant Type:	R600a
Sabbath (Star K Certified)	Yes
Temperature Range	33°F - 70°F

### Back

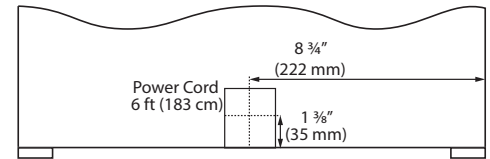

### Cabinet Cut-Out

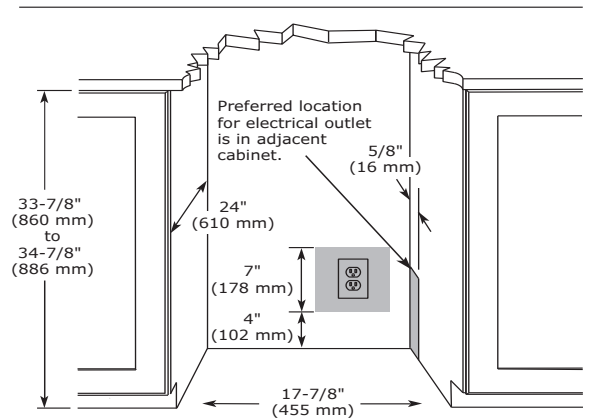

## Warranty

- 1 Year (parts & labor) / 5 year sealed system (parts)
- **2 Year (parts & labor) / 5 year sealed system (parts) upgrade at no cost with product registration**



See complete warranty for details

## Installation Notes

- No additional clearance is needed for ventilation
- Do not obstruct front grille air flow

