



Stainless Frame



Stainless Solid



Integrated Frame



Integrated Solid

### Additional Options

- Accessory panels are designed for easy installation on Integrated models



Stainless Handleless Panel

### Key Features

- **Industry Exclusive: Full-depth lower interior maximizes storage options**
- **Industry Leading: Variable speed compressor delivers maximum energy efficiency, faster temperature response, and quieter operation**
- Stainless steel interior
- Stainless steel cabinet, toe kick, and accents
- U-Adjust™ Interior: 19 adjustable positions
- Three removable, full-extension Slide & Secure™ Bins
- Convection cooling system provides a quick cool down and consistent temperature
- Temperature range: 33°F - 70°F
- Adjustable bright white or blue LED lighting
- Soft close door with articulating hinge
- Volume of 5.2 cu ft holds up to 94 bottles (12 oz) or 148 cans (12 oz)
- Digital touch pad control with blue LED display
- Stainless steel handle (7/8" diameter)
- Integrated model requires 3/4" custom door panel and handle (not supplied by U-Line)
- Field reversible door is shipped right-hand hinged
- Built-in or freestanding
- Four adjustable leveling legs

### MODEL DETAILS

Model	Voltage/Hz	Door Swing	Finish	Shipping Weight
UHRE524-SG01A	115 / 60	Field Reversible	Stainless Frame	163 lb
UHRE524-SS01A	115 / 60	Field Reversible	Stainless Solid	148 lb
UHRE524-IG01A	115 / 60	Field Reversible	Integrated Frame	156 lb
UHRE524-IS01A	115 / 60	Field Reversible	Integrated Solid	139 lb

### ACCESSORIES

Model	Description	Finish	Shipping Weight
ULAGRILLE24	Adjustable Grille (Accepts Integrated Panel)	Black	3 lb
ULASHP24FRAME*	Stainless Handleless Panel Frame	Stainless	10 lb
ULASHP24SOLID*	Stainless Handleless Panel Solid	Stainless	15 lb

\*Installs on integrated models.

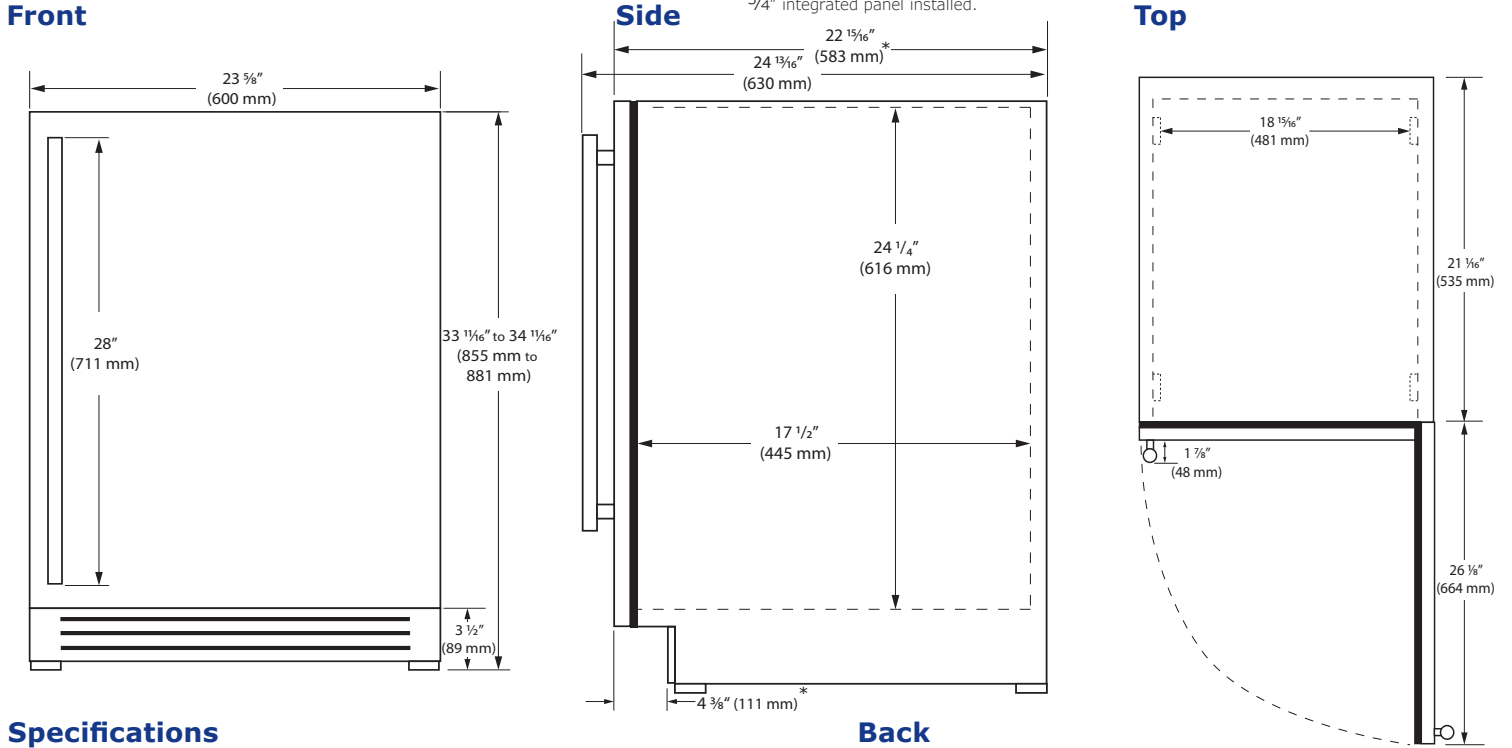

**Specifications**

Model	HRE524
Amps: Running	1.2
Capacity: Bottle (12 oz)	94
Capacity: Can (12 oz)	148
Capacity: Volume (cu ft)	5.2
Capacity: Wine Bottle (750 ml)	N/A
Dimensions: Product Depth	22 15/16" / 583 mm
Dimensions: Product Height (Min.)	33 1/16" / 855 mm
Dimensions: Product Width	23 5/8" / 600 mm
Energy Consumption: Avg. Per Year	275 - 305 kWh
ENERGY STAR (glass door)	No
ENERGY STAR (solid door)	Yes
Product Weight: Max	163 lb
Refrigerant Type:	R600a
Sabbath (Star K Certified)	Yes
Temperature Range	33°F - 70°F

**Cabinet Cut-Out**

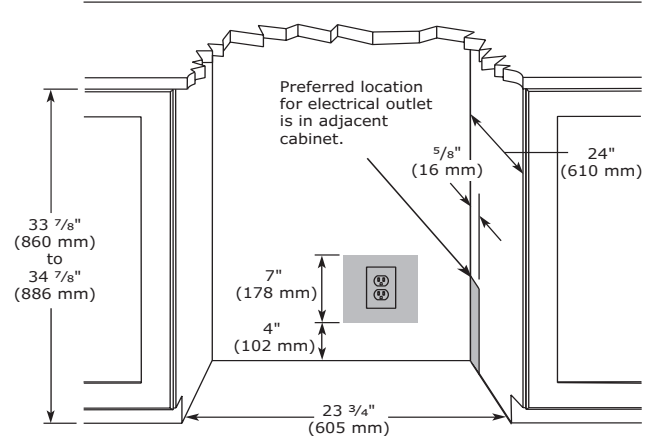

**Installation Notes**

- 1 Year (parts & labor) / 5 year sealed system (parts)

- **2 Year (parts & labor) / 5 year sealed system (parts) upgrade at no cost with product registration**



See complete warranty for details

- No additional clearance is needed for ventilation
- Do not obstruct front grille air flow



Please visit [u-line.com](http://u-line.com) to view this model's User Guide & Service Manual. All Specifications are subject to change without notice.