



TRUE FOOD SERVICE EQUIPMENT, INC.

2001 East Terra Lane • O'Fallon, Missouri 63366
 (636)240-2400 • Fax (636)272-2408 • (800)325-6152 • Intl Fax# (001)636-272-7546
 Parts Dept. (800)424-TRUE • Parts Dept. Fax# (636)272-9471 • www.truemfg.com

Project Name: _____

Location: _____

Item #: _____ Qty: _____

Model #: _____

A/A #

S/S #

Model:
TWT-60

Worktop:
Solid Door Refrigerator



Scan code for video

TWT-60

- ▶ True's worktop units are designed with enduring quality that protects your long term investment.
- ▶ Designed using the highest quality materials and components to provide the user with colder product temperatures, lower utility costs, exceptional food safety and the best value in today's food service marketplace.
- ▶ Oversized, environmentally friendly (134A) forced-air refrigeration system holds 33°F to 38°F (.5°C to 3.3°C).
- ▶ All stainless steel front, top and ends. Matching aluminum finished back. Top and backsplash are one piece formed construction. Bacteria and food particles cannot be trapped underneath as with other two-piece worktop units.
- ▶ Front breathing.
- ▶ Heavy duty PVC coated wire shelves.
- ▶ Foamed-in-place using Ecomate. A high density, polyurethane insulation that has zero ozone depletion potential (ODP) and zero global warming potential (GWP).

ROUGH-IN DATA

Specifications subject to change without notice. Chart dimensions rounded up to the nearest 1/8" (millimeters rounded up to next whole number).

Model	Doors	Shelves	Cabinet Dimensions (inches) (mm)			HP	Voltage	Amps	NEMA Config.	Cord Length (total ft.) (total m)	Crated Weight (lbs.) (kg)
			L	D†	H*						
TWT-60	2	4	60 3/8 1534	30 1/8 766	33 3/8 848	1/5 1/5	115/60/1 230-240/50/1	5.1 4.2	5-15P ▲	7 2.13	345 157

† Depth does not include 1" (26 mm) for rear bumpers.

* Height does not include 6 1/4" (159 mm) for castors or 6" (153 mm) for optional legs.

▲ Plug type varies by country.



APPROVALS:

AVAILABLE AT:

Model:
TWT-60

Worktop: Solid Door Refrigerator



STANDARD FEATURES

DESIGN

- True's commitment to using the highest quality materials and oversized refrigeration systems provides the user with colder product temperatures, lower utility costs, exceptional food safety and the best value in today's food service marketplace.

REFRIGERATION SYSTEM

- Factory engineered, self-contained, capillary tube system using environmentally friendly (CFC free) 134A refrigerant.
- Oversized, factory balanced refrigeration system with guided airflow to provide uniform product temperatures.
- Extra large evaporator coil balanced with higher horsepower compressor and large condenser; maintains cabinet temperatures of 33°F to 38°F (5°C to 3.3°C) for the best in food preservation.
- Sealed, cast iron, self-lubricating evaporator fan motors and larger fan blades give True worktop units a more efficient, low velocity, high volume airflow design. This unique design ensures faster temperature recovery and shorter run times in the busiest of foodservice environments.
- Condensing unit access in back of cabinet, slides out for easy maintenance.

CABINET CONSTRUCTION

- Exterior - stainless steel front, top and ends. Matching aluminum finished back. Top and backsplash are one piece formed construction. Bacteria and food particles cannot be trapped underneath as with other two-piece worktop units.
- Interior - attractive, NSF approved, white aluminum liner. Stainless steel floor with coved corners.

- Insulation - entire cabinet structure and solid doors are foamed-in-place using Ecomate. A high density, polyurethane insulation that has zero ozone depletion potential (ODP) and zero global warming potential (GWP).
- 5" (127 mm) diameter stem castors - locks provided on front set. 36" (915 mm) work surface height.

DOORS

- Stainless steel exterior with white aluminum liner to match cabinet interior.
- Each door fitted with 12" (305 mm) long recessed handle that is foamed-in-place with a sheet metal interlock to ensure permanent attachment.
- Positive seal self-closing doors with 90° stay open feature. Doors swing within cabinet dimensions.
- Magnetic door gaskets of one piece construction, removable without tools for ease of cleaning.

SHELVING

- Four (4) adjustable, heavy duty PVC coated wire shelves 27 1/2" L x 16" D (699 mm x 407 mm). Four (4) chrome plated shelf clips included per shelf.
- Shelf support pilasters made of same material as cabinet interior; shelves are adjustable on 1/2" (13 mm) increments.

MODEL FEATURES

- Evaporator is epoxy coated to eliminate the potential of corrosion.
- NSF-7 compliant for open food product.

ELECTRICAL

- Unit completely pre-wired at factory and ready for final connection to a 115/60/1 phase, 15 amp dedicated outlet. Cord and plug set included.



OPTIONAL FEATURES/ACCESSORIES

- Upcharge and lead times may apply.
 - 230 - 240V / 50 Hz.
 - 6" (153 mm) standard legs.
 - 6" (153 mm) seismic/flanged legs.
 - 2 1/2" (64 mm) diameter castors.
 - Barrel locks (factory installed). Requires one per door.
 - Single overshelf.
 - Double overshelf.
 - 28 1/4" (718 mm) deep, 1/2" (13 mm) thick, white polyethylene cutting board. Requires "L" brackets.
 - 28 1/4" (718 mm) deep, 1/2" (13 mm) thick, composite cutting board. Requires "L" brackets.
 - Heavy duty, 16 gauge tops.
 - Exterior rectangular digital thermometer (factory installed).
 - ADA compliant models with 34" (864 mm) work surface height.
 - Remote cabinets (condensing unit supplied by others; system comes standard with 404A expansion valve and requires R404A refrigerant). Consult factory technical service department for BTU information. All remote units must be hard wired during installation.

PLAN VIEW

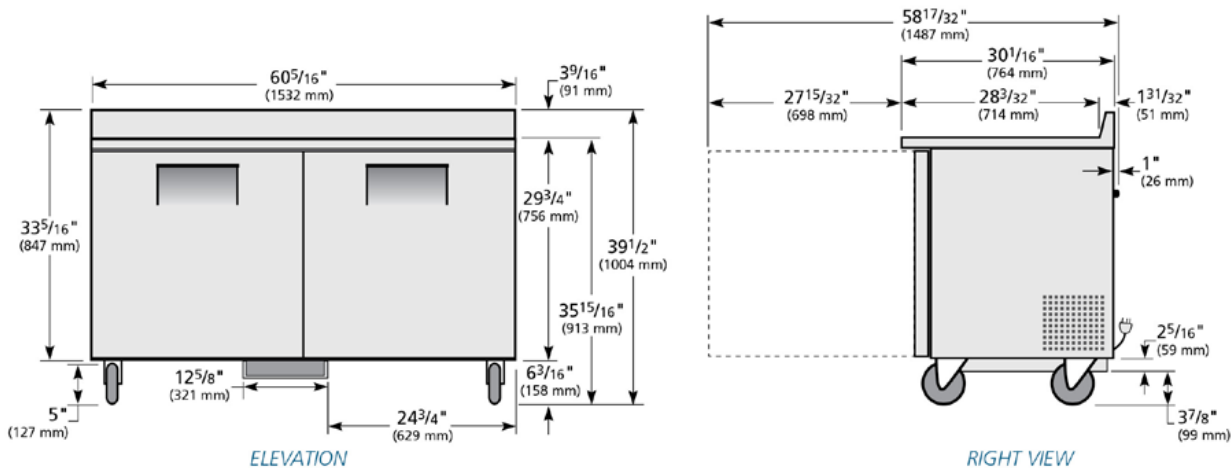

WARRANTY*
Three year warranty on all parts and labor and an additional 2 year warranty on compressor. (U.S.A. only)

METRIC DIMENSIONS ROUNDED UP TO THE NEAREST WHOLE MILLIMETER

SPECIFICATIONS SUBJECT TO CHANGE WITHOUT NOTICE



Model	Elevation	Right	Plan	3D	Back
TWT-60	TFPY03E	TFPY78S	TFPY03P	TFPY033	

*RESIDENTIAL APPLICATIONS: TRUE assumes no liability for parts or labor coverage for component failure or other damages resulting from installation in non-commercial or residential applications.

TRUE FOOD SERVICE EQUIPMENT