

Model:
TDD-4

Underbar Refrigeration: *Solid Swing Door Direct Draw Beer Dispenser*



TDD-4

- ▶ True's direct draw beer dispensers are designed with enduring quality and value. Our commitment to using the highest quality materials and oversized refrigeration assures colder product temperatures and years of trouble free service.
- ▶ Oversized, factory balanced, refrigeration system holds 33°F to 38°F (.5°C to 3.3°C).
- ▶ Exterior - heavy duty, wear resistant laminated black vinyl front and sides. Matching black aluminum back. All stainless steel counter top.
- ▶ Interior - Stainless steel floor with ½" (13 mm) reinforced lip and heavy gauge galvanized steel walls. NSF/ANSI Standard 7 compliant for packaged or bottled product.
- ▶ Two (2) 3" (77 mm) diameter stainless steel insulated beer columns. Cold air is directed into beer columns to reduce foaming and maximize draft beer profits.
- ▶ Entire cabinet structure and solid doors are foamed-in-place using a high density, polyurethane insulation that has zero ozone depletion potential (ODP) and zero global warming potential (GWP).

PLAN VIEW

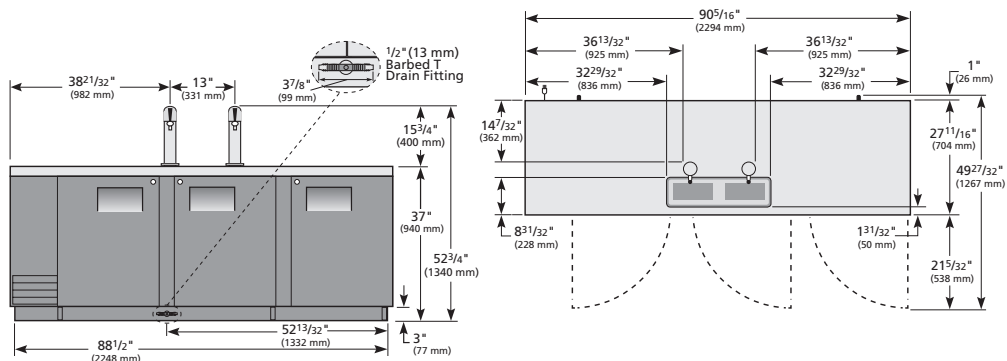

ROUGH-IN DATA

Specifications subject to change without notice.
Chart dimensions rounded up to the next whole millimeter (inches rounded up to the next 1/8").

Model	Doors	Capacity 1/2 Barrels	Cabinet Dimensions (mm)			HP	Voltage	Amps	Refrigerant	Crated Weight (kg)
			W	D†	H*					
TDD-4	3	4	2296	704	940	1/3	220-240V/50Hz	3.2	134A	243

† Depth does not include 26 mm for rear bumpers.

* Height does not include 400 mm for draft arms.