

Model:
TBB-4G-LD

Underbar Refrigeration:
Glass Swing Door Back Bar Cooler with LED Lighting

TBB-4G-LD

- ▶ True's refrigerated back bar coolers are designed with enduring quality and value. Our commitment to using the highest quality materials and oversized refrigeration assures colder product temperatures and years of trouble free service.
- ▶ Oversized, factory balanced, refrigeration system holds .5°C to 3.3°C.
- ▶ Exterior - all stainless steel countertop, heavy duty, wear resistant laminated black vinyl front and sides. Matching black aluminum back.
- ▶ Interior - Stainless steel floor with 13 mm reinforced lip and heavy gauge galvanized steel walls.
- ▶ NSF-7 approved for packaged and bottled product.
- ▶ Positive seal doors.
- ▶ Entire cabinet structure is foamed-in-place using Ecomate. A high density, polyurethane insulation that has zero ozone depletion potential (ODP) and zero global warming potential (GWP).
- ▶ LED interior lighting provides more even lighting throughout the cabinet. Safety shielded.



PLAN VIEW

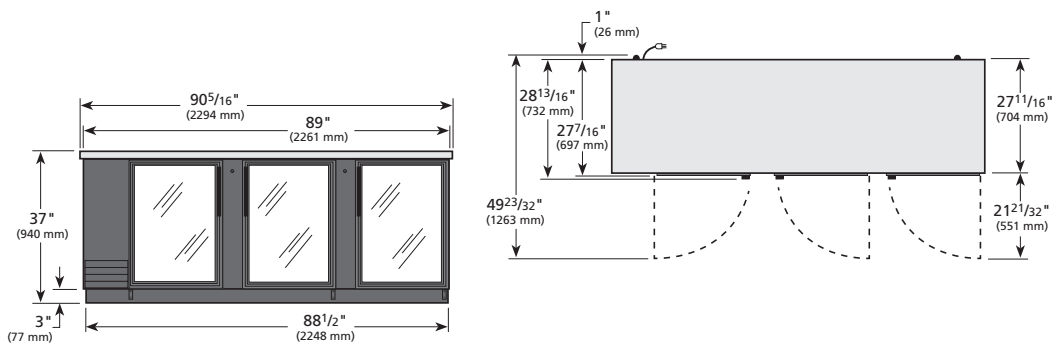

ROUGH-IN DATA

Voltage: 220-240V/50Hz

Specifications subject to change without notice. Chart dimensions rounded up to the next whole millimeter (inches rounded up to the next 1/8").

Model	Doors	Shelves	Cabinet Dimensions (mm)			AMP	Crated Weight (kg)	330ml bottles	50l barrel	Refrigerant	Refrigeration System
			W	D†	H						
TBB-4G-LD	3	6	2296	704	940	4,5	266	152 6-pks	4	R134A	Forced Air

† Depth does not include 26mm for rear bumpers and does not include 35mm for door handle