

Features

- Two sturdy, double door cabinets provides plenty of storage and is constructed of 304 stainless steel.
- Doors feature soft close hinges.
- 64" countertop made from 19 gauge 304 stainless steel.
- Single unit countertop fits over two single utility base units.
- One internal shelf board included in each cabinet base unit.
- Adjustable feet included for leveling cabinet.
- Four locking swivel casters and four fixed casters.
- UV-resistant. Clean, modern surfaces will not tarnish.
- Stainless steel surfaces resists stains and are easy to clean.

Warranty

- Lifetime Limited Residential Warranty

Specified Model

Model	OUC6424
Overall Dimensions	W64" x D24" x H37.3" L1625 x W610 x D947.4
Shipping Weight	122 lbs.
Material	0.6mm/304 stainless steel – Cabinet 19 GA./304 stainless steel – Countertop

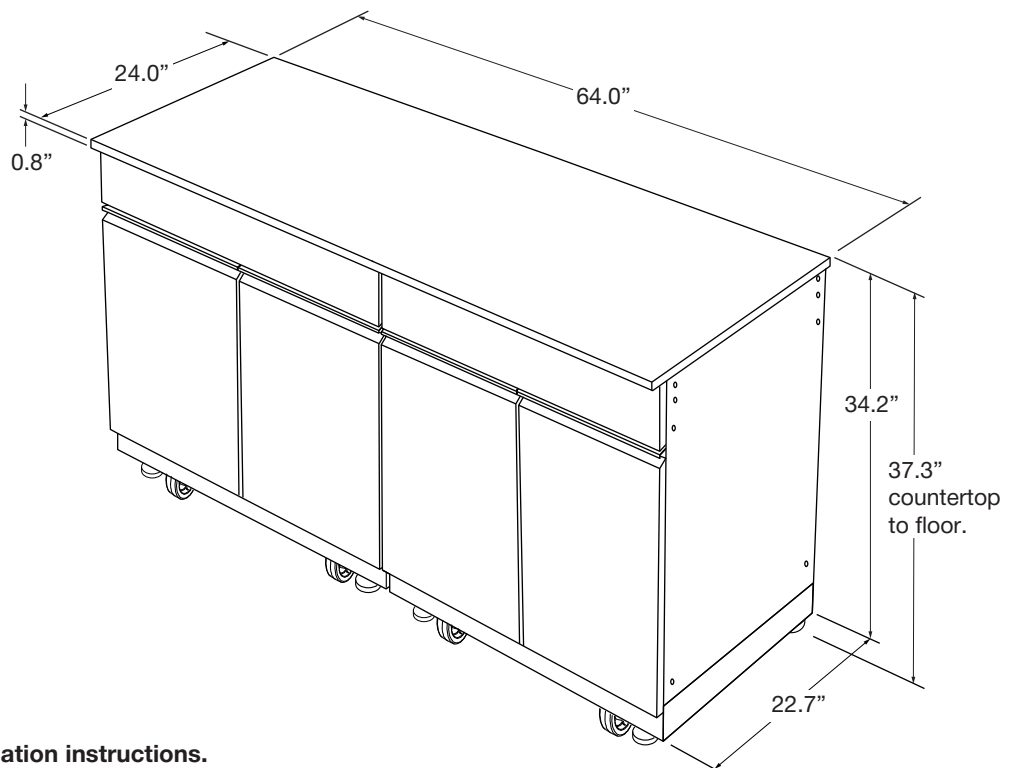

Codes/Standards

ASME A112.19.3/CSA B45.4

Notes:

Install this product according to the installation instructions.