

## Gooseneck EcoPower® Faucet

### FEATURES

- Self-generating hydropowered EcoPower system
- No minimum daily usage requirement
- Micro-sensor positioned underneath the spout head for accurate hand detection ensuring smooth and consistent water distribution
- Vandal resistant aerator housing
- Durable chrome plated spout body
- Single-hole mount
- Kit includes spout body, controller box, and mounting hardware - less supply lines
- Equipped with 1.0gpm flow control

### MODELS

- TEL151-D10E**
  - TELS151 (Gooseneck Spout)
  - TELC101R-D10E (Controller: 0.18gpc, 10 sec on-demand)
- TEL151-D10EM
  - **TEL151-D10E** (Gooseneck Spout Kit)
  - TLM10 (Mixing Valve)
- TEL151-D10ET
  - **TEL151-D10E** (Gooseneck Spout Kit)
  - TLT10R (Thermostatic Mixing Valve)

### COLORS/FINISHES

- #CP Polished Chrome

### OPTIONAL ACCESSORIES

- THP3158#CP - 4" Cover Plate
- THP3159#CP - 8" Cover Plate
- THP3094 - Laminar Flow Nozzle
- THP3237 - Swivel Coupling

### PRODUCT SPECIFICATION

TOTO Model # \_\_\_\_\_ The faucet shall have hydropowered self-generating, EcoPower System. The faucet shall have maximum of 10 seconds on-demand flow (0.18gpc). Product shall have anti-scald shape memory alloy thermostatic mixing valve (-ET models only). The faucet shall have self-adjusting sensor.



### CODES/STANDARDS

- Operates below federally mandated consumption limit of 0.25gpc
- Complies to California Green Building Code, CALGreen of 0.20 gpc
- Meets or exceeds ASME A112.18.1M/CSA B125.1, and NSF372-2011
- Certifications: IAPMO(cUPC), State of Massachusetts, and others
- California Green Code and City of Los Angeles Water Efficiency Ordinance
- ADA compliant
- Complies with federal and state statutes as low-lead (contains a weighted average of 0.25% lead or less)

\* For codes and standards of mixing valves TLM10 and TLT10R, please refer to corresponding product spec sheets.



# TEL151 Series

## Gooseneck EcoPower® Faucet

### SPECIFICATIONS

<b>Power Supply</b>	EcoPower
<b>Sensor Detection Range</b>	5-1/8" - 7-7/8" (130 - 200mm) Sensor is self-adjusting
<b>Water Supply Pressure</b>	Min (Dynamic/Flowing) Pressure: 15psi (100kPa) Max (Static) Pressure: 80 psi (551kPa)
<b>Water Supply</b>	G1/2 (1/2 NPSM compatible)
<b>Inlet Temperature Range</b>	32-110°F(0-42°C)
<b>Ambient Temperature</b>	32-104°F(0-40°C)
<b>Humidity</b>	Max. 90% RH
<b>Flow Rate</b>	0.18 gpc* - max 10 second On-Demand** (0.18 gpc = 1.0 gpm x 10/60 seconds) Equipped with 1.0 gpm flow control
<b>Warranty</b>	Three years

### NOTE

Following the federal mandate for water efficiency outlined in the Environmental Protection Act of 1992, faucets can be rated for water consumption based on two categories: Flow Rate and Water Consumption. TOTO uses the water consumption standard because it is the most accurate method of measuring water use. TOTO faucets also comply with the CALGreen Guideline of water usage.

#### Water Saving

On-Demand [10 sec.] faucet (0.18gpc)  
Federal Standard (0.25gpc) – 28% less  
CAL Green (0.20gpc) – 10% less

\*Gallons per cycle (gpc) is the amount of water per usage cycle .

\*\* On-demand refers to the way in which the water is dispersed (i.e.; water is only dispersed when the sensor is activated by the user as needed).

### Gooseneck

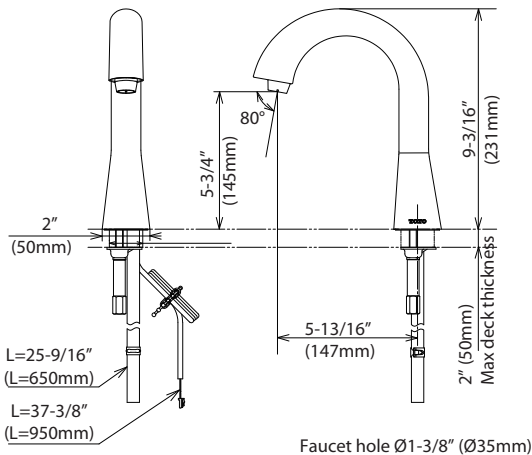

### Controller

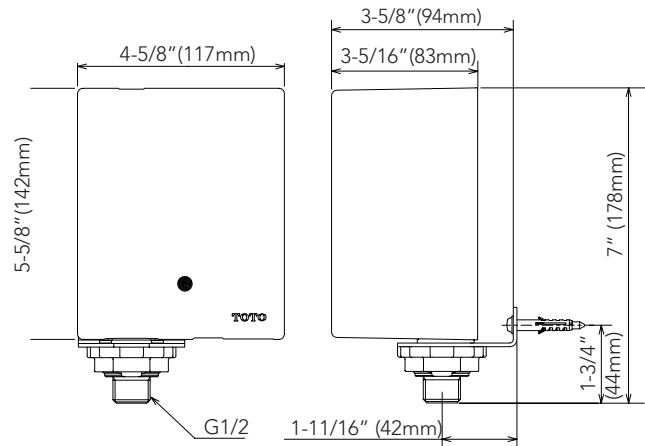

### Available Mixing Valves

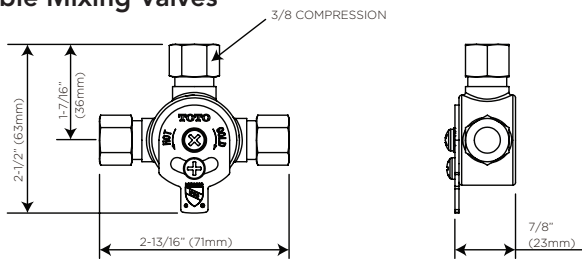

Hot/Cold Mixing Tee (TLM10)

Thermostatic Mixing Valve (TLT10R)

**TOTO**

These dimensions and specifications are subject to change without notice