



— BRINGING —  
**LUXURY &  
INNOVATION**  
TO THE COMFORT OF  
YOUR OWN  
HOME



1-877-288-8099

[www.thorkitchen.com](http://www.thorkitchen.com) | [info@thorgroup.us](mailto:info@thorgroup.us)





**Thor Kitchen is proud to offer you the experience to cook food like a true chef with our professional style appliances. With innovation, quality and performance, we can help you build a dream kitchen that brings excitement to your home.**



# STANDARDIZED QUALITY

- Every Thor Kitchen product is **CSA** certified.
- Wine coolers are **Intertek (ETL)** certified.
- Thor Kitchen ensures that every product is manufactured with 8 different safety and quality standard tests.
- We aim to provide affordable, professional style appliances to the general public. We want to give you an enjoyable cooking experience with our products.

## KEY RANGE PARTS & FEATURES



### HEAVY DUTY CONTINUOUS GRATES

Each grate is one single piece that can handle any size of cookware



### GAS VALVE IS SOURCED FROM SPAIN



### 15,000 BTU SEALED DUAL BURNER

Powerful dual burner with Extra Low 650 BTU Simmer Function

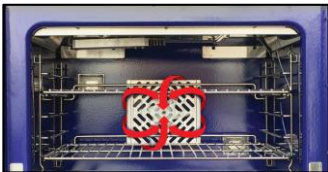

### BLUE PORCELAIN OVEN INTERIOR

Adding beauty & pleasure to your baking experience

**Reverse Direction Convection Fan** Provides controlled heat distribution for delicate baking

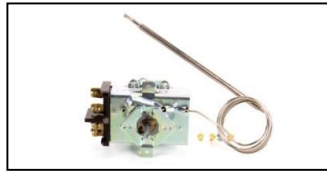

### USA MADE THERMOSTATS

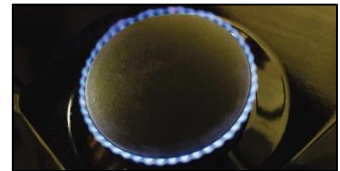

### 18,000 BTU SEALED SINGLE BURNER

A high powered burner designed to accommodate even the largest cookware

**Automatic Re-Ignition** if the burner flame extinguishes



### HEAVY DUTY HANDLE

For professional style and functionality

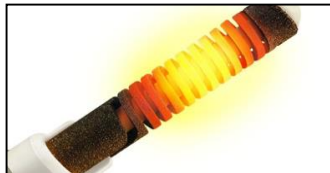

### USA MADE SURFACE IGNITOR



### INFRARED BROIL BURNER

High-End broiler radiates the heat to sear your food & seal in the juices

# HRG3080U

## 30-Inch Professional Stainless Steel Gas Range



### FEATURES

- Black Porcelain Drip Pan On Cook Top
- Blue Porcelain Oven Interior
- Heavy Duty Continuous Cast Iron Cooking Grates
- Automatic Re-Ignition Safety Feature
- Reverse Direction Commercial Convection Fan
- Two (2) Halogen Oven Interior Lights
- Thermostatically Controlled Oven Heating System
- CSA Certified ABS Control Knobs
- CSA Certified Unit

### BURNER PERFORMANCE

Total Number of Range Top Burners	4 Burners
Front Left Sealed Single Burner BTU	18,000
Front Right Sealed Dual Burner BTU	15,000
* Extra Low Simmer Function BTU	650
Rear Left Sealed Single Burner BTU	12,000
Rear Right Sealed Single Burner BTU	12,000

### OVEN PERFORMANCE

Oven Capacity	4.2 Cu. Ft.
U-Shaped Stove Burner BTU	22,000
Oven Broil Burner BTU	13,000

### TECHNICAL DETAILS

Fuel Type	Natural Gas / LP (See Accessory)
Electrical Requirements	120V
Circuit Breaker (A)	15 or 20 A
Frequency (Hz)	60 Hz

### DIMENSION & WEIGHT

Product Dimension (W x D x H) (in)	29 15/16" x 26" x 35 1/2"
Required Cutout Size (W x D x H) (in)	30 1/8" x 24"-25" x 35 1/2"
Product Net Weight	200 lbs.

### ACCESSORIES (NOT INCLUDED)

- Stainless Steel Island Trim
- Liquid Propane Gas Conversion Kit
- High Altitude Conversion Kits for LP/Natural Gas

### WARRANTY

2 Year Warranty On Parts and Labor





# HRG3026U

## 30-Inch Professional Stainless Steel Gas Range



### FEATURES

- Black Porcelain Drip Pan On Cook Top
- Blue Porcelain Oven Interior
- Heavy Duty Continuous Cast Iron Cooking Grates
- Automatic Re-Ignition Safety Feature
- Reverse Direction Commercial Convection Fan
- Two (2) Halogen Oven Interior Lights
- Thermostatically Controlled Oven Heating System
- CSA Certified ABS Control Knobs
- CSA Certified Unit

### BURNER PERFORMANCE

Total Number of Range Top Burners	4 Burners
Front Left Sealed Single Burner BTU	18,000
Front Right Sealed Single Burner BTU	18,000
Rear Left Sealed Dual Burner BTU	15,000
* Extra Low Simmer Function BTU	650
Rear Right Sealed Dual Burner BTU	15,000
* Extra Low Simmer Function BTU	650

### OVEN PERFORMANCE

Oven Capacity	4.2 cu. Ft.
U-Shaped Stove Burner BTU	22,000
Infrared Broil Burner BTU	16,500

### TECHNICAL DETAILS

Fuel Type	Natural Gas / LP (See Accessory)
Electrical Requirements	120V
Circuit Breaker (A)	15 or 20 A
Frequency (Hz)	60 Hz

### DIMENSION & WEIGHT

Product Dimension (W x D x H) (in)	29 <sup>15</sup> / <sub>16</sub> " x 26" x 35 <sup>1</sup> / <sub>2</sub> "
Required Cutout Size (W x D x H) (in)	30 <sup>1</sup> / <sub>8</sub> " x 24"-25" x 35 <sup>1</sup> / <sub>2</sub> "-36 <sup>1</sup> / <sub>2</sub> "
Product Net Weight	241 lbs.
Adjustable Range Legs	1"

### ACCESSORIES (NOT INCLUDED)

- Stainless Steel Island Trim
- Liquid propane Gas Conversion Kit
- High Altitude Conversion Kits for LP/Natural Gas

### WARRANTY

2 Year Warranty On Parts and Labor



# HRG3617U

## 36-Inch Professional Stainless Steel Gas Range with Griddle



### FEATURES

- Black Porcelain Drip Pan On Cook Top
- Blue Porcelain Oven Interior
- Thermostatically Controlled Griddle with Dishwasher Safe Drip Pan
- Heavy Duty Continuous Cast Iron Cooking Grates
- Automatic Re-Ignition Safety Feature
- Reverse Direction Commercial Convection Fan
- Two (2) Halogen Oven Interior Lights
- Thermostatically Controlled Oven Heating System
- CSA Certified ABS Control Knobs
- CSA Certified Unit

### GRIDDLE PERFORMANCE

Infrared Thermostatically Controlled Stainless Steel Griddle BTU	15,000
--	--------

### BURNER PERFORMANCE

Total Number of Range Top Burners	4 Burners
Front Left Sealed Single Burner BTU	18,000
Front Right Sealed Single Burner BTU	18,000
Rear Left Sealed Dual Burner BTU	15,000
* Extra Low Simmer Function BTU	650
Rear Right Sealed Dual Burner BTU	15,000
* Extra Low Simmer Function BTU	650

### OVEN PERFORMANCE

Oven Capacity	5.2 cu. Ft.
U-Shaped Stove Burner BTU	22,000
Infrared Broil Burner BTU	16,500

### TECHNICAL DETAILS

Fuel Type	Natural Gas / LP (See Accessory)
Electrical Requirements	120V
Circuit Breaker (A)	15 or 20 A
Frequency (Hz)	60 Hz

### DIMENSION & WEIGHT

Product Dimension (W x D x H) (in)	35 <sup>15</sup> / <sub>16</sub> " x 26" x 35 1/2"
Required Cutout Size (W x D x H) (in)	36 1/8" x 24"-25" x 35 1/2"-36 1/2"
Product Net Weight	290 lbs.
Adjustable Range Legs	1"

### ACCESSORIES (NOT INCLUDED)

- Stainless Steel Island Trim
- Liquid Propane Gas Conversion Kit
- High Altitude Conversion Kits for LP/Natural Gas

### WARRANTY

2 Year Warranty On Parts and Labor

# HRG3618U

## 36-Inch Professional Stainless Steel Gas Range



### FEATURES

- Black Porcelain Drip Pan On Cook Top
- Blue Porcelain Oven Interior
- Heavy Duty Continuous Cast Iron Cooking Grates
- Automatic Re-Ignition Safety Feature
- Reverse Direction Commercial Convection Fan
- Two (2) Halogen Oven Interior Lights
- Thermostatically Controlled Oven Heating System
- CSA Certified ABS Burner Control Knobs
- CSA Certified Unit

### BURNER PERFORMANCE

Total Number of Range Top Burners	6 Burners
Front Left Sealed Dual Burner BTU	15,000
* Extra Low Simmer Function BTU	650
Front Center Sealed Single Burner BTU	18,000
Front Right Sealed Dual Burner BTU	15,000
* Extra Low Simmer Function BTU	650
Rear Left Sealed Single Burner BTU	12,000
Rear Center Sealed Single Burner BTU	12,000
Rear Right Sealed Single Burner BTU	12,000

### OVEN PERFORMANCE

Oven Capacity	5.2 cu. Ft.
U-Shaped Stove Burner BTU	22,000
Infrared Broil Burner BTU	16,500

### TECHNICAL DETAILS

Fuel Type	Natural Gas / LP (See Accessory)
Electrical Requirements	120V
Circuit Breaker (A)	15 or 20 A
Frequency (Hz)	60 Hz

### DIMENSION & WEIGHT

Product Dimension (W x D x H) (in)	35 <sup>15</sup> / <sub>16</sub> " x 26" x 35 1/2"
Required Cutout Size (W x D x H) (in)	36 1/8" x 24"-25" x 35 1/2"-36 1/2"
Product Net Weight	281 lbs.
Adjustable Range Legs	1"

### ACCESSORIES (NOT INCLUDED)

- Stainless Steel Island Trim
- Liquid Propane Gas Conversion Kit
- High Altitude Conversion Kits for LP/Natural Gas

### WARRANTY

2 Year Warranty On Parts and Labor





# HRG4808U

## 48-Inch Professional Stainless Steel Gas Range with Griddle



### FEATURES

- Stainless Steel Range Top Drip Pan
- Blue Porcelain Oven Interior
- Thermostatically Controlled Griddle with Dishwasher Safe Drip Pan
- Heavy Duty Continuous Cast Iron Cooking Grates
- Automatic Re-Ignition Safety Feature
- Reverse Direction Commercial Convention Fan (30-inch Oven)
- Three (3) Halogen Oven Interior Lights
- Thermostatically Controlled Oven Heating System
- CSA Certified ABS Burner Control Knobs
- CSA Certified Unit

### GRIDDLE PERFORMANCE

Infrared Thermostatically Controlled Stainless Steel Griddle BTU	15,000
--	--------

### BURNER PERFORMANCE

Total Number of Range Top Burners	6 Burners
Front Left Sealed Single Burner BTU	18,000
Front Center Sealed Single Burner BTU	18,000
Front Right Sealed Single Burner BTU	18,000
Rear Left Sealed Dual Burner BTU	15,000
* Extra Low Simmer Function BTU	650
Rear Center Sealed Dual Burner BTU	15,000
* Extra Low Simmer Function BTU	650
Rear Right Sealed Dual Burner BTU	15,000
* Extra Low Simmer Function BTU	650

### 30" OVEN PERFORMANCE

Oven Capacity	4.2 cu. Ft.
U-Shaped Stove Burner BTU	22,000
Infrared Broil Burner BTU	16,500

### 18" OVEN PERFORMANCE

Oven Capacity	2.5 cu. Ft.
Oven Tube Burner BTU	14,000

### TECHNICAL DETAILS

Fuel Type	Natural Gas / LP (See Accessory)
Electrical Requirements	120V
Circuit Breaker (A)	15 or 20 A
Frequency (Hz)	60 Hz

### DIMENSION & WEIGHT

Product Dimension (W x D x H) (in)	47 7/8" x 26" x 35 1/2"
Required Cutout Size (W x D x H) (in)	48 1/8" x 24"-25" x 35 1/2"-36 1/2"
Product Net Weight	408 lbs.
Adjustable Range Legs	1"

### ACCESSORIES (NOT INCLUDED)

- Stainless Steel Island Trim
- Liquid Propane Gas Conversion Kit
- High Altitude Conversion Kits for LP/Natural Gas

### WARRANTY

2 Year Warranty On Parts and Labor



# HRD3088U

## 30-Inch Professional Stainless Steel Dual Fuel Range



### FEATURES

- Black Porcelain Drip Pan On Cook Top
- Black Porcelain Oven Interior
- Heavy Duty Continuous Cast Iron Cooking Grates
- Automatic Re-Ignition Safety Feature
- Reverse Direction Commercial Convection Fan
- Two (2) Halogen Oven Interior Lights
- Thermostatically Controlled Oven Heating System
- CSA Certified Metal Burner Control Knobs
- CSA Certified Unit

### BURNER PERFORMANCE

Total Number of Range Top Burners	4 Burners
Front Left Sealed Single Burner BTU	18,000
Front Right Sealed Dual Burner BTU	15,000
* Extra Low Simmer Function BTU	650
Rear Left Sealed Single Burner BTU	12,000
Rear Right Sealed Single Burner BTU	12,000

### OVEN PERFORMANCE

Oven Capacity	4.2 cu. Ft.
Bake Power	850 W(Top) 3,000 W (Bottom)
Broil Power	3,500 W

### TECHNICAL DETAILS

Fuel Type	Natural Gas / LP (See Accessory)
Electrical Requirements	240 V (14-50r Power Outlet Required)
Circuit Breaker (A)	30 A
Frequency (Hz)	60 Hz

### DIMENSION & WEIGHT

Product Dimension (W x D x H) (in)	29 <sup>15</sup> / <sub>16</sub> " x 26" x 35 <sup>1</sup> / <sub>2</sub> "
Required Cutout Size (W x D x H) (in)	30 <sup>1</sup> / <sub>8</sub> " x 24"-25" x 35 <sup>1</sup> / <sub>2</sub> "-36 <sup>1</sup> / <sub>2</sub> "
Product Net Weight	252 lbs.
Adjustable Range Legs	1"

### ACCESSORIES (NOT INCLUDED)

- Stainless Steel Island Trim
- Liquid Propane Gas Conversion Kit
- High Altitude Conversion Kits for LP/Natural Gas

### WARRANTY

2 Year Warranty On Parts and Labor

# HRD3606U

## 36-Inch Professional Stainless Steel Dual Fuel Range



### FEATURES

- Black Porcelain Drip Pan On Cook Top
- Black Porcelain Oven Interior
- Heavy Duty Continuous Cast Iron Cooking Grates
- Automatic Re-Ignition Safety Feature
- Reverse Direction Commercial Convection Fan
- Two (2) Halogen Oven Interior Lights
- Thermostatically Controlled Oven Heating System
- CSA Certified Metal Burner Control Knobs
- CSA Certified Unit

### BURNER PERFORMANCE

Total Number of Range Top Burners	6 Burners
Front Left Sealed Single Burner BTU	18,000
Front Center Sealed Single Burner BTU	18,000
Front Right Sealed Single Burner BTU	18,000
Rear Left Sealed Dual Burner BTU	15,000
* Extra Low Simmer Function BTU	650
Rear Center Sealed Single Burner BTU	12,000
Rear Right Sealed Dual Burner BTU	15,000
* Extra Low Simmer Function BTU	650

### OVEN PERFORMANCE

Oven Capacity	5.2 cu. Ft.
Bake Power	850 W(Top) 3,000 W (Bottom)
Broil Power	3,500 W

### TECHNICAL DETAILS

Fuel Type	Natural Gas / LP (See Accessory)
Electrical Requirements	240 V (14-50r Power Outlet Required)
Circuit Breaker (A)	30 A
Frequency (Hz)	60 Hz

### DIMENSION & WEIGHT

Product Dimension (W x D x H) (in)	35 <sup>15</sup> / <sub>16</sub> " x 26" x 35 1/2"
Required Cutout Size (W x D x H) (in)	36 1/8" x 24"-25" x 35 1/2"-36 1/2"
Product Net Weight	284 lbs.
Adjustable Range Legs	1"

### ACCESSORIES (NOT INCLUDED)

- Stainless Steel Island Trim
- Liquid Propane Gas Conversion Kit
- High Altitude Conversion Kits for LP/Natural Gas

### WARRANTY

2 Year Warranty On Parts and Labor



# HRD4803U

## 48-Inch Professional Stainless Steel Dual Fuel Range with Griddle



### FEATURES

- Stainless Steel Drip Pan On Cook Top
- Black Porcelain Oven Interior
- Thermostatically Controlled Griddle with Dishwasher Safe Drip Pan
- Heavy Duty Continuous Cast Iron Cooking Grates
- Automatic Re-Ignition Safety Feature
- Reverse Direction Commercial Convention Fan (30-inch Oven)
- Three (3) Halogen Oven Interior Lights
- Thermostatically Controlled Oven Heating System
- CSA Certified Metal Burner Control Knobs
- CSA Certified Unit

### GRIDDLE PERFORMANCE

Stainless Steel Griddle BTU	15,000
-----------------------------	--------

### BURNER PERFORMANCE

Total Number of Range Top Burners	6 Burners
Front Left Sealed Single Burner BTU	18,000
Front Center Sealed Dual Burner BTU	15,000
* Extra Low Simmer Function BTU	650
Front Right Sealed Single Burner BTU	18,000
Rear Left Sealed Single Burner BTU	12,000
Rear Center Sealed Single Burner BTU	12,000
Rear Right Sealed Dual Burner BTU	15,000
* Extra Low Simmer Function BTU	650

### 30" OVEN PERFORMANCE

Oven Capacity	4.2 cu. Ft.
Bake Power	850 W(Top) 3,000 W (Bottom)
Broil Power	3,500 W

### 18" OVEN PERFORMANCE

Oven Capacity	2.5 cu. Ft.
Bake Power	2,500 W (Bottom)

### TECHNICAL DETAILS

Fuel Type	Natural Gas / LP (See Accessory)
Electrical Requirements	240 V (14-50r Power Outlet Required)
Circuit Breaker (A)	40 A
Frequency (Hz)	60 Hz

### DIMENSION & WEIGHT

Product Dimension (W x D x H) (in)	47 7/8" x 26" x 35 1/2"
Required Cutout Size (W x D x H) (in)	48 1/8" x 24"-25" x 35 1/2"-36 1/2"
Product Net Weight	416 lbs.
Adjustable Range Legs	1"

### ACCESSORIES (NOT INCLUDED)

- Stainless Steel Island Trim
- Liquid Propane Gas Conversion Kit
- High Altitude Conversion Kits for LP/Natural Gas

### WARRANTY

2 Year Warranty On Parts and Labor



# HRT3003U

## 30-Inch Pro Style Stainless Steel Gas Range Top



### FEATURES

- Black Porcelain Drip Pan On Cook Top
- Heavy Duty Continuous Cast Iron Cooking Grates
- Automatic Re-Ignition Safety Feature
- CSA Certified ABS Controller Knobs

### BURNER PERFORMANCE

Total Number of Range Top Burners	4 Burners
Front Left & Right Sealed Single Burners	18,000 BTU
Rear Left & Right Sealed Single Burners	12,000 BTU

### TECHNICAL DETAILS

Fuel Type	Natural Gas / LP (See Accessory)
Electrical Requirements	120V
Circuit Breaker (A)	15 or 20 A
Frequency (Hz)	60 Hz

### DIMENSION & WEIGHT

Product Dimension (W x D x H) (in)	29 7/8 x 25 3/4 x 7 3/8"
Required Cutout Size (W x D x H) (in)	30 1/8" x 24" x 7 3/8"-7 7/8"
Product Net Weight	70 lbs.
Adjustable Range Legs	1/2"

### ACCESSORIES (NOT INCLUDED)

- Liquid propane Gas Conversion Kit
- High Altitude Conversion Kits for LP/Natural Gas

### WARRANTY

2 Year Warranty On Parts and Labor

# HRT3618U

## 36-Inch Pro Style Stainless Steel Gas Range Top



### FEATURES

- Black Porcelain Drip Pan On Cook Top
- Heavy Duty Continuous Cast Iron Cooking Grates
- Automatic Re-Ignition Safety Feature
- CSA Certified ABS Controller Knobs

### BURNER PERFORMANCE

Total Number of Range Top Burners	6 Burners
Front Left & Right Sealed Dual Burners	15,000 BTU
* Extra Low Simmer Function	650 BTU
Front Center Sealed Single Burner	18,000 BTU
Rear Sealed Single Burners (All Three)	12,000 BTU

### TECHNICAL DETAILS

Fuel Type	Natural Gas / LP (See Accessory)
Electrical Requirements	120V
Circuit Breaker (A)	15 or 20 A
Frequency (Hz)	60 Hz

### DIMENSION & WEIGHT

Product Dimension (W x D x H) (in)	36" x 25 3/4" x 7 3/8"
Required Cutout Size (W x D x H) (in)	36 1/4" x 24" x 7 3/8"-7 7/8"
Product Net Weight	85 lbs.
Adjustable Range Legs	1/2"

### ACCESSORIES (NOT INCLUDED)

- Liquid propane Gas Conversion Kit
- High Altitude Conversion Kits for LP/Natural Gas

### WARRANTY

2 Year Warranty On Parts and Labor



# 04 SERIES RANGE HOOD

## Pro Style Stainless Steel Wall Chimney Range Hood



**FEATURES**

<b>Controls</b>	4 Speed Fan LCD Touch Control Buttons
<b>Installation Type</b>	Ducted (Top)
<b>Illumination</b>	<b>30" / 36"</b> Two (2) 1.5W Long Life LED Lamps
<b>Blower</b>	<b>30" / 36"</b> 700 CFM One (1) 6 7/8" Round Duct
<b>Filter Type</b>	Baffle Filters / Stainless Steel / Dishwasher Safe
<b>Special Function</b>	1-15 Minutes Programmed Auto Shut-Off
<b>Remote Control</b>	One (1) Remote Control Included

**SPECIFICATION**

<b>Size</b>	30", 36"
<b>Models</b>	HRH3004U 29 1/2" x 21 5/8" x 2 5/16"
(W x D x H) (in)	HRH3604U 35 1/2" x 21 5/8" x 2 5/16"
<b>Type / Finish</b>	Wall Chimney Range Hood / Stainless Steel
<b>Duct Covers</b>	Two (2) Adjustable Cover
(W x D x H) (in)	13 1/8" x 13" x 19 11/16"
<b>Electrical</b>	15 Amps at 120 Volts
<b>Certification</b>	CSA Certified
<b>Warranty</b>	2 Year Limited Warranty

# 05 SERIES RANGE HOOD

## Pro Style Stainless Steel Under Cabinet Range Hood



**FEATURES**

<b>Controls</b>	3 Speed Fan Touch Control Buttons
<b>Installation Type</b>	Ducted (Top)
<b>Illumination</b>	<b>30" / 36"</b> Two (2) 1.5W Long Life LED Lamps
	<b>48"</b> Three (3) 1.5W Long Life LED Lamps
<b>Blower</b>	<b>30" / 36"</b> 900 CFM One (1) 7 5/8" Round Duct
	<b>48"</b> 1,200 CFM Two (2) 7 5/8" Round Duct
<b>Filter Type</b>	Baffle Filters / Stainless Steel / Dishwasher Safe
<b>Special Function</b>	15 Minutes Pre-Programmed Auto Shut-Off

**SPECIFICATION**

<b>Size</b>	30", 36", 48"
<b>Models</b>	HRH3005U 29 3/4" x 23 3/8" x 18"
(W x D x H) (in)	HRH3605U 35 3/4" x 23 3/8" x 18"
	HRH4805U 47 3/4" x 23 3/8" x 18"
<b>Type / Finish</b>	Under Cabinet Range Hood / Stainless Steel
<b>Electrical</b>	15 Amps at 120 Volts
<b>Certification</b>	CSA Certified
<b>Warranty</b>	2 Year Limited Warranty

# 06 SERIES RANGE HOOD

Pro Style Stainless Steel Under Cabinet Range Hood with Anti-Fingerprint Finish



**FEATURES**

<b>Controls</b>	3 Speed Fan Touch Control Buttons	
<b>Installation Type</b>	Ducted (Top)	
<b>Illumination</b>	<b>30" / 36"</b>	Two (2) 1.5W Long Life LED Lamps
	<b>48"</b>	Three (3) 1.5W Long Life LED Lamps
<b>Blower</b>	<b>30" / 36"</b>	900 CFM    One (1) 6 7/8" Round Duct
	<b>48"</b>	900 CFM    Two (2) 6 7/8" Round Duct
<b>Filter Type</b>	Baffle Filters / Stainless Steel / Dishwasher Safe	
<b>Special Function</b>	15 Minutes Pre-Programmed Auto Shut-Off	

**SPECIFICATION**

<b>Size</b>	30", 36", 48"	
<b>Models</b>	<b>HRH3006U</b>	29 3/4"(W) x 21 5/8"(D) x 9 7/8"(H)
	<b>HRH3606U</b>	35 3/4"(W) x 21 5/8"(D) x 9 7/8"(H)
	<b>HRH4806U</b>	47 3/4"(W) x 21 5/8"(D) x 9 7/8"(H)
<b>Type / Finish</b>	Under Cabinet Range Hood / Stainless Steel Anti-Fingerprint with Luster	
<b>Electrical</b>	15 Amps at 120 Volts	
<b>Certification</b>	CSA Certified	
<b>Warranty</b>	2 Year Limited Warranty	

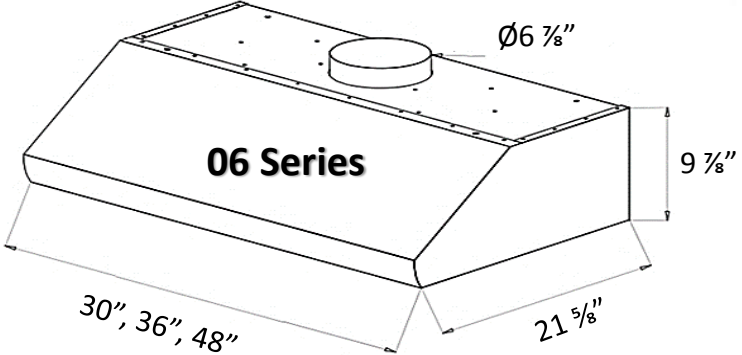
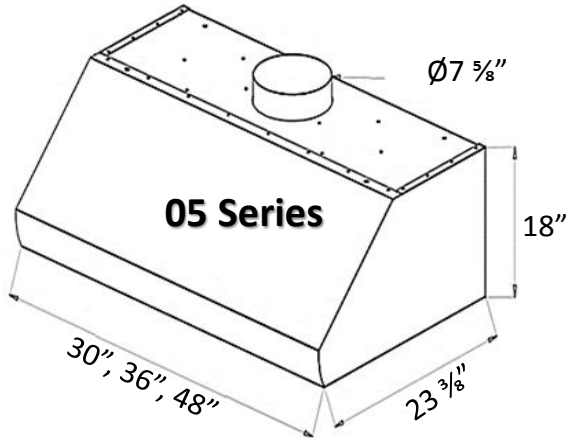
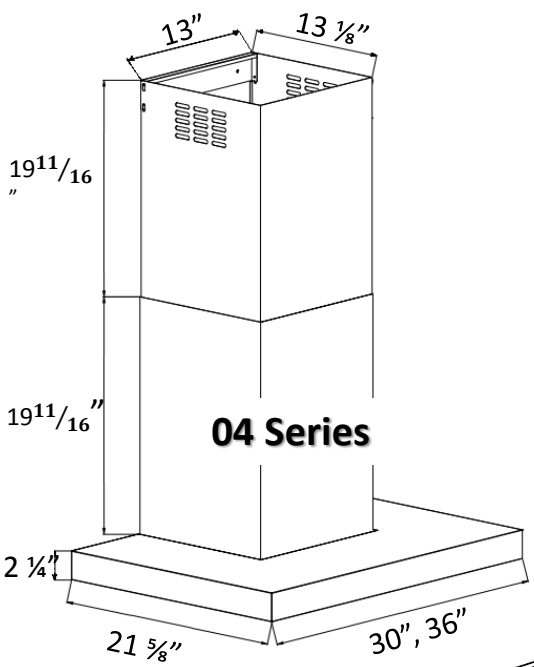

# HDW2401SS

## 24" Pro Style Stainless Steel Dishwasher



**Features:**

- Delayed Start** (Pre-Programmed 1 - 24 hrs)
- Multiple Filter System** (Save water and energy with optimal performance)
- Smart Wash System** (Soil Sensor to help determine the cycle)
- Four Spray Arms**
- Removable Utensil Basket**
- Detergent & Rinse Aid Dispenser**

**Specification:**

<b>Size</b>	24 inch Semi-built In Style
<b>Noise Level</b>	45db
<b>Load Capacity</b>	48PCS / 20GP
<b>Product Dimension (W x D x H) (in)</b>	24" x 24 1/2" x 33 1/2"
<b>Product Weight</b>	91lb (41kg)
<b>Power Supply</b>	120volts, 60Hz
<b>Rated Power Usage</b>	Wash motor 95W Heater 840W
<b>Power of Heating Element</b>	120V / 840W
<b>Inlet Water Temperature Minimum</b>	120°F (49°C)
<b>Water Feed Pressure</b>	20 ~ 120 psi (138~ 828kPa)
<b>System Outlet Hose Length</b>	59"
<b>Washing Performance</b>	80 Plus Certified
<b>Water Consumption</b>	≤ 13.31L (3.1gal)
<b>Warranty</b>	2 Year Limited Warranty
<b>Energy Saving Class At A++</b>	CSA Certificated



# JC-116A2EQ

## Dual Zone 36 Bottle Wine Cooler



### Features

- |  |  |
|--|--|
| Dual Temperature Zone Design           | 40°F - 65°F / 40°F - 65°F                  |
| Stainless Steel Door and Handle        | White LED Interior Lights With Switch      |
| Twelve (12) Chromed Metal Wine Racks   | Blue LED Temperature Display (°C / °F)     |
| Built-In or Freestanding Application   | Blue LED Touch Pad Digital Control Readout |
| Tempered/Smoked Double Pane Glass Door |  |

### Specifications

- |  |                                   |
|--|-----------------------------------|
| Model: JC-116A2EQ  | Compressor-Powered Cooling        |
| Brand: Thor Kitchen  | Two (2) Interior Fans             |
| Capacity: 36 Bottle  | Refrigerant: R134a                |
| Input Voltage: 115V/60Hz   | 100% HFC Free & FCKW (CFC) Free   |
| Product Weight: 121 lbs.   | Energy Efficient Design           |
| CE, ETL, CB, RoHS Certified                                      | Warranty: 2 Year Limited Warranty |
| Product Dimension (W x D x H) (in): 23 1/2" x 22 1/2" x 32 5/16" |                                   |

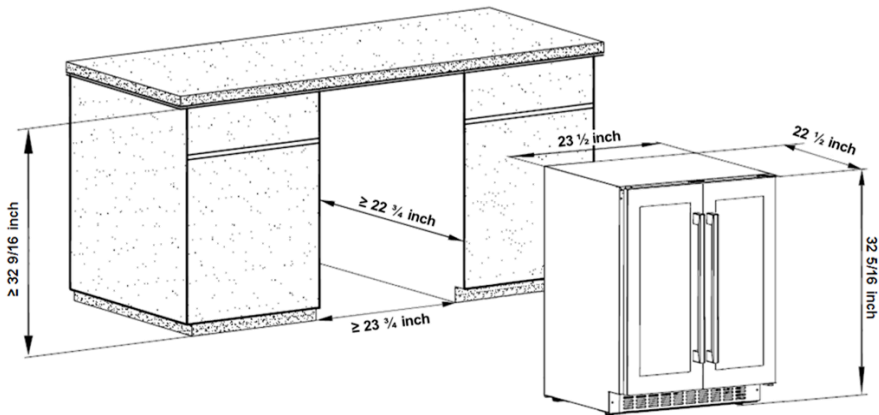
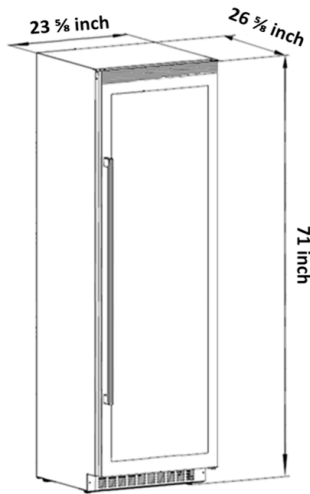

# JC-428B2EQ

## Dual Zone 156 Bottle Wine Cooler



### Features

- |   |  |
|---|--|
| Dual Temperature Zone Design                | 40°F - 65°F / 40°F - 65°F                  |
| Reversible Door                             | White LED Interior Lights with Switch      |
| 15 Roll-Out Wooden Racks With Aluminum Trim | Blue LED Temperature Display               |
| Built-In or Freestanding Application        | Blue LED Touch Pad Digital Control Readout |
| Tempered/Smoked Double Pane Glass Door      | Stainless steel door and handle            |
| Built-In Lock For Extra Security            |  |

### Specifications

- |   |                                   |
|---|-----------------------------------|
| Model: JC-428B2EQ   | Compressor-Powered Cooling        |
| Brand: Thor Kitchen   | Two (2) Interior Fans             |
| Capacity: 156 Bottle  | Refrigerant: R134a                |
| Input Voltage: 115V/60Hz                                    | 100% HFC & FCKW (CFC) Free        |
| Weight: 231 lbs.  | Energy Efficient Design           |
| CE, ETL, CB, RoHS Certified                                 | Warranty: 2 Year Limited Warranty |
| Product Dimension (W x D x H) (in): 23 5/8" x 26 3/8" x 71" |                                   |



# LRG3001U

## 30-Inch Professional Stainless Steel Gas Range

GAS RANGES 17



### FEATURES

- Black Porcelain Drip Pan On Cook Top
- Black Porcelain Oven Interior
- Heavy Duty Continuous Cast Iron Cooking Grates
- Convection Fan
- Two (2) Halogen Oven Interior Lights
- Thermostatically Controlled Oven Heating System
- CSA Certified ABS Black Control Knobs

### BURNER PERFORMANCE

Total Number of Range Top Burners	5 Burners
Left Front	18,000
Left Rear	4,000
Center (Oval)	9,000
Right Front	8,000
Right Rear	6,000

### OVEN PERFORMANCE

Oven Capacity	4.55 Cu. Ft.
Tube Stove Burner BTU	18,000
Oven Broil Burner BTU	10,000

### TECHNICAL DETAILS

Fuel Type	Natural Gas / LP (See Accessory)
Electrical Requirements	120V
Circuit Breaker (A)	15 or 20 A
Frequency (Hz)	60 Hz

### DIMENSION & WEIGHT

Product Dimension (W x D x H) (in)	30" x 26" x 35 1/2"
Required Cutout Size (W x D x H) (in)	30 1/8" x 24"-25" x 35 1/2"-36 1/2"
Product Net Weight	200 lbs.

### ACCESSORIES (NOT INCLUDED)

- Liquid Propane Gas Conversion Kit
- High Altitude Conversion Kits for LP/Natural Gas

### WARRANTY

2 Year Warranty On Parts and Labor

**HRF3601F**

## 36 in. 4 Door Counter Depth French Door Freestanding Refrigerator with Automatic Ice Maker

**CAPACITY**

Total Unit Gross Capacity	20.85 cu. ft.
Refrigerator Gross Capacity	15.16 cu. ft.
Freezer Gross Capacity	5.69 cu. ft.

**FEATURES**

Counter Depth French Door  
 2-Drawer Freezer Provides Better Organization  
 A Full-Width Chiller Drawer Provides Flexible Storage  
 Retractable Shelf Designed To Fit Taller Items With Ease  
 Dual Cycle and Dual Air-Cooled Refrigeration System  
 2 Large Humidity Controlled Fresh Food Drawers  
 Automatic Ice-Maker

**TECHNICAL DETAILS**

Rated Current (A)	2.7 A
Defrost Current (A)	3.5 A
Volts (V)	115 V
Frequency (Hz)	60 Hz
Plug Type	120V-3 Prong
Refrigerant	R134a, 6.35 oz.

**REFRIGERATOR**

Lighting	High-Efficiency LED
Number of Shelves - Refrigerator	5
Adjustable Shelves - Refrigerator	4 Half-Width
Shelf Material - Refrigerator	Tempered Glass
Type of Shelves - Refrigerator	Tempered Glass
Gallon Storage Bins	4
Humidity Control Drawer	2
Defrost Process Freezer	Automatic
Defrost Process Refrigerator	Frost-Free
Ice Maker	Yes
Water Filter	Yes

**Warranty**

2 year warranty on parts and labor

