



— BRINGING —
**LUXURY &
INNOVATION**
TO THE COMFORT OF
YOUR OWN
HOME



1-877-288-8099

www.thorkitchen.com | info@thorgroup.us





Thor Kitchen is proud to offer you the experience to cook food like a true chef with our professional style appliances. With innovation, quality and performance, we can help you build a dream kitchen that brings excitement to your home.



STANDARDIZED QUALITY

- Every Thor Kitchen product is **CSA** certified.
- Wine coolers are **Intertek (ETL)** certified.
- Thor Kitchen ensures that every product is manufactured with 8 different safety and quality standard tests.
- We aim to provide affordable, professional style appliances to the general public. We want to give you an enjoyable cooking experience with our products.

KEY RANGE PARTS & FEATURES



HEAVY DUTY CONTINUOUS GRATES

Each grate is one single piece that can handle any size of cookware



GAS VALVE IS SOURCED FROM SPAIN



15,000 BTU SEALED DUAL BURNER

Powerful dual burner with Extra Low 650 BTU Simmer Function

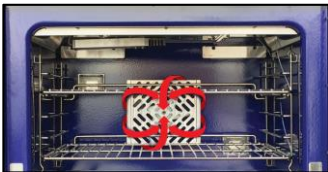

BLUE PORCELAIN OVEN INTERIOR

Adding beauty & pleasure to your baking experience

Reverse Direction Convention Fan Provides controlled heat distribution for delicate baking

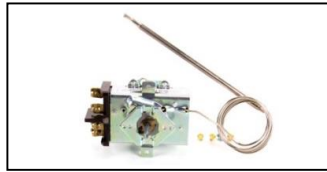

USA MADE THERMOSTATS



18,000 BTU SEALED SINGLE BURNER

A high powered burner designed to accommodate even the largest cookware

Automatic Re-Ignition if the burner flame extinguishes



HEAVY DUTY HANDLE

For professional style and functionality

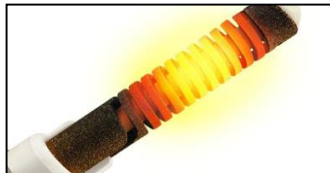

USA MADE SURFACE IGNITOR



INFRARED BROIL BURNER

High-End broiler radiates the heat to sear your food & seal in the juices

HRG3080U

30-Inch Professional Stainless Steel Gas Range



FEATURES

- Black Porcelain Drip Pan On Cook Top
- Blue Porcelain Oven Interior
- Heavy Duty Continuous Cast Iron Cooking Grates
- Automatic Re-Ignition Safety Feature
- Reverse Direction Commercial Convection Fan
- Two (2) Halogen Oven Interior Lights
- Thermostatically Controlled Oven Heating System
- CSA Certified ABS Control Knobs
- CSA Certified Unit

BURNER PERFORMANCE

Total Number of Range Top Burners	4 Burners
Front Left Sealed Single Burner BTU	18,000
Front Right Sealed Dual Burner BTU	15,000
* Extra Low Simmer Function BTU	650
Rear Left Sealed Single Burner BTU	12,000
Rear Right Sealed Single Burner BTU	12,000

OVEN PERFORMANCE

Oven Capacity	4.2 Cu. Ft.
U-Shaped Stove Burner BTU	22,000
Oven Broil Burner BTU	13,000

TECHNICAL DETAILS

Fuel Type	Natural Gas / LP (See Accessory)
Electrical Requirements	120V
Circuit Breaker (A)	15 or 20 A
Frequency (Hz)	60 Hz

DIMENSION & WEIGHT

Product Dimension (W x D x H) (in)	29 15/16" x 26" x 35 1/2"
Required Cutout Size (W x D x H) (in)	30 1/8" x 24"-25" x 35 1/2"
Product Net Weight	200 lbs.

ACCESSORIES (NOT INCLUDED)

- Stainless Steel Island Trim
- Liquid Propane Gas Conversion Kit
- High Altitude Conversion Kits for LP/Natural Gas

WARRANTY

2 Year Warranty On Parts and Labor



HRG3026U

30-Inch Professional Stainless Steel Gas Range



FEATURES

- Black Porcelain Drip Pan On Cook Top
- Blue Porcelain Oven Interior
- Heavy Duty Continuous Cast Iron Cooking Grates
- Automatic Re-Ignition Safety Feature
- Reverse Direction Commercial Convection Fan
- Two (2) Halogen Oven Interior Lights
- Thermostatically Controlled Oven Heating System
- CSA Certified ABS Control Knobs
- CSA Certified Unit

BURNER PERFORMANCE

Total Number of Range Top Burners	4 Burners
Front Left Sealed Single Burner BTU	18,000
Front Right Sealed Single Burner BTU	18,000
Rear Left Sealed Dual Burner BTU	15,000
* Extra Low Simmer Function BTU	650
Rear Right Sealed Dual Burner BTU	15,000
* Extra Low Simmer Function BTU	650

OVEN PERFORMANCE

Oven Capacity	4.2 cu. Ft.
U-Shaped Stove Burner BTU	22,000
Infrared Broil Burner BTU	16,500

TECHNICAL DETAILS

Fuel Type	Natural Gas / LP (See Accessory)
Electrical Requirements	120V
Circuit Breaker (A)	15 or 20 A
Frequency (Hz)	60 Hz

DIMENSION & WEIGHT

Product Dimension (W x D x H) (in)	29 ¹⁵ / ₁₆ " x 26" x 35 ¹ / ₂ "
Required Cutout Size (W x D x H) (in)	30 ¹ / ₈ " x 24"-25" x 35 ¹ / ₂ "-36 ¹ / ₂ "
Product Net Weight	241 lbs.
Adjustable Range Legs	1"

ACCESSORIES (NOT INCLUDED)

- Stainless Steel Island Trim
- Liquid propane Gas Conversion Kit
- High Altitude Conversion Kits for LP/Natural Gas

WARRANTY

2 Year Warranty On Parts and Labor



HRG3617U

36-Inch Professional Stainless Steel Gas Range with Griddle



FEATURES

- Black Porcelain Drip Pan On Cook Top
- Blue Porcelain Oven Interior
- Thermostatically Controlled Griddle with Dishwasher Safe Drip Pan
- Heavy Duty Continuous Cast Iron Cooking Grates
- Automatic Re-Ignition Safety Feature
- Reverse Direction Commercial Convection Fan
- Two (2) Halogen Oven Interior Lights
- Thermostatically Controlled Oven Heating System
- CSA Certified ABS Control Knobs
- CSA Certified Unit

GRIDDLE PERFORMANCE

Infrared Thermostatically Controlled Stainless Steel Griddle BTU	15,000
--	--------

BURNER PERFORMANCE

Total Number of Range Top Burners	4 Burners
Front Left Sealed Single Burner BTU	18,000
Front Right Sealed Single Burner BTU	18,000
Rear Left Sealed Dual Burner BTU	15,000
* Extra Low Simmer Function BTU	650
Rear Right Sealed Dual Burner BTU	15,000
* Extra Low Simmer Function BTU	650

OVEN PERFORMANCE

Oven Capacity	5.2 cu. Ft.
U-Shaped Stove Burner BTU	22,000
Infrared Broil Burner BTU	16,500

TECHNICAL DETAILS

Fuel Type	Natural Gas / LP (See Accessory)
Electrical Requirements	120V
Circuit Breaker (A)	15 or 20 A
Frequency (Hz)	60 Hz

DIMENSION & WEIGHT

Product Dimension (W x D x H) (in)	35 ¹⁵ / ₁₆ " x 26" x 35 1/2"
Required Cutout Size (W x D x H) (in)	36 1/8" x 24"-25" x 35 1/2"-36 1/2"
Product Net Weight	290 lbs.
Adjustable Range Legs	1"

ACCESSORIES (NOT INCLUDED)

- Stainless Steel Island Trim
- Liquid Propane Gas Conversion Kit
- High Altitude Conversion Kits for LP/Natural Gas

WARRANTY

2 Year Warranty On Parts and Labor

HRG3618U

36-Inch Professional Stainless Steel Gas Range



FEATURES

- Black Porcelain Drip Pan On Cook Top
- Blue Porcelain Oven Interior
- Heavy Duty Continuous Cast Iron Cooking Grates
- Automatic Re-Ignition Safety Feature
- Reverse Direction Commercial Convection Fan
- Two (2) Halogen Oven Interior Lights
- Thermostatically Controlled Oven Heating System
- CSA Certified ABS Burner Control Knobs
- CSA Certified Unit

BURNER PERFORMANCE

Total Number of Range Top Burners	6 Burners
Front Left Sealed Dual Burner BTU	15,000
* Extra Low Simmer Function BTU	650
Front Center Sealed Single Burner BTU	18,000
Front Right Sealed Dual Burner BTU	15,000
* Extra Low Simmer Function BTU	650
Rear Left Sealed Single Burner BTU	12,000
Rear Center Sealed Single Burner BTU	12,000
Rear Right Sealed Single Burner BTU	12,000

OVEN PERFORMANCE

Oven Capacity	5.2 cu. Ft.
U-Shaped Stove Burner BTU	22,000
Infrared Broil Burner BTU	16,500

TECHNICAL DETAILS

Fuel Type	Natural Gas / LP (See Accessory)
Electrical Requirements	120V
Circuit Breaker (A)	15 or 20 A
Frequency (Hz)	60 Hz

DIMENSION & WEIGHT

Product Dimension (W x D x H) (in)	35 ¹⁵ / ₁₆ " x 26" x 35 1/2"
Required Cutout Size (W x D x H) (in)	36 1/8" x 24"-25" x 35 1/2"-36 1/2"
Product Net Weight	281 lbs.
Adjustable Range Legs	1"

ACCESSORIES (NOT INCLUDED)

- Stainless Steel Island Trim
- Liquid Propane Gas Conversion Kit
- High Altitude Conversion Kits for LP/Natural Gas

WARRANTY

2 Year Warranty On Parts and Labor



HRG4808U

48-Inch Professional Stainless Steel Gas Range with Griddle



FEATURES

- Stainless Steel Range Top Drip Pan
- Blue Porcelain Oven Interior
- Thermostatically Controlled Griddle with Dishwasher Safe Drip Pan
- Heavy Duty Continuous Cast Iron Cooking Grates
- Automatic Re-Ignition Safety Feature
- Reverse Direction Commercial Convention Fan (30-inch Oven)
- Three (3) Halogen Oven Interior Lights
- Thermostatically Controlled Oven Heating System
- CSA Certified ABS Burner Control Knobs
- CSA Certified Unit

GRIDDLE PERFORMANCE

Infrared Thermostatically Controlled Stainless Steel Griddle BTU	15,000
--	--------

BURNER PERFORMANCE

Total Number of Range Top Burners	6 Burners
Front Left Sealed Single Burner BTU	18,000
Front Center Sealed Single Burner BTU	18,000
Front Right Sealed Single Burner BTU	18,000
Rear Left Sealed Dual Burner BTU	15,000
* Extra Low Simmer Function BTU	650
Rear Center Sealed Dual Burner BTU	15,000
* Extra Low Simmer Function BTU	650
Rear Right Sealed Dual Burner BTU	15,000
* Extra Low Simmer Function BTU	650

30" OVEN PERFORMANCE

Oven Capacity	4.2 cu. Ft.
U-Shaped Stove Burner BTU	22,000
Infrared Broil Burner BTU	16,500

18" OVEN PERFORMANCE

Oven Capacity	2.5 cu. Ft.
Oven Tube Burner BTU	14,000

TECHNICAL DETAILS

Fuel Type	Natural Gas / LP (See Accessory)
Electrical Requirements	120V
Circuit Breaker (A)	15 or 20 A
Frequency (Hz)	60 Hz

DIMENSION & WEIGHT

Product Dimension (W x D x H) (in)	47 7/8" x 26" x 35 1/2"
Required Cutout Size (W x D x H) (in)	48 1/8" x 24"-25" x 35 1/2"-36 1/2"
Product Net Weight	408 lbs.
Adjustable Range Legs	1"

ACCESSORIES (NOT INCLUDED)

- Stainless Steel Island Trim
- Liquid Propane Gas Conversion Kit
- High Altitude Conversion Kits for LP/Natural Gas

WARRANTY

2 Year Warranty On Parts and Labor

HRD3088U

30-Inch Professional Stainless Steel Dual Fuel Range



FEATURES

- Black Porcelain Drip Pan On Cook Top
- Black Porcelain Oven Interior
- Heavy Duty Continuous Cast Iron Cooking Grates
- Automatic Re-Ignition Safety Feature
- Reverse Direction Commercial Convection Fan
- Two (2) Halogen Oven Interior Lights
- Thermostatically Controlled Oven Heating System
- CSA Certified Metal Burner Control Knobs
- CSA Certified Unit

BURNER PERFORMANCE

Total Number of Range Top Burners	4 Burners
Front Left Sealed Single Burner BTU	18,000
Front Right Sealed Dual Burner BTU	15,000
* Extra Low Simmer Function BTU	650
Rear Left Sealed Single Burner BTU	12,000
Rear Right Sealed Single Burner BTU	12,000

OVEN PERFORMANCE

Oven Capacity	4.2 cu. Ft.
Bake Power	850 W(Top) 3,000 W (Bottom)
Broil Power	3,500 W

TECHNICAL DETAILS

Fuel Type	Natural Gas / LP (See Accessory)
Electrical Requirements	240 V (14-50r Power Outlet Required)
Circuit Breaker (A)	30 A
Frequency (Hz)	60 Hz

DIMENSION & WEIGHT

Product Dimension (W x D x H) (in)	29 15/16" x 26" x 35 1/2"
Required Cutout Size (W x D x H) (in)	30 1/8" x 24"-25" x 35 1/2"-36 1/2"
Product Net Weight	252 lbs.
Adjustable Range Legs	1"

ACCESSORIES (NOT INCLUDED)

- Stainless Steel Island Trim
- Liquid Propane Gas Conversion Kit
- High Altitude Conversion Kits for LP/Natural Gas

WARRANTY

2 Year Warranty On Parts and Labor

HRD3606U

36-Inch Professional Stainless Steel

Dual Fuel Range



FEATURES

- Black Porcelain Drip Pan On Cook Top
- Black Porcelain Oven Interior
- Heavy Duty Continuous Cast Iron Cooking Grates
- Automatic Re-Ignition Safety Feature
- Reverse Direction Commercial Convection Fan
- Two (2) Halogen Oven Interior Lights
- Thermostatically Controlled Oven Heating System
- CSA Certified Metal Burner Control Knobs
- CSA Certified Unit

BURNER PERFORMANCE

Total Number of Range Top Burners	6 Burners
Front Left Sealed Single Burner BTU	18,000
Front Center Sealed Single Burner BTU	18,000
Front Right Sealed Single Burner BTU	18,000
Rear Left Sealed Dual Burner BTU	15,000
* Extra Low Simmer Function BTU	650
Rear Center Sealed Single Burner BTU	12,000
Rear Right Sealed Dual Burner BTU	15,000
* Extra Low Simmer Function BTU	650

OVEN PERFORMANCE

Oven Capacity	5.2 cu. Ft.
Bake Power	850 W(Top) 3,000 W (Bottom)
Broil Power	3,500 W

TECHNICAL DETAILS

Fuel Type	Natural Gas / LP (See Accessory)
Electrical Requirements	240 V (14-50r Power Outlet Required)
Circuit Breaker (A)	30 A
Frequency (Hz)	60 Hz

DIMENSION & WEIGHT

Product Dimension (W x D x H) (in)	35 ¹⁵ / ₁₆ " x 26" x 35 1/2"
Required Cutout Size (W x D x H) (in)	36 1/8" x 24"-25" x 35 1/2"-36 1/2"
Product Net Weight	284 lbs.
Adjustable Range Legs	1"

ACCESSORIES (NOT INCLUDED)

- Stainless Steel Island Trim
- Liquid Propane Gas Conversion Kit
- High Altitude Conversion Kits for LP/Natural Gas

WARRANTY

2 Year Warranty On Parts and Labor



HRD4803U

48-Inch Professional Stainless Steel Dual Fuel Range with Griddle



FEATURES

- Stainless Steel Drip Pan On Cook Top
- Black Porcelain Oven Interior
- Thermostatically Controlled Griddle with Dishwasher Safe Drip Pan
- Heavy Duty Continuous Cast Iron Cooking Grates
- Automatic Re-Ignition Safety Feature
- Reverse Direction Commercial Convention Fan (30-inch Oven)
- Three (3) Halogen Oven Interior Lights
- Thermostatically Controlled Oven Heating System
- CSA Certified Metal Burner Control Knobs
- CSA Certified Unit

GRIDDLE PERFORMANCE

Stainless Steel Griddle BTU 15,000

BURNER PERFORMANCE

Total Number of Range Top Burners 6 Burners
 Front Left Sealed Single Burner BTU 18,000
 Front Center Sealed Dual Burner BTU 15,000
 * Extra Low Simmer Function BTU 650
 Front Right Sealed Single Burner BTU 18,000
 Rear Left Sealed Single Burner BTU 12,000
 Rear Center Sealed Single Burner BTU 12,000
 Rear Right Sealed Dual Burner BTU 15,000
 * Extra Low Simmer Function BTU 650

30" OVEN PERFORMANCE

Oven Capacity 4.2 cu. Ft.
 Bake Power 850 W(Top)
 3,000 W (Bottom)
 Broil Power 3,500 W

18" OVEN PERFORMANCE

Oven Capacity 2.5 cu. Ft.
 Bake Power 2,500 W (Bottom)

TECHNICAL DETAILS

Fuel Type Natural Gas / LP (See Accessory)
 Electrical Requirements 240 V
 (14-50r Power Outlet Required)
 Circuit Breaker (A) 40 A
 Frequency (Hz) 60 Hz

DIMENSION & WEIGHT

Product Dimension (W x D x H) (in) 47 7/8" x 26" x 35 1/2"
 Required Cutout Size (W x D x H) (in) 48 1/8" x 24"-25" x 35 1/2"-36 1/2"
 Product Net Weight 416 lbs.
 Adjustable Range Legs 1"

ACCESSORIES (NOT INCLUDED)

- Stainless Steel Island Trim
- Liquid Propane Gas Conversion Kit
- High Altitude Conversion Kits for LP/Natural Gas

WARRANTY

2 Year Warranty On Parts and Labor

HRT3003U

30-Inch Pro Style Stainless Steel Gas Range Top



FEATURES

- Black Porcelain Drip Pan On Cook Top
- Heavy Duty Continuous Cast Iron Cooking Grates
- Automatic Re-Ignition Safety Feature
- CSA Certified ABS Controller Knobs

BURNER PERFORMANCE

Total Number of Range Top Burners	4 Burners
Front Left & Right Sealed Single Burners	18,000 BTU
Rear Left & Right Sealed Single Burners	12,000 BTU

TECHNICAL DETAILS

Fuel Type	Natural Gas / LP (See Accessory)
Electrical Requirements	120V
Circuit Breaker (A)	15 or 20 A
Frequency (Hz)	60 Hz

DIMENSION & WEIGHT

Product Dimension (W x D x H) (in)	29 7/8" x 25 3/4" x 7 3/8"
Required Cutout Size (W x D x H) (in)	30 1/8" x 24" x 7 3/8"-7 7/8"
Product Net Weight	70 lbs.
Adjustable Range Legs	1/2"

ACCESSORIES (NOT INCLUDED)

- Liquid propane Gas Conversion Kit
- High Altitude Conversion Kits for LP/Natural Gas

WARRANTY

2 Year Warranty On Parts and Labor

HRT3618U

36-Inch Pro Style Stainless Steel Gas Range Top



FEATURES

- Black Porcelain Drip Pan On Cook Top
- Heavy Duty Continuous Cast Iron Cooking Grates
- Automatic Re-Ignition Safety Feature
- CSA Certified ABS Controller Knobs

BURNER PERFORMANCE

Total Number of Range Top Burners	6 Burners
Front Left & Right Sealed Dual Burners	15,000 BTU
* Extra Low Simmer Function	650 BTU
Front Center Sealed Single Burner	18,000 BTU
Rear Sealed Single Burners (All Three)	12,000 BTU

TECHNICAL DETAILS

Fuel Type	Natural Gas / LP (See Accessory)
Electrical Requirements	120V
Circuit Breaker (A)	15 or 20 A
Frequency (Hz)	60 Hz

DIMENSION & WEIGHT

Product Dimension (W x D x H) (in)	36" x 25 3/4" x 7 3/8"
Required Cutout Size (W x D x H) (in)	36 1/4" x 24" x 7 3/8"-7 7/8"
Product Net Weight	85 lbs.
Adjustable Range Legs	1/2"

ACCESSORIES (NOT INCLUDED)

- Liquid propane Gas Conversion Kit
- High Altitude Conversion Kits for LP/Natural Gas

WARRANTY

2 Year Warranty On Parts and Labor

04 SERIES RANGE HOOD

Pro Style Stainless Steel Wall Chimney Range Hood



FEATURES

Controls	4 Speed Fan LCD Touch Control Buttons		
Installation Type	Ducted (Top)		
Illumination	30" / 36"	Two (2) 1.5W Long Life LED Lamps	
Blower	30" / 36"	700 CFM	One (1) 6 7/8" Round Duct
Filter Type	Baffle Filters / Stainless Steel / Dishwasher Safe		
Special Function	1-15 Minutes Programmed Auto Shut-Off		
Remote Control	One (1) Remote Control Included		

SPECIFICATION

Size	30", 36"		
Models	HRH3004U	29 1/2" x 21 5/8" x 2 5/16"	
(W x D x H) (in)	HRH3604U	35 1/2" x 21 5/8" x 2 5/16"	
Type / Finish	Wall Chimney Range Hood / Stainless Steel		
Duct Covers	Two (2) Adjustable Cover		
(W x D x H) (in)	13 1/8" x 13" x 19 11/16"		
Electrical	15 Amps at 120 Volts		
Certification	CSA Certified		
Warranty	2 Year Limited Warranty		

05 SERIES RANGE HOOD

Pro Style Stainless Steel Under Cabinet Range Hood



FEATURES

Controls	3 Speed Fan Touch Control Buttons		
Installation Type	Ducted (Top)		
Illumination	30" / 36"	Two (2) 1.5W Long Life LED Lamps	
	48"	Three (3) 1.5W Long Life LED Lamps	
Blower	30" / 36"	900 CFM	One (1) 7 5/8" Round Duct
	48"	1,200 CFM	Two (2) 7 5/8" Round Duct
Filter Type	Baffle Filters / Stainless Steel / Dishwasher Safe		
Special Function	15 Minutes Pre-Programmed Auto Shut-Off		

SPECIFICATION

Size	30", 36", 48"		
Models	HRH3005U	29 3/4" x 23 3/8" x 18"	
(W x D x H) (in)	HRH3605U	35 3/4" x 23 3/8" x 18"	
	HRH4805U	47 3/4" x 23 3/8" x 18"	
Type / Finish	Under Cabinet Range Hood / Stainless Steel		
Electrical	15 Amps at 120 Volts		
Certification	CSA Certified		
Warranty	2 Year Limited Warranty		

06 SERIES RANGE HOOD

Pro Style Stainless Steel Under Cabinet Range Hood with Anti-Fingerprint Finish



FEATURES

Controls	3 Speed Fan Touch Control Buttons	
Installation Type	Ducted (Top)	
Illumination	30" / 36"	Two (2) 1.5W Long Life LED Lamps
	48"	Three (3) 1.5W Long Life LED Lamps
Blower	30" / 36"	900 CFM One (1) 6 7/8" Round Duct
	48"	900 CFM Two (2) 6 7/8" Round Duct
Filter Type	Baffle Filters / Stainless Steel / Dishwasher Safe	
Special Function	15 Minutes Pre-Programmed Auto Shut-Off	

SPECIFICATION

Size	30", 36", 48"	
Models	HRH3006U	29 3/4"(W) x 21 5/8"(D) x 9 7/8"(H)
	HRH3606U	35 3/4"(W) x 21 5/8"(D) x 9 7/8"(H)
	HRH4806U	47 3/4"(W) x 21 5/8"(D) x 9 7/8"(H)
Type / Finish	Under Cabinet Range Hood / Stainless Steel Anti-Fingerprint with Luster	
Electrical	15 Amps at 120 Volts	
Certification	CSA Certified	
Warranty	2 Year Limited Warranty	

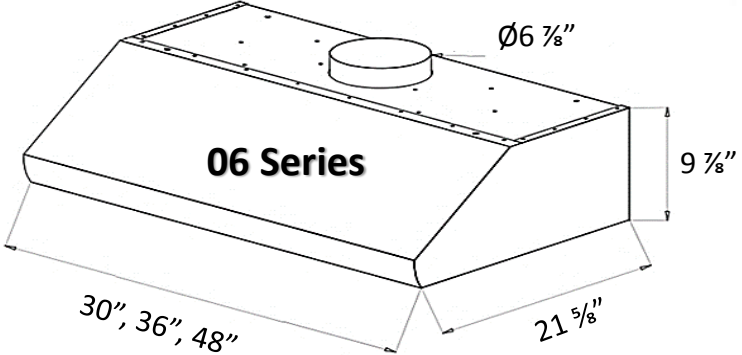
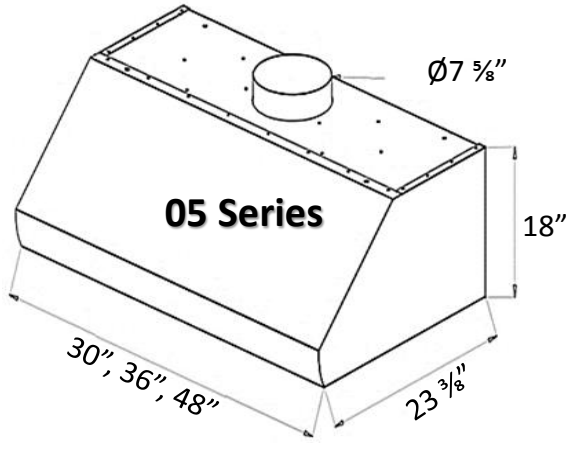
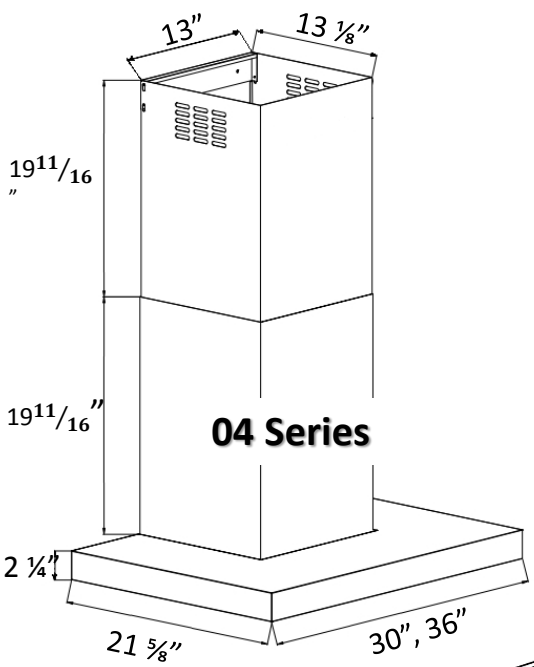

HDW2401SS

24" Pro Style Stainless Steel Dishwasher



Features:

- Delayed Start** (Pre-Programmed 1 - 24 hrs)
- Multiple Filter System** (Save water and energy with optimal performance)
- Smart Wash System** (Soil Sensor to help determine the cycle)
- Four Spray Arms**
- Removable Utensil Basket**
- Detergent & Rinse Aid Dispenser**

Specification:

Size	24 inch Semi-built In Style
Noise Level	45db
Load Capacity	48PCS / 20GP
Product Dimension (W x D x H) (in)	24" x 24 1/2" x 33 1/2"
Product Weight	91lb (41kg)
Power Supply	120volts, 60Hz
Rated Power Usage	Wash motor 95W Heater 840W
Power of Heating Element	120V / 840W
Inlet Water Temperature Minimum	120°F (49°C)
Water Feed Pressure	20 ~ 120 psi (138~ 828kPa)
System Outlet Hose Length	59"
Washing Performance	80 Plus Certified
Water Consumption	≤ 13.31L (3.1gal)
Warranty	2 Year Limited Warranty
Energy Saving Class At A++	CSA Certificated



JC-116A2EQ

Dual Zone 36 Bottle Wine Cooler



Features

- | | |
|--|--|
| Dual Temperature Zone Design | 40°F - 65°F / 40°F - 65°F |
| Stainless Steel Door and Handle | White LED Interior Lights With Switch |
| Twelve (12) Chromed Metal Wine Racks | Blue LED Temperature Display (°C / °F) |
| Built-In or Freestanding Application | Blue LED Touch Pad Digital Control Readout |
| Tempered/Smoked Double Pane Glass Door | |

Specifications

- | | |
|--|-----------------------------------|
| Model: JC-116A2EQ | Compressor-Powered Cooling |
| Brand: Thor Kitchen | Two (2) Interior Fans |
| Capacity: 36 Bottle | Refrigerant: R134a |
| Input Voltage: 115V/60Hz | 100% HFC Free & FCKW (CFC) Free |
| Product Weight: 121 lbs. | Energy Efficient Design |
| CE, ETL, CB, RoHS Certified | Warranty: 2 Year Limited Warranty |
| Product Dimension (W x D x H) (in): 23 1/2" x 22 1/2" x 32 5/16" | |

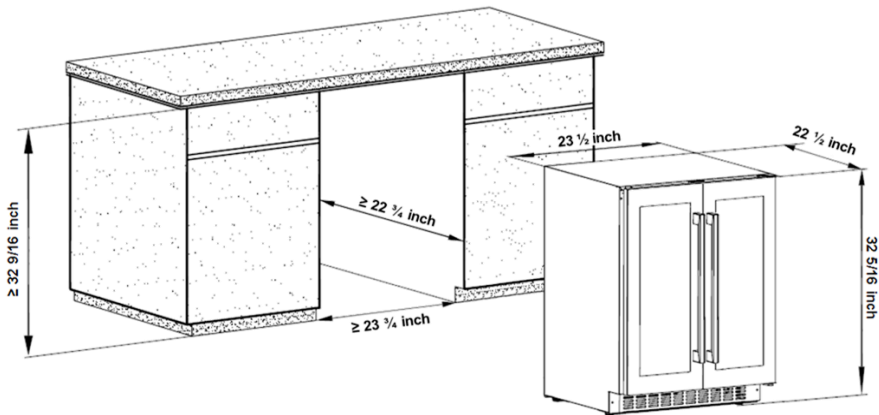
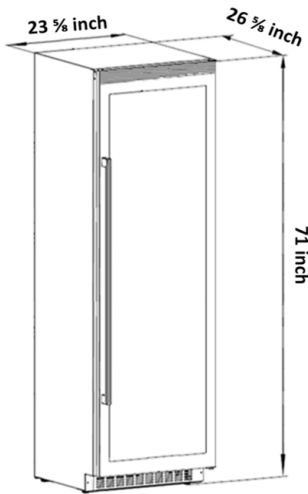

JC-428B2EQ

Dual Zone 156 Bottle Wine Cooler



Features

- | | |
|---|--|
| Dual Temperature Zone Design | 40°F - 65°F / 40°F - 65°F |
| Reversible Door | White LED Interior Lights with Switch |
| 15 Roll-Out Wooden Racks With Aluminum Trim | Blue LED Temperature Display |
| Built-In or Freestanding Application | Blue LED Touch Pad Digital Control Readout |
| Tempered/Smoked Double Pane Glass Door | Stainless steel door and handle |
| Built-In Lock For Extra Security | |

Specifications

- | | |
|---|-----------------------------------|
| Model: JC-428B2EQ | Compressor-Powered Cooling |
| Brand: Thor Kitchen | Two (2) Interior Fans |
| Capacity: 156 Bottle | Refrigerant: R134a |
| Input Voltage: 115V/60Hz | 100% HFC & FCKW (CFC) Free |
| Weight: 231 lbs. | Energy Efficient Design |
| CE, ETL, CB, RoHS Certified | Warranty: 2 Year Limited Warranty |
| Product Dimension (W x D x H) (in): 23 5/8" x 26 5/8" x 71" | |

LRG3001U

30-Inch Professional Stainless Steel Gas Range

GAS RANGES 17



FEATURES

- Black Porcelain Drip Pan On Cook Top
- Black Porcelain Oven Interior
- Heavy Duty Continuous Cast Iron Cooking Grates
- Convection Fan
- Two (2) Halogen Oven Interior Lights
- Thermostatically Controlled Oven Heating System
- CSA Certified ABS Black Control Knobs

BURNER PERFORMANCE

Total Number of Range Top Burners	5 Burners
Left Front	18,000
Left Rear	4,000
Center (Oval)	9,000
Right Front	8,000
Right Rear	6,000

OVEN PERFORMANCE

Oven Capacity	4.55 Cu. Ft.
Tube Stove Burner BTU	18,000
Oven Broil Burner BTU	10,000

TECHNICAL DETAILS

Fuel Type	Natural Gas / LP (See Accessory)
Electrical Requirements	120V
Circuit Breaker (A)	15 or 20 A
Frequency (Hz)	60 Hz

DIMENSION & WEIGHT

Product Dimension (W x D x H) (in)	30" x 26" x 35 1/2"
Required Cutout Size (W x D x H) (in)	30 1/8" x 24"-25" x 35 1/2"-36 1/2"
Product Net Weight	200 lbs.

ACCESSORIES (NOT INCLUDED)

- Liquid Propane Gas Conversion Kit
- High Altitude Conversion Kits for LP/Natural Gas

WARRANTY

2 Year Warranty On Parts and Labor

HRF3601F

36 in. 4 Door Counter Depth French Door Freestanding Refrigerator with Automatic Ice Maker

**CAPACITY**

Total Unit Gross Capacity	20.85 cu. ft.
Refrigerator Gross Capacity	15.16 cu. ft.
Freezer Gross Capacity	5.69 cu. ft.

FEATURES

Counter Depth French Door
 2-Drawer Freezer Provides Better Organization
 A Full-Width Chiller Drawer Provides Flexible Storage
 Retractable Shelf Designed To Fit Taller Items With Ease
 Dual Cycle and Dual Air-Cooled Refrigeration System
 2 Large Humidity Controlled Fresh Food Drawers
 Automatic Ice-Maker

TECHNICAL DETAILS

Rated Current (A)	2.7 A
Defrost Current (A)	3.5 A
Volts (V)	115 V
Frequency (Hz)	60 Hz
Plug Type	120V-3 Prong
Refrigerant	R134a, 6.35 oz.

REFRIGERATOR

Lighting	High-Efficiency LED
Number of Shelves - Refrigerator	5
Adjustable Shelves - Refrigerator	4 Half-Width
Shelf Material - Refrigerator	Tempered Glass
Type of Shelves - Refrigerator	Tempered Glass
Gallon Storage Bins	4
Humidity Control Drawer	2
Defrost Process Freezer	Automatic
Defrost Process Refrigerator	Frost-Free
Ice Maker	Yes
Water Filter	Yes

Warranty

2 year warranty on parts and labor

