



SPECIFICATIONS

Input Voltage.....	208-240VAC, 3-Phase
Kilowatt Rating.....	36 KW
Maximum Amperage.....	90 AMPS @ 208VAC (3-Phase)
Water Inlet.....	3/8" Compression
Steam Outlet.....	1.0" NPT
Safety Valve.....	3/4" NPT
Maximum Room Size (cubic Feet).....	1250

POWERPAK™ Series Standard Equipment:

- All system components come packaged together for convenient ordering and the elimination of errors
- Pre-installed 3/4" NPT pop-safety valve.
- Fully programmable digital control system: Convenient and easy to use
- 7 day programmability: Specific to both time and temperature and optimized for day-to-day individual settings
- PowerFlush™ inner-tank cleaning system: Automated pressurized decalcification system helps eliminate sediment build-up
- Stainless steel split-tank design adds longevity by separating the heating function from the water feed function
- Constant steam at a constant rate: no irritating steam lags or bursts
- Superior Heating Elements: A level of corrosion resistance far superior to copper, brass or stainless steel
- 1 Year parts and labor in-field warranty, 5 years at factory
- On Demand Steam with included Mechanical Timer
- 1" NPT steam line
- Can be plumbed 50 ft. from the shower without upsizing the generator.
- Stainless steel construction throughout.
- Temp Sensor with 50ft Lead wires is included

Installation Notes: Must be installed by licensed electrician. Install this generator according to the supplied installation guide. Follow local plumbing and electrical codes. Unit must be accessible. Generator is factory sized: L x W x H = Cubic Feet. Choose the appropriate generator. For every additional foot of ceiling height over 8 ft, use the next larger generator. Always round up when calculating the total cubic feet.

Product Specification Basics:

The steam generator unit dimensions shall approximately be 16-1/4" L x 18-1/4" W x 32" H in dimension. The generator is made from stainless steel and includes: PowerFlush & Split Tank. Also included is a Master Controller mounted on generator unit.

Product Information:

Length.....16-1/4in.
 Width.....18-1/4 in.
 Height.....32in.

Shipping Information:

Weight.....123 lbs.
 Length.....23 in.
 Width.....23 in.
 Height.....36 in.

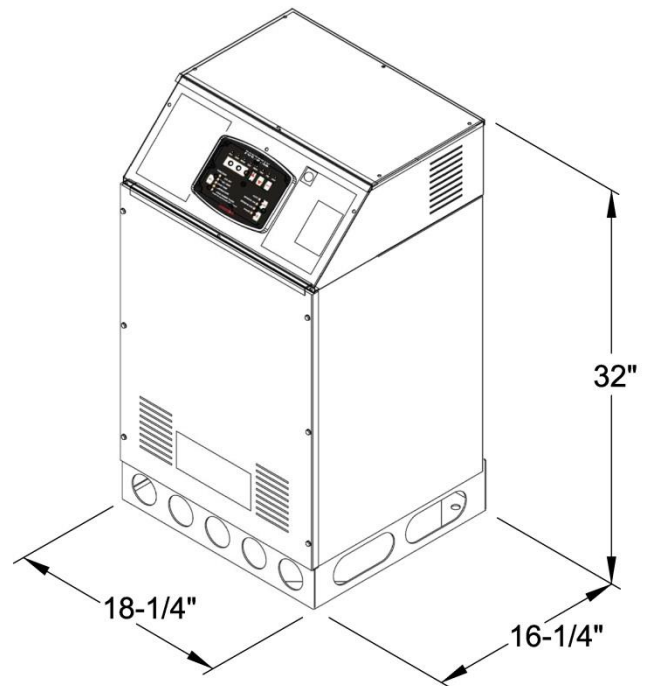

For any further assistance please contact ThermaSol at 800.776.0711 or sales@thermasol.com

Visit www.thermasol.com for a complete product definition