



T&S BRASS AND BRONZE WORKS, INC.

2 Saddleback Cove / P.O. Box 1088
Travelers Rest, SC 29690

Model No.

B-0891

Item No.

Travelers Rest, SC: 800-476-4103 • Simi Valley, CA: 800-423-0150 • Fax: 864-834-3518 • www.tsbrass.com



ADA Compliant

This Space for Architect/Engineer Approval

Job Name _____ Date _____

Model Specified _____ Quantity _____

Customer/Wholesaler _____

Contractor _____

Architect/Engineer _____

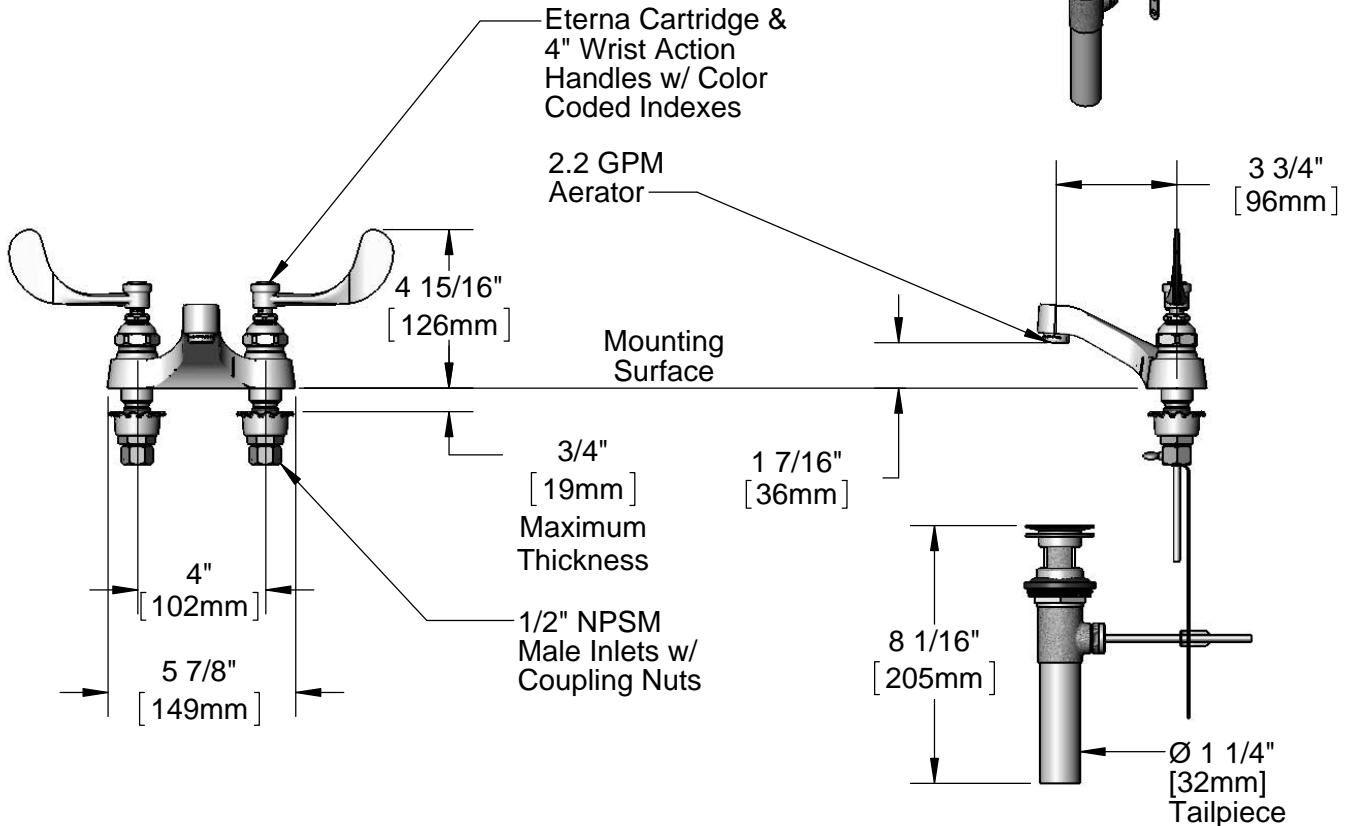
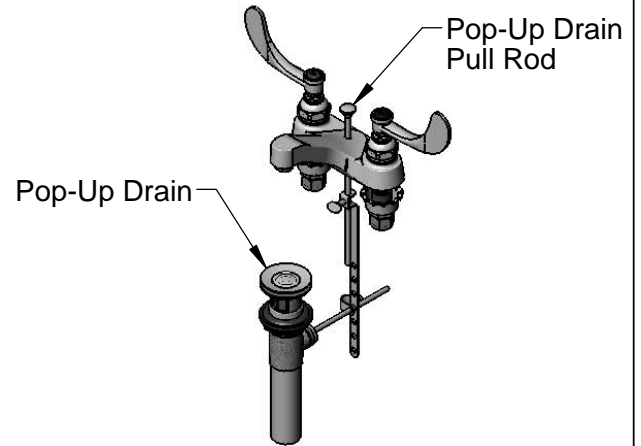
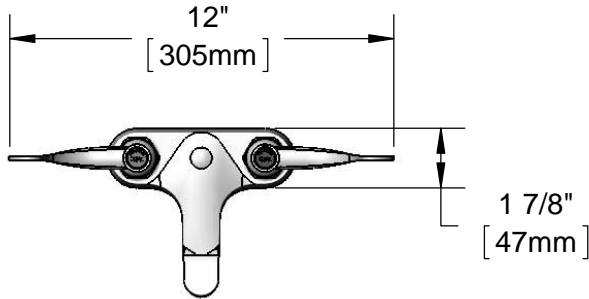

Rough-In Requirement:
(2) \varnothing 1 1/8" [29mm] Mounting Holes

Product Specifications:
4" Medical Deck Mount Mixing Faucet, Eterna Cartridges, 4" Wrist Action Handles, 2.2 GPM Aerator, 1/2" NPSM Male Inlets w/ Coupling Nuts & Pop-Up Drain

Product Compliance:
ASME A112.18.1 / CSA B125.1
NSF 61 - Section 9
NSF 372 (Low Lead Content)
ANSI A117.1 (ADA)

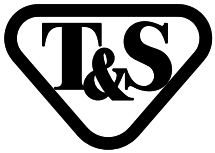

T&S BRASS AND BRONZE WORKS, INC.
 2 Saddleback Cove / P.O. Box 1088
 Travelers Rest, SC 29690

Model No.
B-0891
 Item No.

Travelers Rest, SC: 800-476-4103 • Simi Valley, CA: 800-423-0150 • Fax: 864-834-3518 • www.tsbrass.com

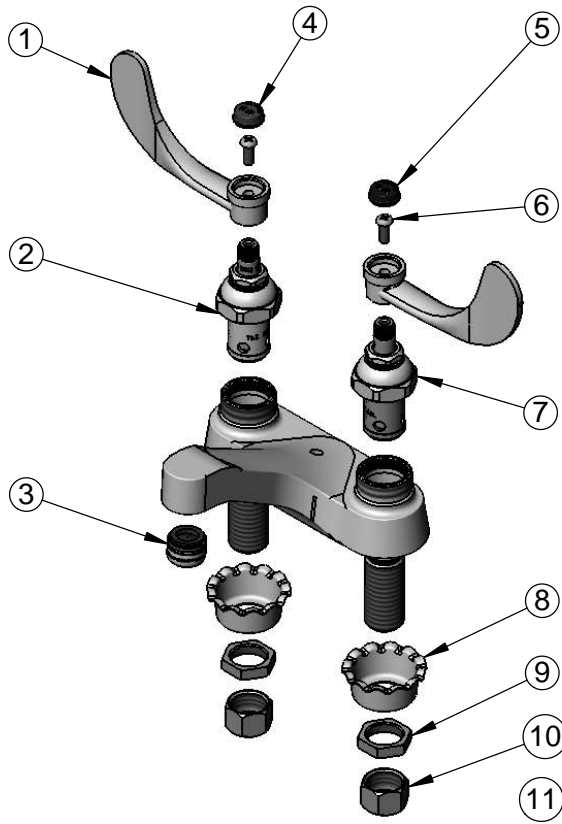

ITEM NO.	SALES NO.	DESCRIPTION
1	B-WH4	4" Wrist Action Handle
2	006010-40	Eterna Cartridge, RTC (Teflon)
3	B-0199-03	2.2 GPM Aerator, 13/16-27 UN Male
4	001194-45	Red Index - HW
5	001686-45	Blue Index - CW
6	000925-45	Lab Handle Screw
7	006009-40	Eterna Cartridge, LTC (Teflon)
8	001000-45	Rosette Washer
9	002954-45	Shank Lock Nut
10	000958-20	Coupling Nut
11	B-0898	Pop-Up Waste Drain

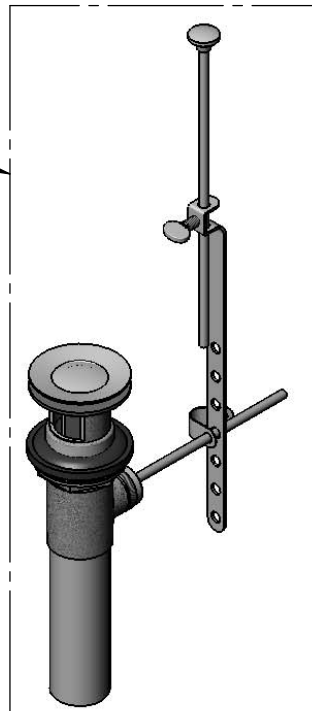

Product Specifications:

4" Medical Deck Mount Mixing Faucet, Eterna Cartridges, 4" Wrist Action Handles, 2.2 GPM Aerator, 1/2" NPSM Male Inlets w/ Coupling Nuts & Pop-Up Drain

Product Compliance:

ASME A112.18.1 / CSA B125.1
 NSF 61 - Section 9
 NSF 372 (Low Lead Content)
 ANSI A117.1 (ADA)