

CD0590-5505-HSB-RB-2.0-TRM
Shower/Hand Shower Trim
Installation Guide

Model Number	Specification
<input type="checkbox"/> CD0590-5505-HSB-RB-2.0-TRM <i>Shower/Hand Shower Trim</i>	Shower/hand shower trim includes wall elbow, 60" flexible metal hose, in-line vacuum breaker, 30" slide bar, 3 mode hand shower and 5 mode showerhead featuring 2.0 gpm (7.6 L/min) flow restrictors. Components made from metal and nonmetallic materials plated in standard polished chrome finish.
Warranty	
<p>Limited Lifetime - to the original end purchaser in consumer installations. 5 Years - for commercial installations.</p> <p>Refer to www.symmons.com/warranty for complete warranty information.</p>	

Dimensions

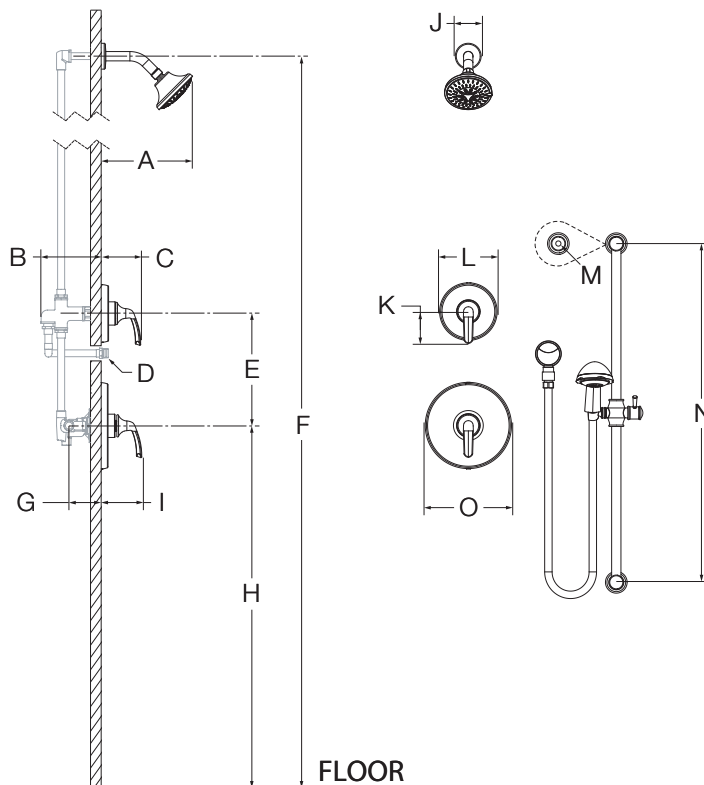

Measurements	
A	8", 203 mm
B	4 7/8", 124 mm
C	3 1/2", 89 mm
D	Male 1/2" NPT must protrude 3/8" (13 mm) from finished wall
E	Ref. 10", 254 mm
F	Ref. 77", 1956 mm
G	Rough-in 2 3/8" ± 1/2", 60 mm ± 13 mm
H	Ref. 32", 813 mm
I	3 1/2", 89 mm
J	Ø 2 1/4", 57 mm
K	2 3/4", 70 mm
L	Ø 5", 127 mm
M	Hole Size (2x) Ø 1/4", 6 mm
N	29 1/2", 749 mm
O	Ø 7 1/2", 191 mm

Notes:

- 1) All dimensions measured from nominal rough-in (see G as reference).
- 2) Dimensions subject to change without notice.