

Location:

  
**SYMMONS<sup>®</sup> Lig-Res<sup>™</sup>**  
**Diverter Valve Trim 57-2DIV-TRM**  
**Ligature Resistant**  
**Specification Submittal**



**Feature Highlights**

- Dual Outlet Diverter Valve Trim with ligature resistant knob
- Trim is used with Symmons dual-port diverter valve
- Vandal resistant screws
- Metal construction
- Polished chrome finish (standard)

**Model Numbers**

- 57-2DIV-TRM Dual outlet diverter valve trim (diverter valve not included)

**Finish Options / Modifications**

*Append appropriate -suffix to model number*

- Polished Chrome (standard finish)

**Disclaimers**

- Product is designed to reduce likelihood that unit could be used as a device for hanging.
- Product is not a substitute for the evaluation, treatment or appropriate supervision of persons at risk of suicide

**Warranty**

- Limited Lifetime - to the original end purchaser in consumer installations.
- 5 years - for commercial installations

**Standards / Certifications**

ASME A112.18.1/CSA B125.1

**Dimensions** Lig-Res Diverter Valve Trim, 57-2DIV-TRM

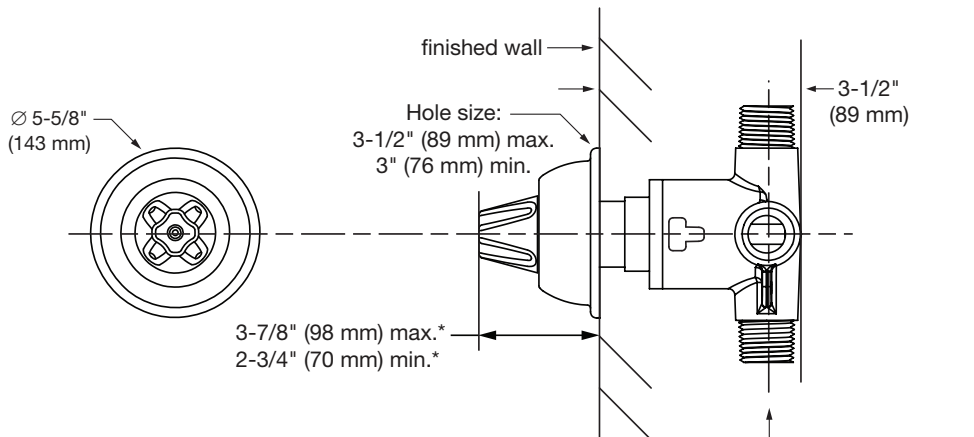

**Notes:**

- (1) Dimensions identified with an asterisk (\*) apply when diverter valve is installed without primary mixing control valve. When diverter valve is coupled with a primary mixing control valve, then dimension is determined by rough-in drawing provided with mixing control valve.

- (2) Dimensions subject to change without notice