

Location:

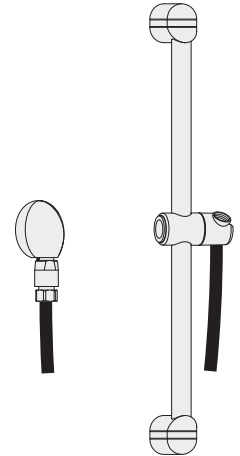

Hand Shower Accessory, 442HSB-LHS

Specification Submittal



Model Numbers

- 442HSB-LHS Hose, slide bar, wall connection and flange for hand shower

Finish Options

Append appropriate -suffix to model number.

- STN Satin nickel finish
- Polished chrome finish (standard)

Feature Highlights

- 5 foot flexible metal hose with in-line vacuum breaker, wall connection, cradle and flange
- 30 inch slide bar for mounting hand shower
- Polished chrome finish (standard)

Warranty

- Limited Lifetime - to the original end purchaser in residential / consumer installations.
- 5 years - for commercial installations

Standards / Certifications

ASME A112.18.1-2005/CSA B125.1-05

Dimensions Hand Shower Accessory, 442HSB-LHS

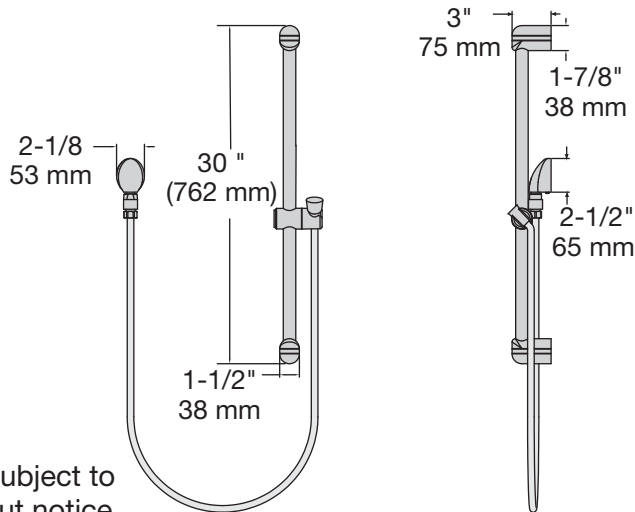

Note: Dimensions subject to change without notice.

Symmons Industries, Inc. ■ 31 Brooks Drive ■ Braintree, MA 02184
 (800) 796-6667, (781) 848-2250 ■ Fax (800) 961-9621, (781) 664-1300
 Website: www.symmons.com ■ Email: customerservice@symmons.com

