









6600, 6601, 6602

## Operation & Maintenance Manual

Model Numbers	Specification
<ul style="list-style-type: none"> <li><input type="checkbox"/> <b>6600</b> <i>Unity Shower Valve</i></li> <li><input type="checkbox"/> <b>6601</b> <i>Unity Shower System</i></li> <li><input type="checkbox"/> <b>6602</b> <i>Unity Tub/Shower System</i></li> </ul>	<p><b>6600/6601</b> Shower system powered by the Temptrol<sup>®</sup> Pressure Balancing valve. Features adjustable stop screw to limit handle turn, 1 mode showerhead with easy to clean rubber nozzles and standard 2.5 gpm (9.5 L/min) flow restrictor. Components made from metal and nonmetallic materials plated in standard polished chrome finish.</p>
<p><b>Modifications</b></p> <ul style="list-style-type: none"> <li><input type="checkbox"/> <b>-1.5</b>  1.5 gpm (5.7 L/min) flow restrictor</li> <li><input type="checkbox"/> <b>-2.0</b>  2.0 gpm (7.6 L/min) flow restrictor</li> <li><input type="checkbox"/> <b>-143</b> Euro-Flo three mode showerhead in place of Clear-Flo</li> <li><input type="checkbox"/> <b>-145</b> Euro-Flo five mode showerhead in place of Clear-Flo</li> <li><input type="checkbox"/> <b>-231</b> Super showerhead in place of Clear-Flo</li> <li><input type="checkbox"/> <b>-SS</b> Slip spout on any tub/shower unit</li> <li><input type="checkbox"/> <b>-X</b> Integral service stops</li> <li><input type="checkbox"/> <b>-CHKS</b> Integral check stops</li> <li><input type="checkbox"/> <b>-IPS</b> 1/2" female IPS connections</li> <li><input type="checkbox"/> <b>-REV</b> Reverse coring for back to back installations</li> <li><input type="checkbox"/> <b>-LP</b> Loop handle</li> <li><input type="checkbox"/> <b>-OP</b> 13" oval plate</li> <li><input type="checkbox"/> <b>-L/HD</b> Less showerhead</li> <li><input type="checkbox"/> <b>-TRM</b> Trim only, valve not included</li> <li><input type="checkbox"/> <b>-STN</b> Satin Nickel finish</li> </ul>	<p><b>6602</b> Tub/shower system powered by the Temptrol<sup>®</sup> Pressure Balancing valve. Features adjustable stop screw to limit handle turn, diverter tub spout, 1 mode showerhead with easy to clean rubber nozzles and standard 2.5 gpm (9.5 L/min) flow restrictor. Components made from metal and nonmetallic materials plated in standard polished chrome finish.</p> <div style="text-align: right;">   </div>
	<p><b>Compliance</b></p> <p>-ASME A112.18.1/CSA B125.1 -WaterSense 1.5 gpm (5.7 L/min) 2.0 gpm (7.6 L/min)</p> <div style="text-align: right;">   </div> <p><u>For California Residents</u> <b>WARNING:</b> This product contains chemicals known to the State of California to cause cancer, birth defects, or other reproductive harm.</p>
<p><b>Note:</b> Append appropriate -suffix to model number.</p>	<p><b>Warranty</b></p> <p><b>Limited Lifetime</b> - to the original end purchaser in consumer/residential installations. <b>5 Years</b> - for industrial/commercial installations. Refer to <a href="http://www.symmons.com/warranty">www.symmons.com/warranty</a> for complete warranty information.</p>

## Dimensions

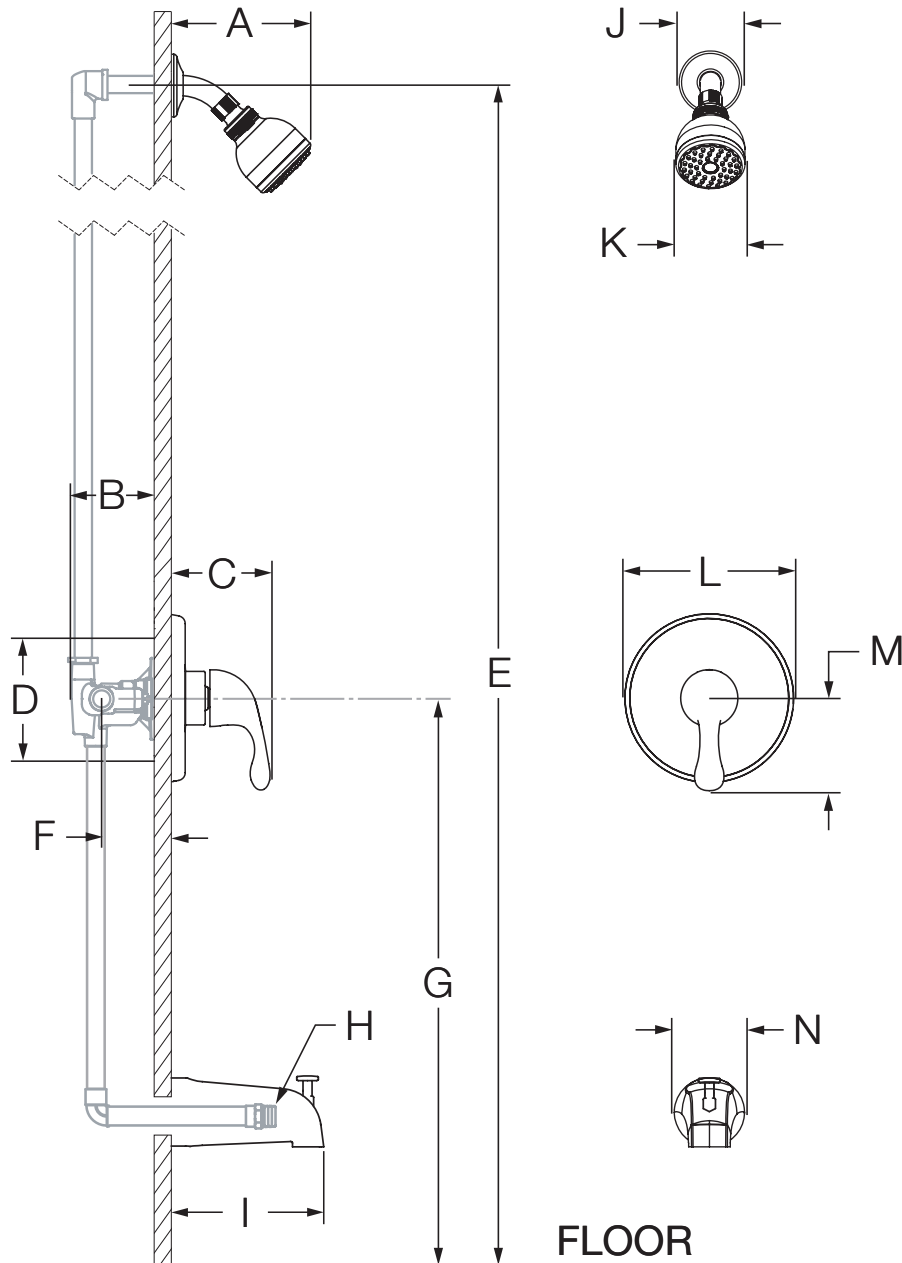

Measurements	
A	6 3/8", 162 mm
B	3 1/2", 89 mm
C	3 3/4", 95 mm
D	Shower Valve Hole Size Min. Ø 3", 76 mm Max. Ø 4" 102 mm
E	Ref. 77", 1956
F	Rough-in 2 3/8" ± 1/2", 60 mm ± 13 mm
G	Ref. 32", 813 mm (6602) Ref. 42", 1067 mm (6601, 6600)
H	Male 1/2" NPT fitting must protrude 4" from finished wall
I	5 1/4", 133 mm
J	Ø 2 1/2", 64 mm
K	Ø 2 3/4", 70 mm
L	Ø 6 3/8", 162 mm
M	3 1/2", 89 mm
N	Ø 2 1/2", 64 mm

### Notes:



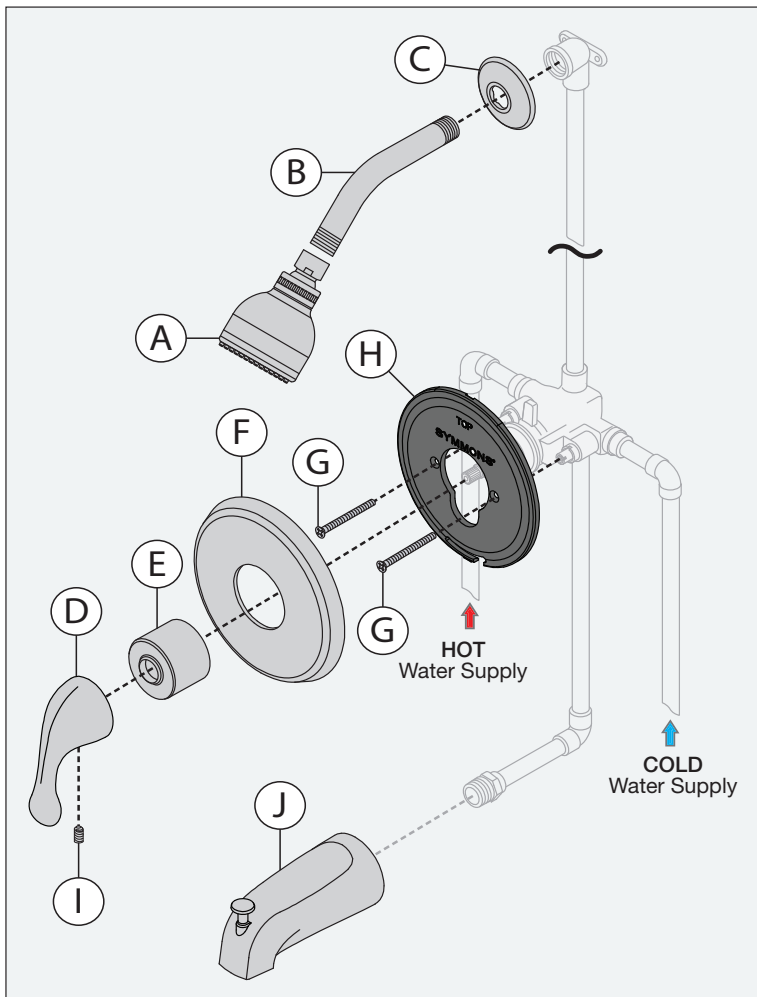

- 1) All dimensions measured from nominal rough-in (see F as reference).
- 2) Dimensions subject to change without notice.

## Parts Breakdown

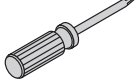

Replacement Parts		
Item	Description	Part Number
A	Showerhead	4-141*
B C	Shower Arm & Flange	300S*
D I	Handle Assembly	RTS-064*
E	Dome Cover	T-19*
F G H	Shower Escutcheon Kit	6600-ESC*
J	Tub Spout	054*

**\*Note:** Append -STN to part number for Satin Nickel finish.

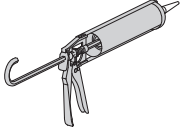
Tools Required	
Adjustable wrench	
Allen wrench (1/8")	
Phillips head screwdriver	
Plumber tape	
Silicone	

### Notes:

- 1) Apply a bead of silicone around the perimeter of all shower trim installed flush to the finished wall. Leave opening on bottom of escutcheon for weep hole.
- 2) Apply plumber tape to all threaded connections.

## Installation

**Note:**

For valve body installation, please see valve body manual.

- 1) Install mounting plate (H) to shower valve. Secure with two screws (G).

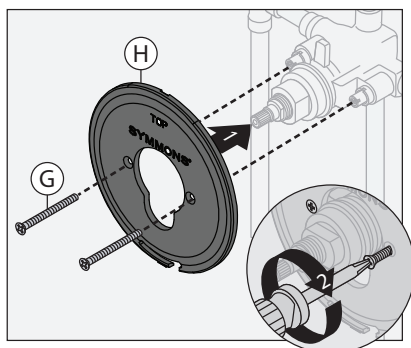

- 2) Attach shower escutcheon (F) to mounting plate (H).

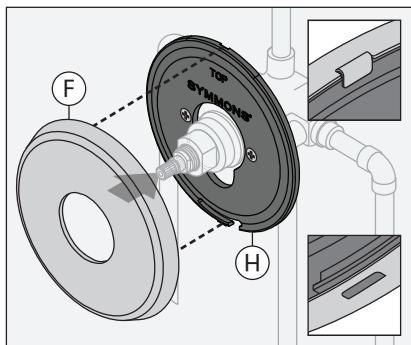

**Note:** Tabs should snap into place.

- 3) Install dome cover (E) to valve by turning clockwise.

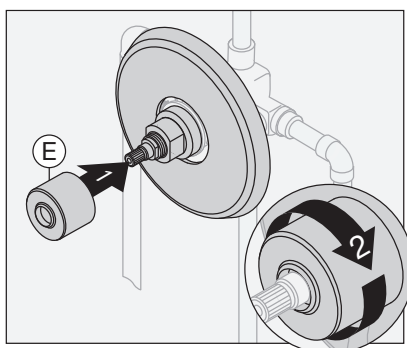

- 4) Install handle (D) to valve and secure with set screw (I).

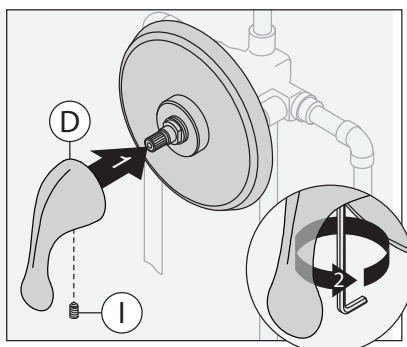

**Note:** Handle should be facing the 6 o'clock position.

- 5) Install tub spout (J) to pipe fitting. Turn clockwise to secure.

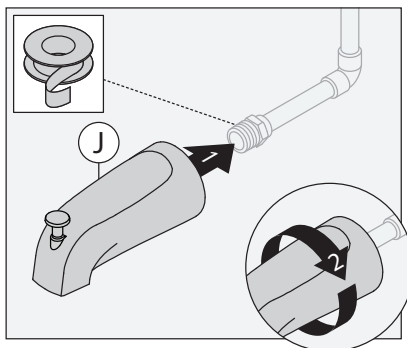

- 6) Attach shower arm (B) and flange (C) to vertical shower pipe. Turn clockwise to tighten.

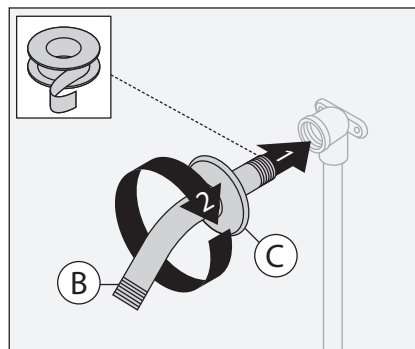

- 7) Install showerhead (A) to shower arm (B). Turn clockwise to tighten.

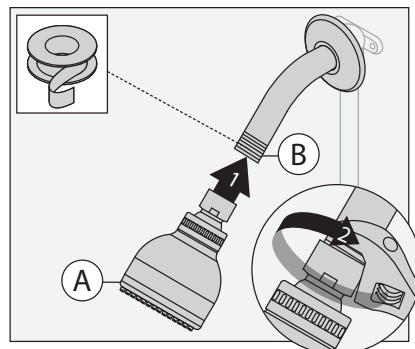

## Operation (Temperature Control)

1) Turn shower handle counterclockwise approximately 1/4 turn to put valve in cold position.

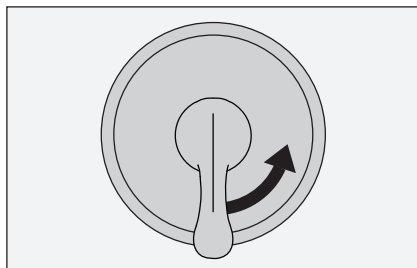

2) Turn shower handle counterclockwise approximately 1/2 turn to put valve in warm position.

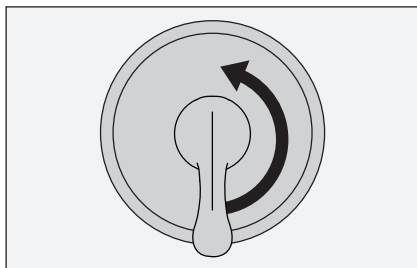

3) Turn shower handle counterclockwise approximately 3/4 turn to put valve in hot position.

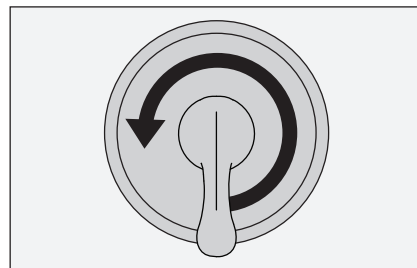

## Operation (Diverter Control)

1) Diverter lever in down position for tub spout operation.

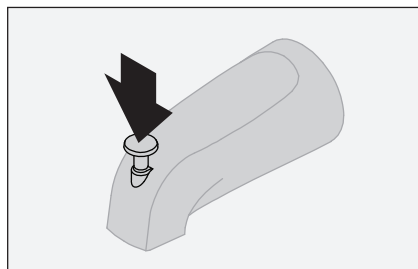

2) Diverter lever in up position for shower operation.

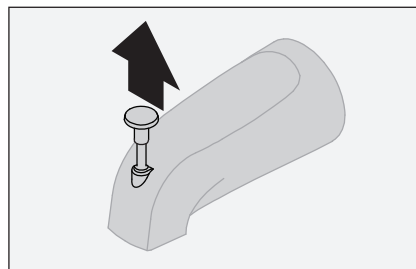







## Troubleshooting Chart

Problem	Cause	Solution
Finish is spotting.	Elements in water supply may cause water staining on finish.	Clean finished trim area with a soft cloth using mild soap and water or a non-abrasive cleaner and then quickly rinse with water.



6600, 6601, 6602

## Manual de funcionamiento y mantenimiento

Números de modelo	Especificación
<ul style="list-style-type: none"> <li><input type="checkbox"/> <b>6600</b> <i>Válvula para ducha Unity</i></li> <li><input type="checkbox"/> <b>6601</b> <i>Sistema de ducha Unity</i></li> <li><input type="checkbox"/> <b>6602</b> <i>Sistema para bañera y ducha Unity</i></li> </ul>	<p><b>6600/6601</b> Sistema para ducha con válvula compensadora de presión Temptrol<sup>®</sup>. Incluye un tornillo con tope ajustable para limitar el giro de la manija, con un cabezal de ducha de 1 función con boquillas de goma fáciles de limpiar y un reductor de caudal de 2.5 gpm (9.5 L/min). Los componentes están hechos de materiales metálicos y no metálicos recubiertos con un acabado en cromo pulido estándar.</p>
<p><b>Modificaciones</b></p> <ul style="list-style-type: none"> <li><input type="checkbox"/> <b>-1.5</b>  Reductor de caudal de 1.5 gpm (5.7 L/min)</li> <li><input type="checkbox"/> <b>-2.0</b>  Reductor de caudal de 2.0 gpm (7.6 L/min)</li> <li><input type="checkbox"/> <b>-143</b> Cabezal de ducha de tres funciones Euro-Flo en lugar de Clear-Flo</li> <li><input type="checkbox"/> <b>-145</b> Cabezal de ducha de cinco funciones Euro-Flo en lugar de Clear-Flo</li> <li><input type="checkbox"/> <b>-231</b> Cabezal de ducha Super en lugar de Clear-Flo</li> <li><input type="checkbox"/> <b>-SS</b> Surtidor de montaje deslizante en cualquiera de las unidades para bañera y ducha</li> <li><input type="checkbox"/> <b>-X</b> Llaves de paso integradas</li> <li><input type="checkbox"/> <b>-CHKS</b> Válvulas de retención integradas</li> <li><input type="checkbox"/> <b>-IPS</b> Salida de unión hembra de 1/2" I.P.S.</li> <li><input type="checkbox"/> <b>-REV</b> Conexión inversa para instalaciones encontradas</li> <li><input type="checkbox"/> <b>-LP</b> Manija en bucle</li> <li><input type="checkbox"/> <b>-OP</b> Placa ovalada de 13"</li> <li><input type="checkbox"/> <b>-L/HD</b> Sin el cabezal de ducha</li> <li><input type="checkbox"/> <b>-TRM</b> Borde solamente, válvula no incluida</li> <li><input type="checkbox"/> <b>-STN</b> Acabado de níquel satinado</li> </ul>	<p><b>6602</b> Sistema para bañera y ducha con válvula compensadora de presión Temptrol<sup>®</sup>. Incluye un tornillo con tope ajustable para limitar el giro de la manija, un tubo surtidor de agua con desviador para la bañera, un cabezal de ducha de 1 función con boquillas de goma fáciles de limpiar y un reductor de caudal de 2.5 gpm (9.5 L/min). Los componentes están hechos de materiales metálicos y no metálicos recubiertos con un acabado en cromo pulido estándar.</p> <div style="text-align: right;">   </div>
	<p><b>Cumplimiento</b></p> <ul style="list-style-type: none"> <li>-ASME A112.18.1/CSA B125.1</li> <li>-WaterSense 1.5 gpm (5.7 l/min) 2.0 gpm (7.6 L/min)</li> </ul> <div style="text-align: right;">   </div>
	<p><b>Garantía</b></p> <p><b>Limitada de por vida:</b> para el comprador original del producto en instalaciones del consumidor/residenciales. <b>5 años</b> - para instalaciones industriales y comerciales. Diríjase a <a href="http://www.symmons.com/warranty">www.symmons.com/warranty</a> para obtener información completa sobre la garantía.</p>

**Nota:** Anexar el -sufijo apropiado al número de modelo.

## Dimensiones

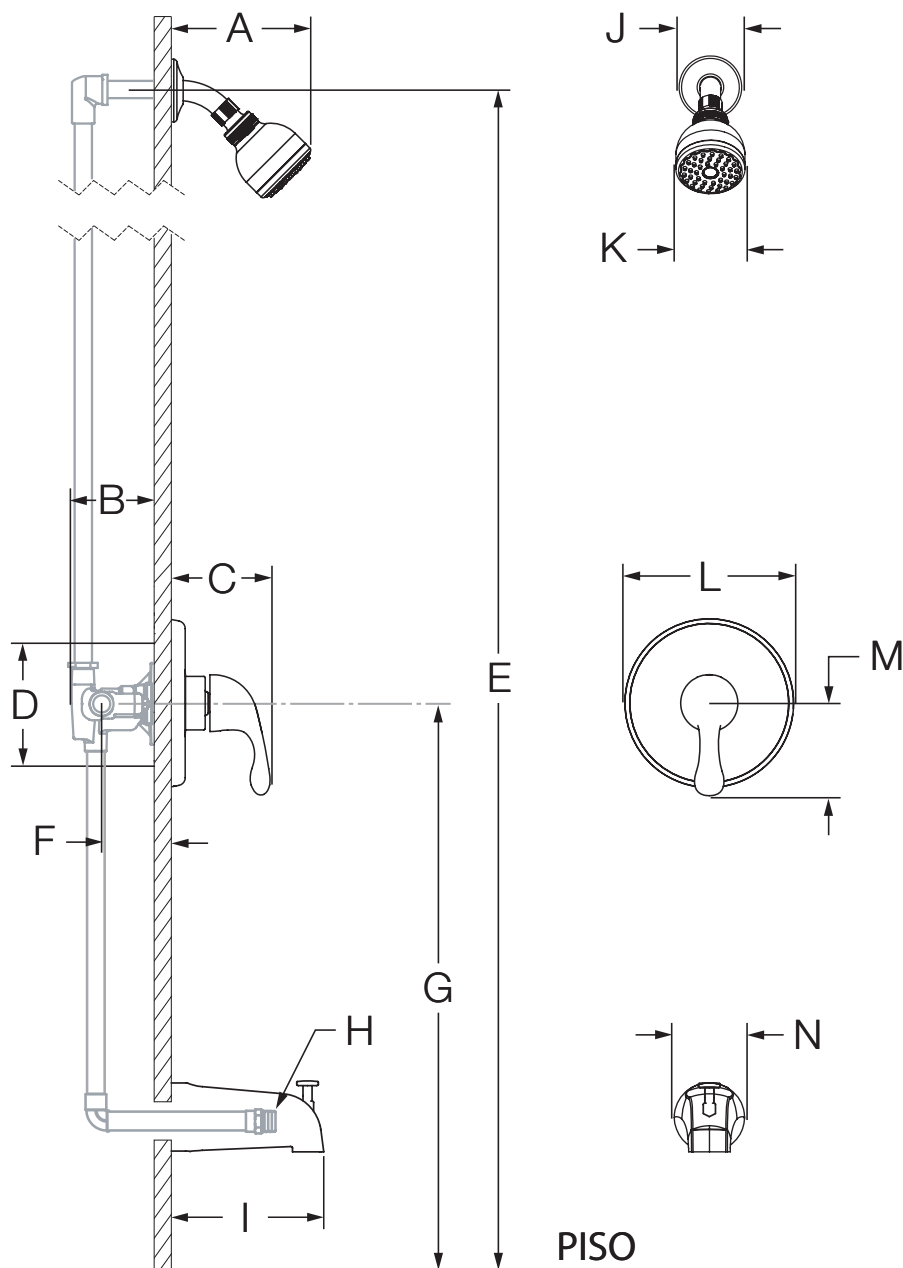

Medidas	
A	6 3/8", 162 mm
B	3 1/2", 89 mm
C	3 3/4", 95 mm
D	Tamaño de los orificios de la válvula para ducha Mín. Ø 3", 76 mm Máx. Ø 4", 102 mm
E	Ref. 77", 1956
F	Empotrado 2 3/8" ± 1/2", 60 mm ± 13 mm
G	Ref. 32", 813 mm (6602) Ref. 42", 1067 mm (6601, 6600)
H	La rosca macho NPT de 1/2" debe sobresalir 4" de la pared terminada
I	5 1/4", 133 mm
J	Ø 2 1/2", 64 mm
K	Ø 2 3/4", 70 mm
L	Ø 6 3/8", 162 mm
M	3 1/2", 89 mm
N	Ø 2 1/2", 64 mm

### Notas:

- 1) Todas las dimensiones tomadas desde el empotrado (ver F para referencia).
- 2) Las dimensiones están sujetas a cambios sin previo aviso.

## Desglose de piezas

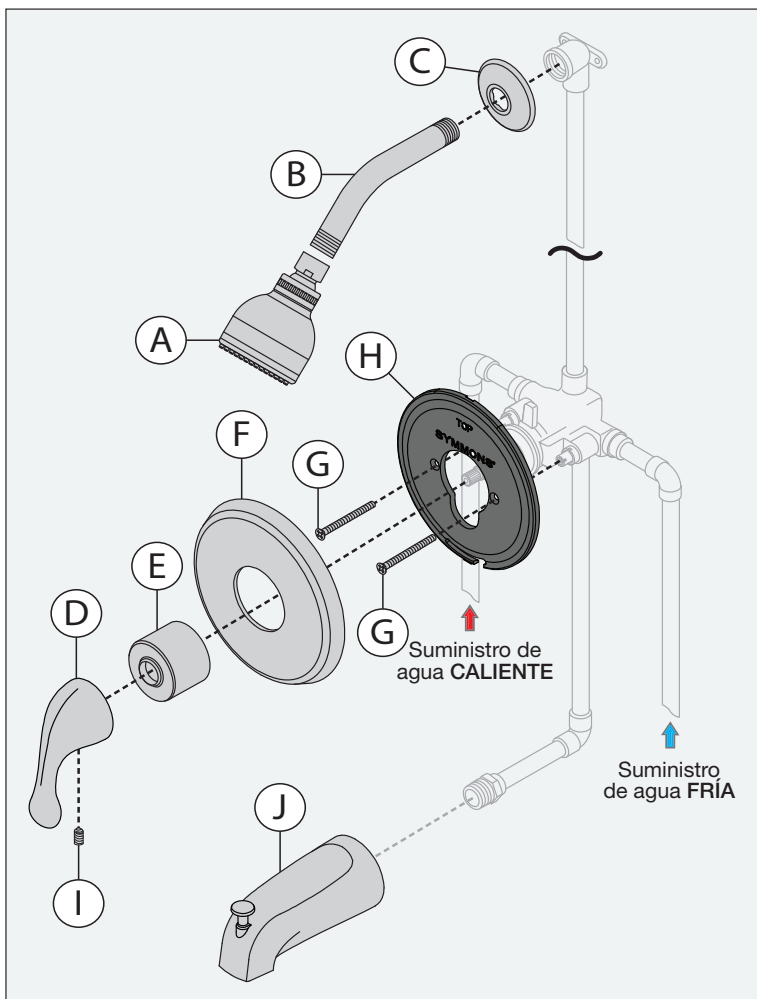

Repuestos		
Artículo	Descripción	Número de pieza
A	Cabezal de ducha	4-141*
B C	Brazo de la ducha y brida	300S*
D I	Ensamblaje de la manija	RTS-064*
E	Cubierta del domo	T-19*
F G H	Juego de montaje decorativo para la ducha	6600-ESC*
J	Surtidor para bañera	054*

\*Nota: Anexar -STN al número de pieza para el acabado de níquel satinado.

Herramientas requeridas	
Llave inglesa	
Llave Allen (1/8")	
Destornillador phillips	
Cinta de teflón	
Silicona	

### Notas:

- 1) Aplique una gota de silicona alrededor del perímetro del borde de la ducha a nivel de la pared terminada. Deje un orificio en la parte inferior de la placa para drenar la humedad.
- 2) Coloque cinta de teflón en todas las uniones roscadas.



## Instalación

### Nota:

Para instalar el cuerpo de la válvula, vea el manual de la válvula.

- 1) Instale la placa de montaje (H) a la válvula de la ducha. Sujételo con dos tornillos (G).

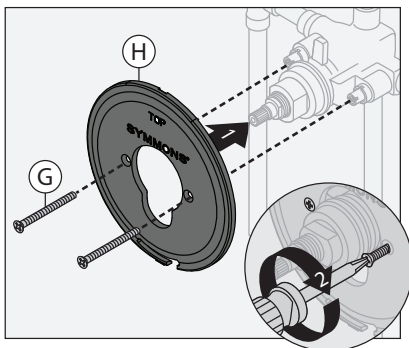

- 2) Una el montaje decorativo de la ducha (F) a la placa de montaje (H).

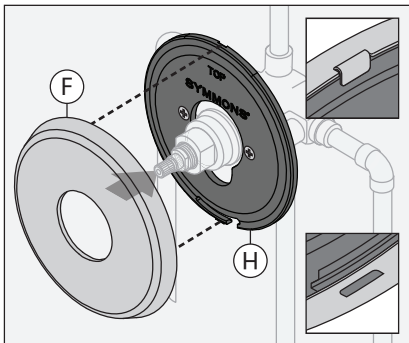

**Nota:** Las lengüetas deben encajar en sus sitios.

- 3) Para instalar la cubierta del domo (E) a la válvula gire en sentido de las agujas del reloj.

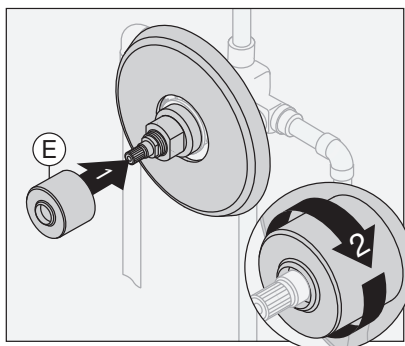

- 4) Instale el mango (D) a la válvula y ajústelo con un tornillo de presión (I).

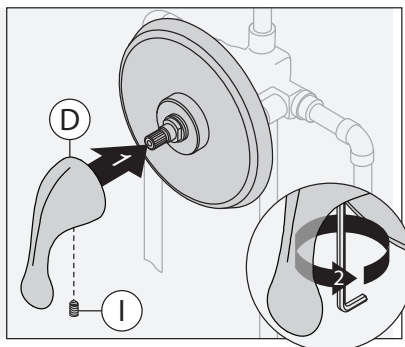

### Nota:

La manija debe situarse en la posición de las 6 en punto.

- 5) Instale el surtidor para la bañera (J) a la conexión de la tubería. Girar en el sentido de las agujas del reloj para ajustar.

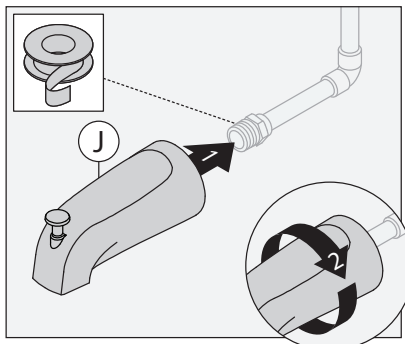

- 6) Una el brazo de la ducha (B) y la brida (C) al tubo vertical de la ducha. Gire en el sentido de las agujas del reloj para apretar.

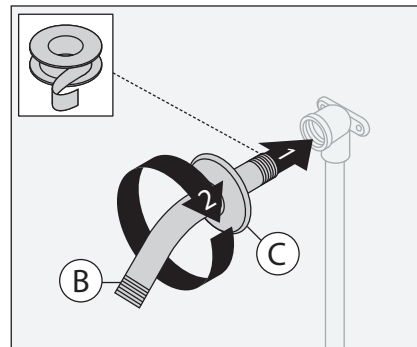

- 7) Instale el cabezal de ducha (A) al brazo de la ducha (B). Gire en el sentido de las agujas del reloj para apretar.

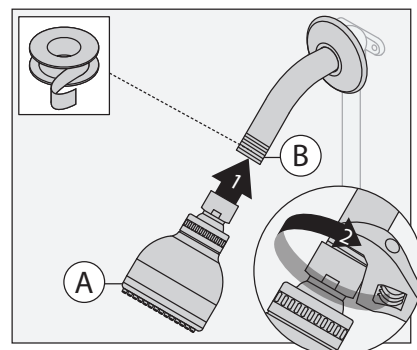

## Funcionamiento (Regulador de temperatura)

1) Gire el mango de la ducha 1/4 de vuelta en sentido contrario a las agujas del reloj para colocar la válvula en la posición de agua fría.

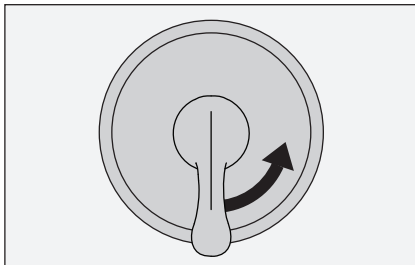

2) Gire el mango de la ducha 1/2 vuelta en sentido contrario a las agujas del reloj para colocar la válvula en la posición de agua tibia.

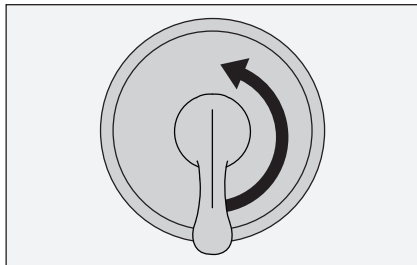

3) Gire el mango de la ducha 3/4 de vuelta en sentido contrario a las agujas del reloj para colocar la válvula en la posición de agua caliente.

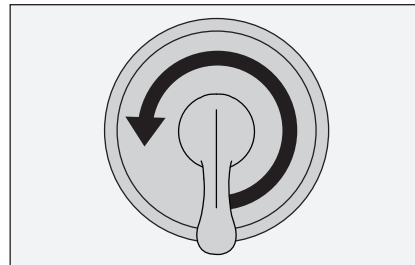

## Funcionamiento (Regulador del desviador)

1) Palanca del desviador hacia abajo para utilizar el surtidor para bañera.

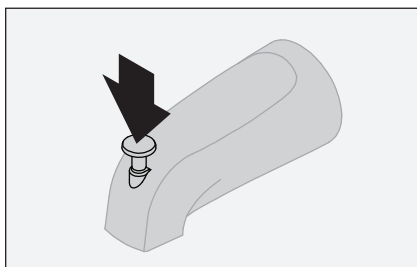

2) Palanca del desviador hacia arriba para utilizar la ducha.

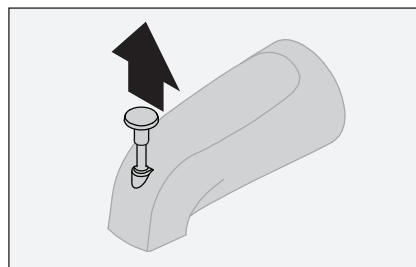







## Tabla de resolución de problemas

Problema	Causa	Solución
El acabado se está manchando.	Las partículas en el suministro de agua pueden provocar que el agua manche el acabado.	Limpie el área con acabado con un paño suave, usando jabón suave y agua o un limpiador no abrasivo, y luego enjuague rápidamente con agua.



6600, 6601, 6602

## Manuel d'utilisation et d'entretien

Numéros de modèle	Spécification
<ul style="list-style-type: none"> <li><input type="checkbox"/> <b>6600</b> <i>Vanne de douche Unity</i></li> <li><input type="checkbox"/> <b>6601</b> <i>Système de douche Unity</i></li> <li><input type="checkbox"/> <b>6602</b> <i>Système de baignoire/douche Unity</i></li> </ul>	<p><b>6600/6601</b> Système de douche alimenté par la vanne à pression autorégularisée Temptrol<sup>®</sup>. Comprend la vis d'arrêt réglable pour limiter le tournage de la poignée, une pomme de douche à 1 mode avec des embouts en caoutchouc faciles à nettoyer et un réducteur de débit de 2,5 gpm (9,5 L/min) standard. Les composants sont faits de matériaux métalliques et non métalliques au fini chrome poli standard.</p>
<p><b>Modifications</b></p> <ul style="list-style-type: none"> <li><input type="checkbox"/> <b>-1.5</b>  Réducteur de débit de 1,5 gpm (5,7 L/min)</li> <li><input type="checkbox"/> <b>-2.0</b>  Réducteur de débit de 2,0 gpm (7,6 L/min)</li> <li><input type="checkbox"/> <b>-143</b> <i>Pomme de douche Euro-Flo à trois modes au lieu du Clear-Flo</i></li> <li><input type="checkbox"/> <b>-145</b> <i>Pomme de douche Euro-Flo à cinq modes au lieu du Clear-Flo</i></li> <li><input type="checkbox"/> <b>-231</b> <i>Super pomme de douche au lieu du Clear-Flo</i></li> <li><input type="checkbox"/> <b>-SS</b> <i>Bec de baignoire à enfiler sur toute unité de baignoire-douche</i></li> <li><input type="checkbox"/> <b>-X</b> <i>Robinet d'interruption du service</i></li> <li><input type="checkbox"/> <b>-CHKS</b> <i>Valve d'arrêt intégrée</i></li> <li><input type="checkbox"/> <b>-IPS</b> <i>Raccords IPS femelles de 1/2 po</i></li> <li><input type="checkbox"/> <b>-REV</b> <i>Corps central inversé pour installations dos à dos</i></li> <li><input type="checkbox"/> <b>-LP</b> <i>Poignée en boucle</i></li> <li><input type="checkbox"/> <b>-OP</b> <i>Plaque ovale de 13 po</i></li> <li><input type="checkbox"/> <b>-L/HD</b> <i>Sans pomme de douche</i></li> <li><input type="checkbox"/> <b>-TRM</b> <i>Garniture seulement, vanne non incluse</i></li> <li><input type="checkbox"/> <b>-STN</b> <i>Fini nickel satiné</i></li> </ul>	<p><b>6602</b> Système de baignoire/douche alimenté par la vanne à pression autorégularisée Temptrol<sup>®</sup>. Comprend la vis d'arrêt réglable pour limiter le tournage de la poignée, le bec de baignoire déviateur, une pomme de douche à 1 mode avec des embouts en caoutchouc faciles à nettoyer et un réducteur de débit de 2,5 gpm (9,5 L/min) standard. Les composants sont faits de matériaux métalliques et non métalliques au fini chrome poli standard.</p> <div style="text-align: right;">   </div>
	<p><b>Conformité</b></p> <p>-ASME A112.18.1/CSA B125.1 -WaterSense 1,5 gpm (5,7 L/min) 2,0 gpm (7,6 L/min)</p> <div style="text-align: right;">   </div>
<p><b>Remarque :</b> Juxtaposer le -suffixe approprié au numéro de modèle.</p>	<p><b>Garantie</b></p> <p><b>À vie limitée</b> - à l'acheteur final original dans les installations chez le client/résidentiel. <b>5 ans</b> – pour des installations commerciales et industrielles. Se reporter au site <a href="http://www.symmons.com/warranty">www.symmons.com/warranty</a> (en anglais) pour l'information complète concernant la garantie.</p>

## Dimensions

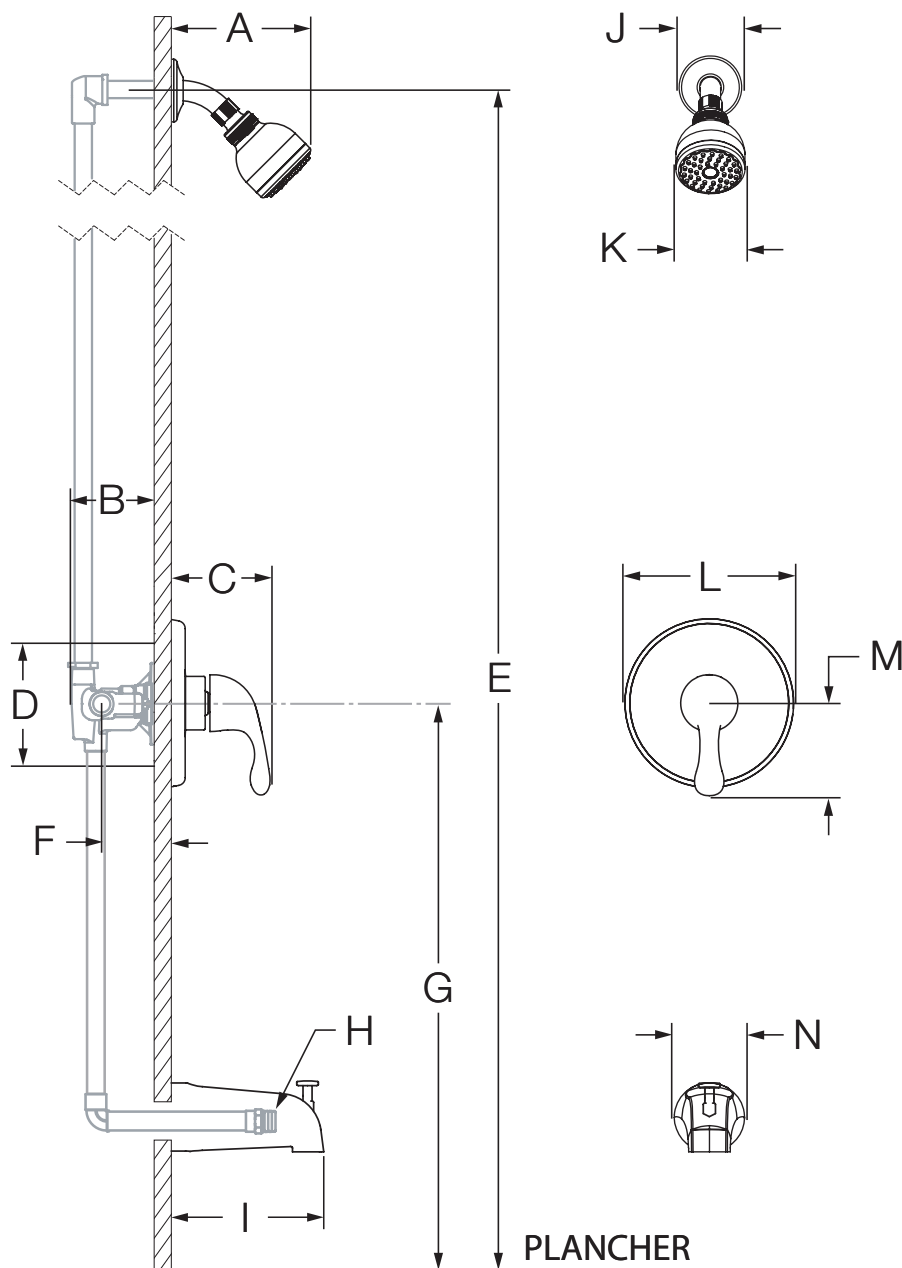

Mesures	
A	6 3/8 po, 162 mm
B	3 1/2 po, 89 mm
C	3 3/4 po, 95 mm
D	Taille du trou de la vanne de douche Min. Ø 3 po, 76 mm Max. Ø 4 po, 102 mm
E	Réf. 77 po, 1956 mm
F	Robinetterie brute 2 3/8 po ± 1/2 po, 60 mm ± 13 mm
G	Réf. 32 po, 813 mm (6602) Réf. 42 po, 1067 mm (6601, 6600)
H	Raccord NPT 1/2 po mâle doit faire saillie de 4 po du mur fini
I	5 1/4 po, 133 mm
J	Ø 2 1/2 po, 64 mm
K	Ø 2 3/4 po, 70 mm
L	Ø 6 3/8 po, 162 mm
M	3 1/2 po, 89 mm
N	Ø 2 1/2 po, 64 mm

### Remarques :

- 1) Toutes les dimensions sont mesurées à partir de la robinetterie brute nominale (voir F en référence).
- 2) Les dimensions sont sujettes à changer sans préavis.

## Liste des pièces

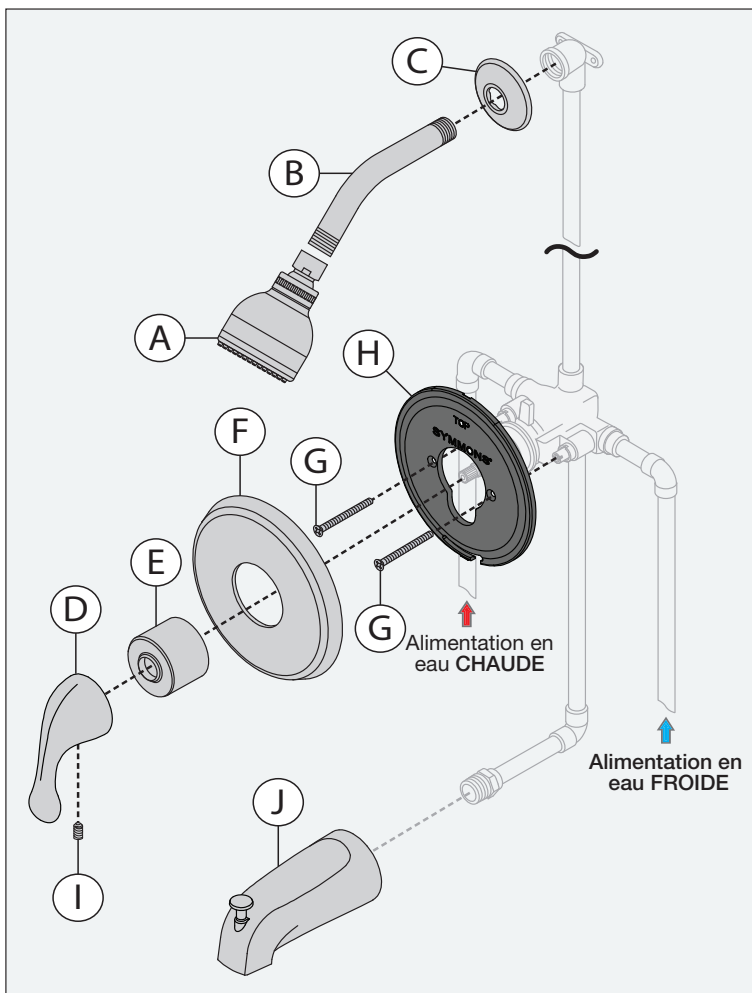

### Remarques :

- 1) Appliquez un joint de silicone autour du périmètre de la garniture de la douche installée à égalité avec le mur fini. Laissez une ouverture au fond de la rosace pour un trou d'évacuation.
- 2) Appliquez du ruban de plombier à toutes les connections filetées.

### Pièces de remplacement

Ar-ticle	Description	Numéro de pièce
A	Pomme de douche	4-141*
B C	Bras et bride de douche	300S*
D I	Assemblage De la poignée	RTS-064*
E	Couvercle en dôme	T-19*
F G H	Douche Ensemble de la rosace	6600-ESC*
J	Bec de baignoire	054*

\*Remarque : Juxtaposer le -STN au numéro de pièce pour le fini Nickel satiné.

### Outils requis

Clef ajustable	
Clef Allen (1/8 po)	
Tournevis cruciforme	
Ruban de plombier	
Silicone	

## Installation

### Remarque :

Pour l'installation du corps de vanne, veuillez consulter le manuel de corps de vanne.

- 1) Installez la plaque de montage (H) à la vanne de douche. Fixez avec deux vis (G).

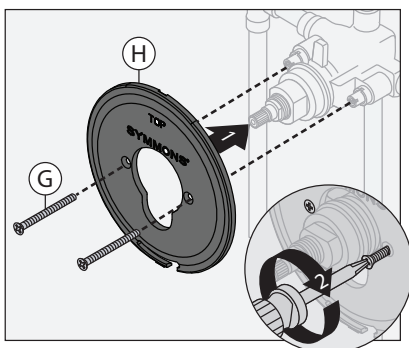

- 2) Attachez la rosace de douche (F) à la plaque de montage (H).

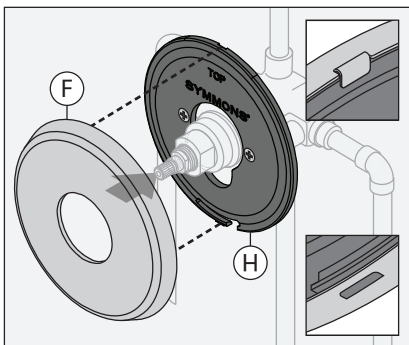

**Remarque :** Les languettes devraient s'enclencher dans la bonne position.

- 3) Installez le couvercle du dôme (E) à la vanne en tournant dans le sens des aiguilles d'une montre.

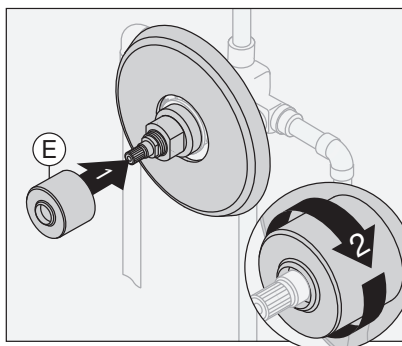

- 4) Installez la poignée (D) à la vanne et fixez avec la vis de pression (I).

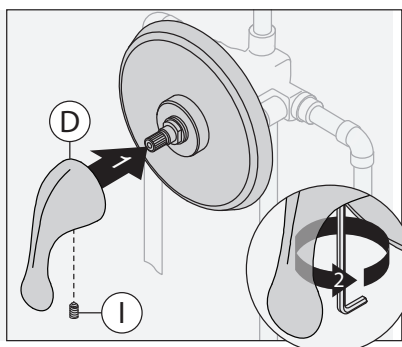

### Remarque :

La poignée devrait faire face à la position 18h sur l'horloge.

- 5) Installez le bec de baignoire (J) au raccord de tuyauterie. Tournez dans les sens des aiguilles d'une montre pour fixer en place.

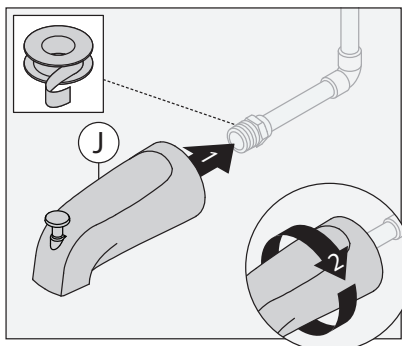

- 6) Attachez le bras de douche (B) et la bride (C) au tuyau de douche vertical. Tournez dans les sens des aiguilles d'une montre pour serrer.

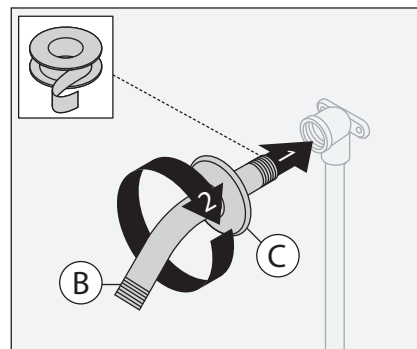

- 7) Installez la pomme de douche (A) au bras de douche (B). Tournez dans les sens des aiguilles d'une montre pour serrer.

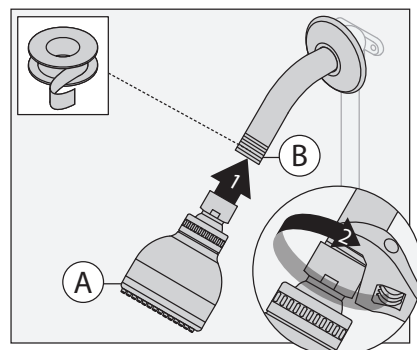

## Fonctionnement (Contrôle de la température)

1) Tournez la poignée de douche dans le sens contraire des aiguilles d'une montre approximativement 1/4 de tour pour mettre la vanne dans la position d'eau froide.

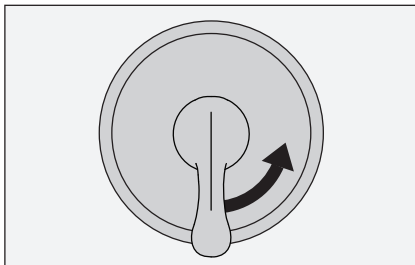

2) Tournez la poignée de douche dans le sens contraire des aiguilles d'une montre approximativement 1/2 de tour pour mettre la vanne dans la position d'eau tiède.

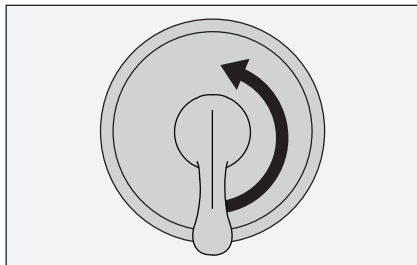

3) Tournez la poignée de douche dans le sens contraire des aiguilles d'une montre approximativement 3/4 de tour pour mettre la vanne dans la position d'eau chaude.

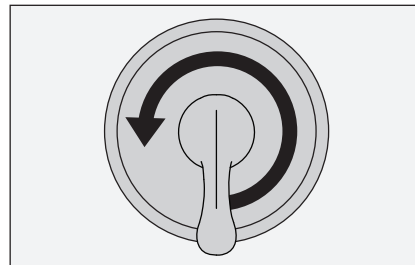

## Fonctionnement (Contrôle de dérivation)

1) Le levier de dérivation dans la position vers le bas pour le fonctionnement du bec de baignoire.

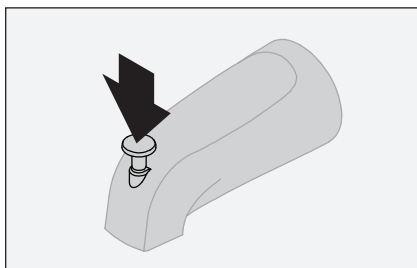

2) Le levier de dérivation dans la position vers le haut pour le fonctionnement de la douche.

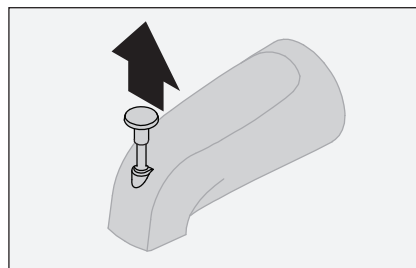

## Tableau de résolution des problèmes

Symptôme	Cause	Solution
Le fini est tâché.	Les éléments dans l'alimentation en eau peuvent causer des tâches sur le fini.	Nettoyez la boiserie avec un chiffon doux en utilisant un savon doux et de l'eau ou un nettoyant non abrasif et rincez rapidement avec de l'eau.