

SWINGING HANGER

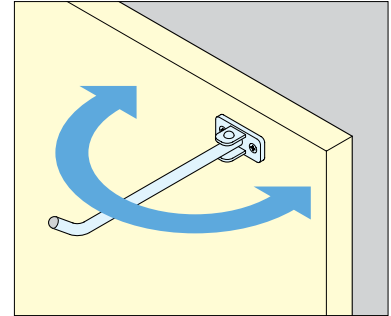

HM-250Y

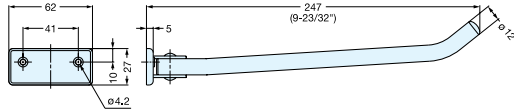

| Item No. | Load Capacity (kg) | Weight (g) | Box (pcs) | Carton (pcs) | Material | Finish |
|----------|--------------------|------------|-----------|--------------|---------------------|--------|
| HM-250Y | 3 (6.6 lbs) | 125 | 10 | 100 | 304 Stainless Steel | Satin |

SWINGING HANGER



HM-250V

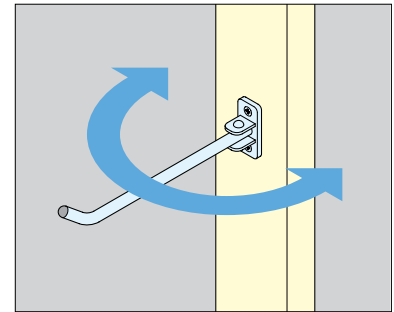
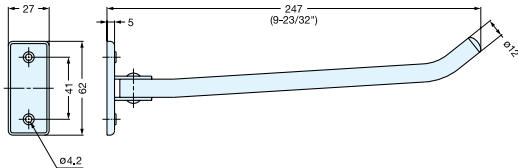

| Item No. | Load Capacity (kg) | Weight (g) | Box (pcs) | Carton (pcs) | Material | Finish |
|----------|--------------------|------------|-----------|--------------|---------------------|--------|
| HM-250V | 3 (6.6 lbs) | 120 | 10 | 100 | 304 Stainless Steel | Satin |

SWINGING HANGER



HM-330

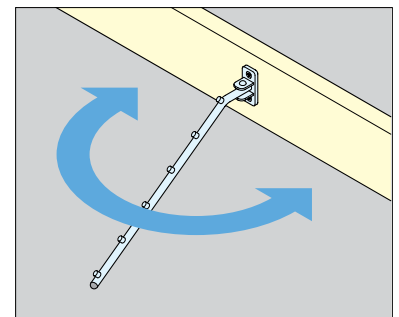
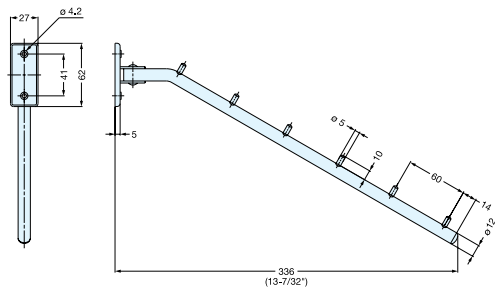

| Item No. | Load Capacity (kg) | Weight (g) | Box (pcs) | Carton (pcs) | Material | Finish |
|----------|--------------------|------------|-----------|--------------|---------------------|--------|
| HM-330 | 3 (6.6 lbs) | 170 | 10 | 100 | 304 Stainless Steel | Satin |