

FOLDING BRACKET

LOAD CAPACITY
150 kg
330 lbs

NSF
COMPONENT

NO SCREW

STAINLESS 304 STEEL

EB-303/EP

- Automatically locks when flap is in opened position.
- Depress lever to release the lock.
- Bracket with hinge function in one unit.

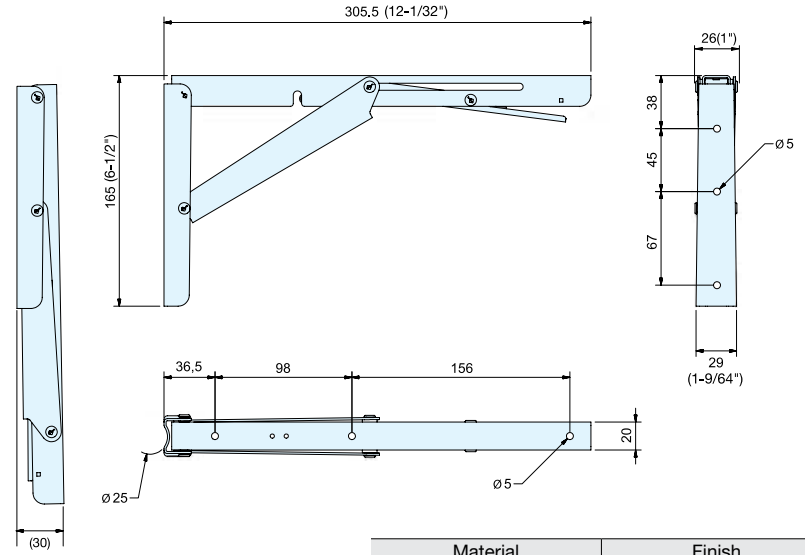
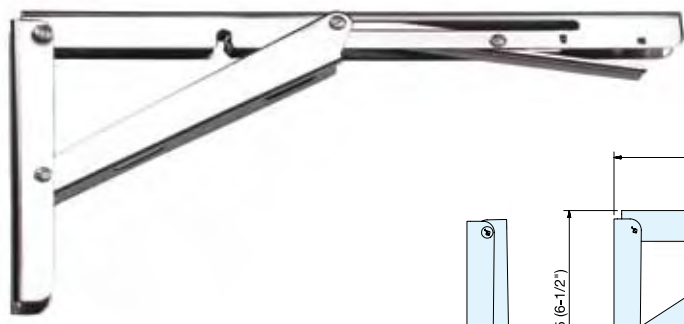

Material	Finish
304 Stainless Steel	Electro Polished

Item No.	Load Capacity (kg)	Weight (g)	Carton (pcs)
EB-303/EP	150 (330 lbs)/pc	515	25

Installation

