

PRODUCT DESCRIPTION

Clear slabs of glass a half inch thick are pressed together between two discs finished in Natural Aged Brass. As the glass approaches the center, each slab of glass increases in dimension creating a gradation of light revealing the glasses' shape and character. Dedicated LED lighting emits from concealed polycarbonate tubes evenly distributing the light source in all directions. These LED tubes terminate at brass discs supported by Dark Brown leather straps that both suspend the pendants and conceal the electrical wiring stitched within them. Elevate your lighting to the next Stratum integrating bygone modern design elements with innovative technologies and expert craftsmanship.

MEASUREMENTS

DIMENSION : 10" W x 10" H x 2.25" Ext
 CANOPY : 6" W x 1" H x 6" L
 HANGING WEIGHT : 4.9 lb

LAMPING

INPUT VOLTAGE : 120V
 LUMENS : 450 Rated (320 Del.)
 BULB : LED PCB Integrated , 10W Total
 BULB INCLUDED : (Integrated)
 DIMMABLE : Y
 CRI : 90 CRI
 COLOR_TEMP : 3000K
 LIGHTING_DIRECTION : OMNI

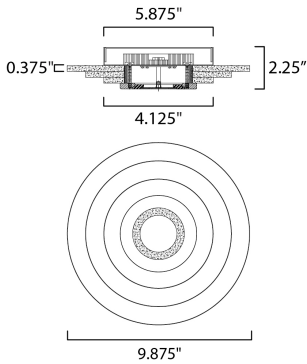

FINISHES OPTION

 Natural Aged Brass

GLASS

Clear CL

MATERIAL

Steel + Aluminium + PU Leather

RATINGS

cETLus
 Damp Location
 ADA



ADDITIONAL

INSTALL UP/DOWN: BOTH
 SLOPE:
 RATED LIFE 25000 Hours
 OPERATING TEMPERATURE:
 -20°C (-4°F), 40°C (104°F)

Always consult a qualified electrician before installing any lighting product.



Modifications or Customizations: Please email contract@studiomlighting.com
Sample Request: Please email order@studiomlighting.com with subject line "Sample Order_ [Project Name] / [Specifier/Designer]"
 All samples are subject to Studio M approval and must show proof of project and/or explanation.

Job Name:	Job Type:
Quantity:	Comments: