

SPEAKMAN®

SM-5430

Installation, Operation & Maintenance Instructions

SENTINELPRO™ COMBINATION SERIES

DESCRIPTION

Speakman SentinelPro™ Combination, SM-5430, unites Anti-Scald Thermostatic / Pressure Balance Diverter Shower/Bath Valve with integral Check Stops (CPV-TP-DV), Trim with integral Volume Control / Diverter Handle (CPT-5401), Shower Arm with Wall Flange (S-2500), Low Flow Single Function Shower Head (S-2272-E2), and Tub Spout (S-1554).

SPECIFICATIONS

CPV-TP-DV ANTI-SCALD THERMOSTATIC / PRESSURE BALANCE DIVERTER SHOWER VALVE:

CONNECTIONS: ½" Female Copper Sweat and ½" NPT Male at both the Inlets (Cold, Hot) & Outlets (Shower, Tub)

FLOW RATE: 1.5 gpm (5.7 L/min) or higher

COMPLIANCE: ASSE 1016 / ASME A112.1016 / CSA B125.16 & ASME A112.18.1 / CSA B125.1 Standards

CPT-5401 T/P DIVERTER VALVE TRIM:

FINISH: Polished Chrome

COMPLIANCE: ASME A112.18.1 / CSA B125.1 Standard

S-2500 SHOWER ARM WITH WALL FLANGE:

CONNECTIONS: ½" NPT Male Inlet & Outlet

FINISH: Polished Chrome

S-2272-E2 LOW FLOW SINGLE FUNCTION SHOWER HEAD:

CONNECTIONS: ½" NPT Female Inlet

FLOW RATE: 2.0 gpm (7.6 L/min)

FINISH: Polished Chrome

COMPLIANCE: ASME A112.18.1 / CSA B125.1 Standard & WaterSense Certified

S-1554 TUB SPOUT:

CONNECTIONS: ½" NPT Female Inlet

FINISH: Polished Chrome

INSTRUCTIONS

See individual products for installation of the components and warranty information.

SPEAKMAN®

ROUGH-IN

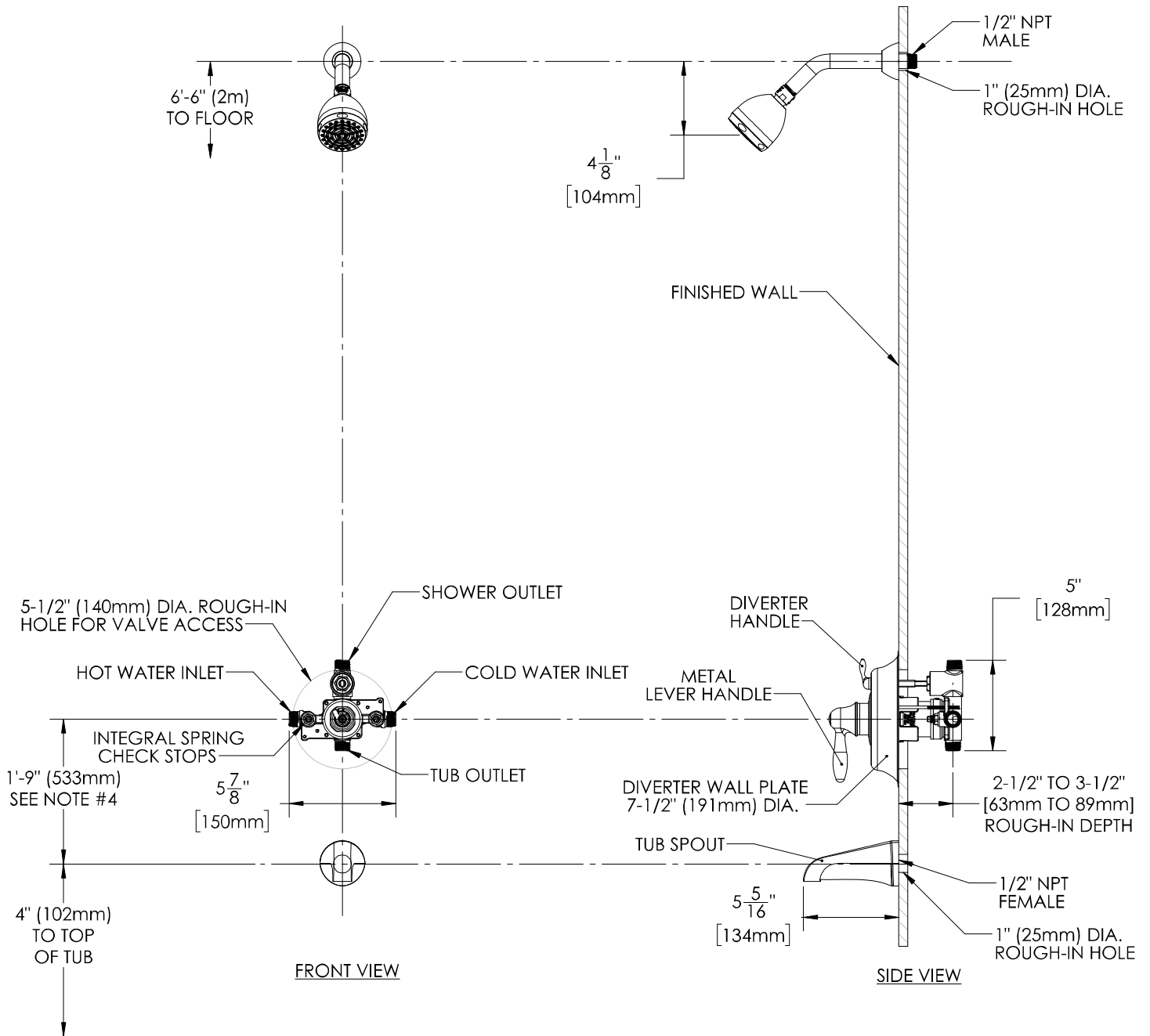

NOTES:

1. ALL DIMENSIONS ARE IN INCHES (MILLIMETERS) UNLESS OTHERWISE SPECIFIED AND ARE SUBJECT TO CHANGE WITHOUT NOTICE.
2. ALL INLETS AND OUTLETS ARE 1/2" FEMALE COPPER SWEAT AND 1/2" MALE NPT UNLESS OTHERWISE SPECIFIED.
3. FOR ADA MOUNTING LOCATIONS CONSULT ADAAG, ANSI A117.1, OR STATE REGULATIONS.

SPEAKMAN®

INSTRUCTIONS FOR MODELS

CPV-TP
CPV-TP-DV

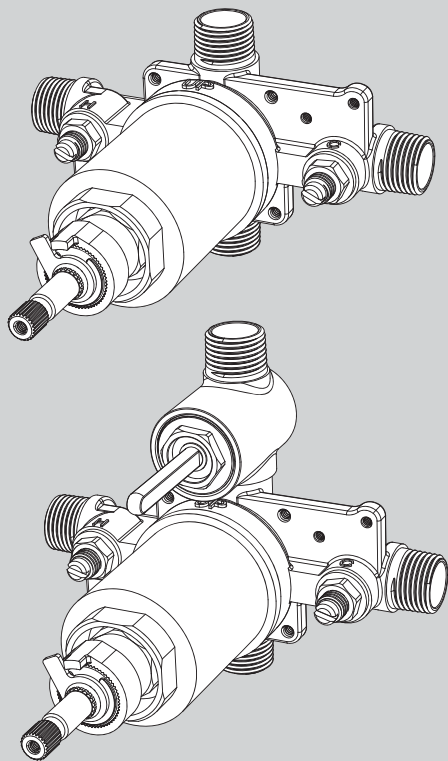

NEED HELP?

For additional assistance or service please contact:

SPEAKMAN® Company
400 Anchor Mill Road
New Castle, DE 19720

800-537-2107

customerservice@speakman.com

www.speakman.com

92-CPV-TP-02

TOOLS AND SUPPLIES

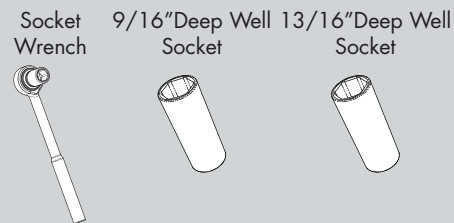
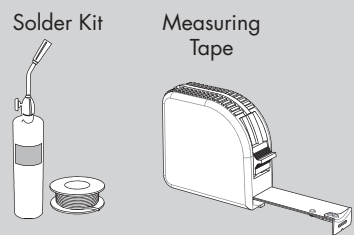
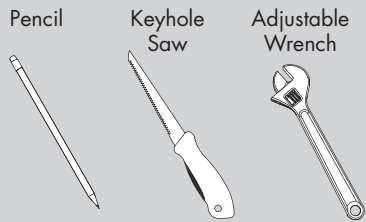

HELPFUL TOOLS & SUPPLIES:

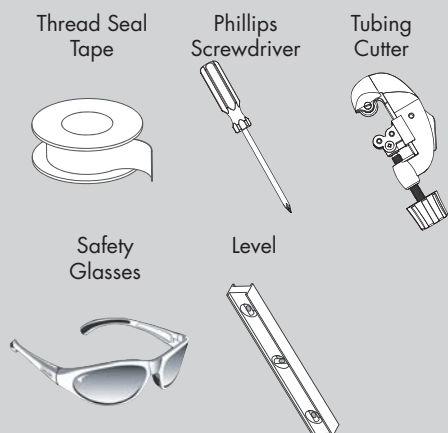

IMPORTANT

- Be sure to read instructions thoroughly before beginning installation.
- Be sure to have properly adjusted the Temperature Limiting Stop (TLS) as outlined in this Installation Manual.
- Inspect all connections after installation of valve.
- This valve has an operating range of 20-80 Psi.
- This valve is designed to be used in conjunction with a shower-head rated at 1.5 gpm (5.7 L/min) or higher flow rate.
- **NOTE:** This installation manual covers several models of valves. While the appearance of your valve may differ from those shown, the installation method is the same.
- Maximum water pressure: 125 PSI static; minimum water pressure: 20 PSI flowing; minimum cold supply temperature: 40° F; maximum hot supply temperature: 160° F; minimum hot supply temperature: 5° F above set point.

SAFETY TIPS

Cover your drain to prevent loss of parts. Be sure to wear eye protection while cutting pipe.

MAINTENANCE

Your new Shower/Bath Valve is designed for years of trouble-free performance. Keep it looking new by cleaning it periodically with a soft cloth. The use of harsh chemicals and abrasives on any of the Speakman custom finish products may damage the finish and void the product warranty. Please be sure to only use approved cleaners. Please contact Speakman for any clarification of acceptable cleaners.

This type of valve must be cleaned and maintained on a regular basis. Periodic maintenance should be performed at least every 12 months or after any changes have been made to the building's plumbing system. This maintenance should include removing and cleaning the spring check stop components. Make sure the stop poppet in each stop moves freely. The Lower Cartridge Seal with Integral Screens (located at the base of the Valve Cartridge) should be removed and cleaned during this maintenance cycle. Valves that are installed outdoors should be winterized by removing all of the internal parts and removing any standing water from the valve. Quarterly the maximum hot temperature setting (TLS) should be checked and adjusted accordingly.

WARRANTY

Additional warranty information can be found at: www.speakman.com

1 Referencing the supplied rough-in dimensions (located at the end of this manual), determine the preferred location of valve. Align the supplied rough-in template with this location and trace outline of template onto wall.

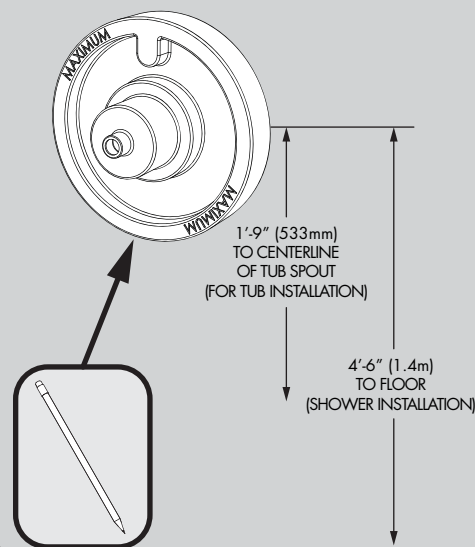

2 Using a keyhole saw or similar tool, cut along traced line and remove this section of wall.

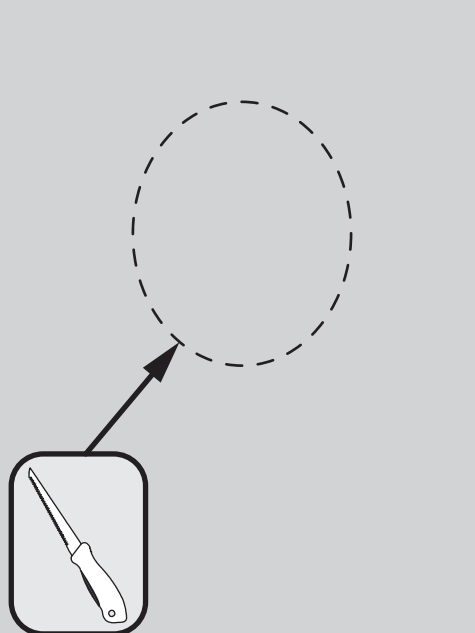

3 Unthread and remove the Integral Stops using a socket wrench equipped with a 9/16\" deep well socket.

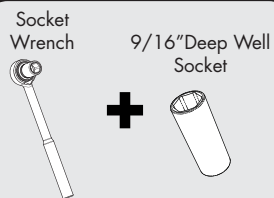
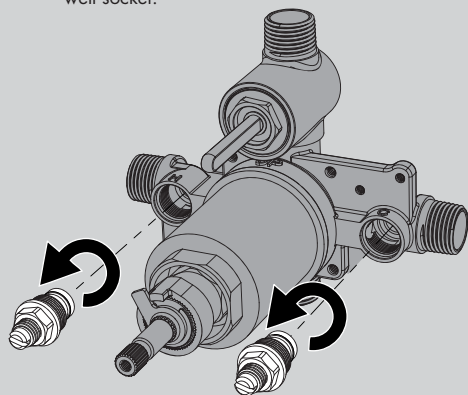

4 If your Shower Valve is equipped with an integral diverter, remove the Diverter Nut using a socket wrench and a 13/16\" deep well socket. Remove Diverter Cartridge to prevent damage during soldering.

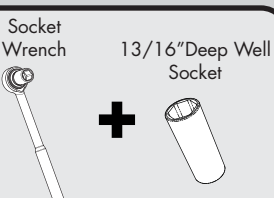
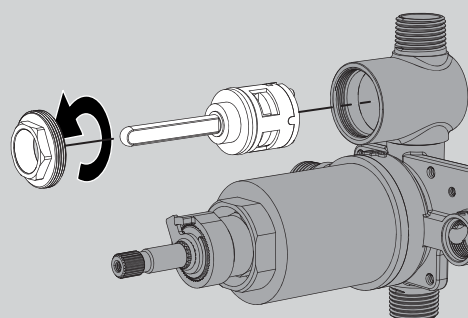

5 Install the Rough-In Template over the Shower Valve being sure the Rough-In Template sits flush against Shower Valve Bonnet. Following the rough-in dimensions for your model of valve (located at the end of this manual) as well as the markings on the supplied rough-in template, install valve at proper depth. The distance from the centerline of the inlet/outlet ports of the valve assembly to the finished wall **MUST** be between **2½\" - 3½\"**. See images below for reference.

MINIMUM MOUNTING DEPTH

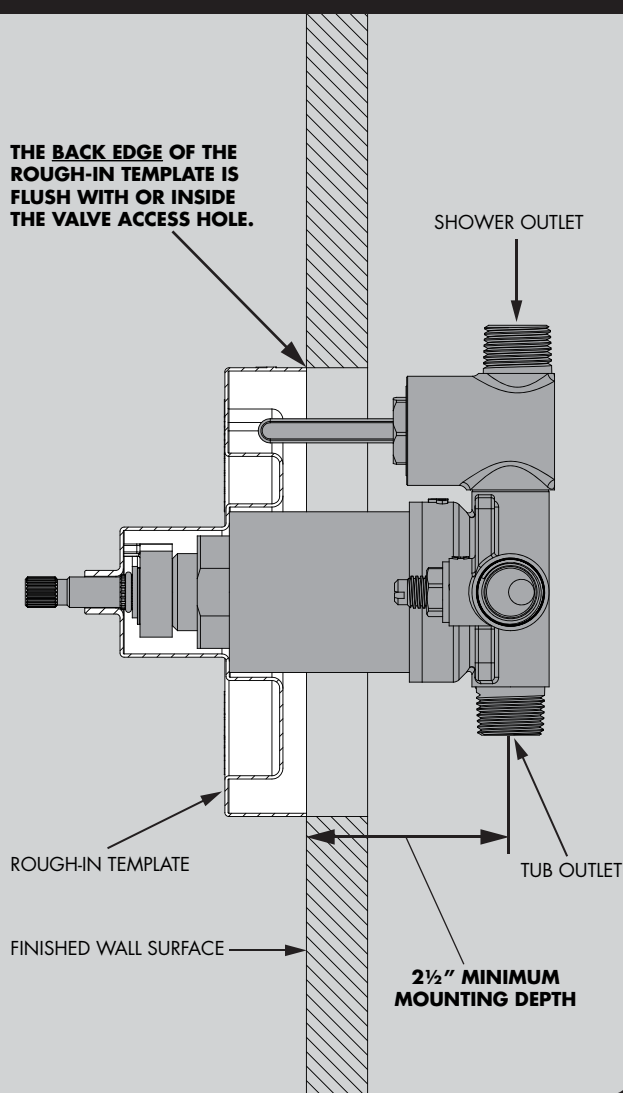

MAXIMUM MOUNTING DEPTH

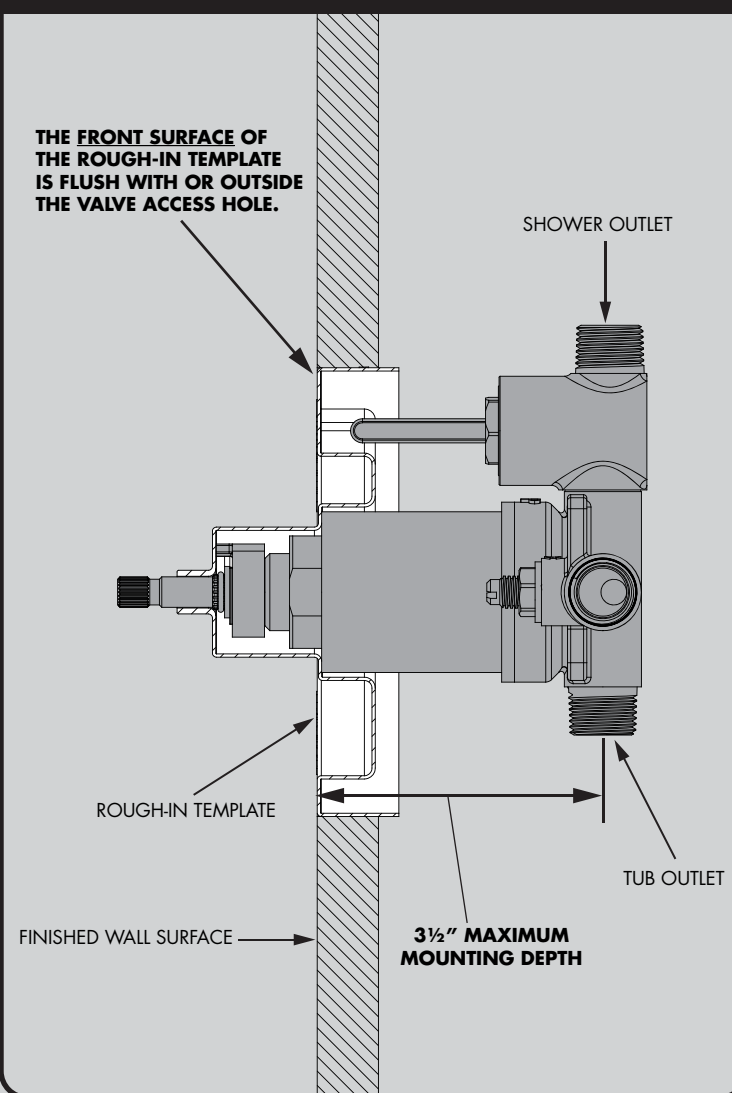

6 If your installation is for a shower only, apply thread seal tape to the lower outlet port and install the included cap. Wrench tighten.

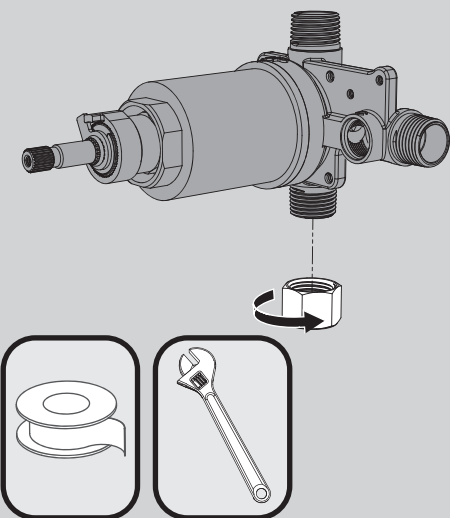

7 Ensure Valve is positioned plumb and level. Remove Rough-In Template from Valve. Make threaded connections or plumb and solder all joints and fittings. Take care to protect surrounding area when soldering. Secure piping to surrounding structure.

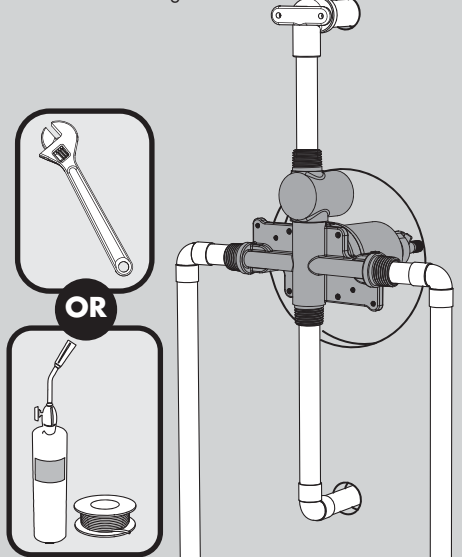

8 Make piping connections for all accessories. Take care to protect surrounding area when soldering. Secure piping to surrounding structure.

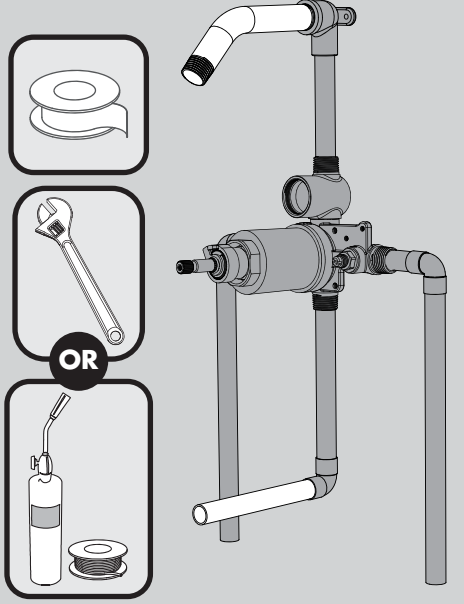

9 Reinstall the Integral Stops using a Socket Wrench equipped with a 9/16" Deep Well Socket or Crescent Wrench.

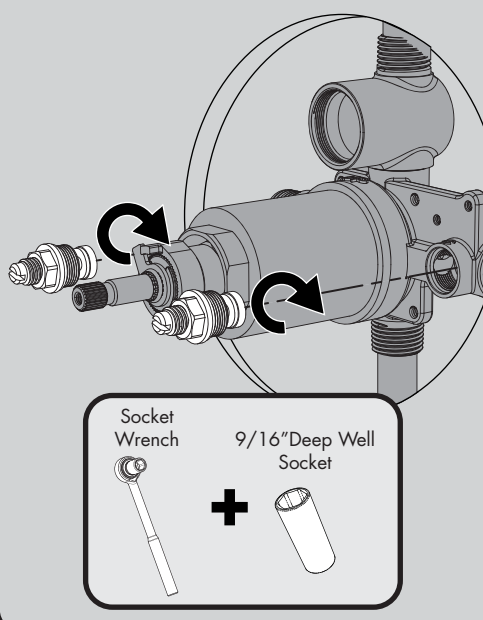

10 If your Shower Valve is equipped with an integral diverter, reinstall the Diverter Cartridge taking care to align mounting posts of cartridge with the corresponding holes in the diverter valve body. Install Diverter Nut and tighten with a Socket Wrench and 13/16" Deep Well Socket. Take care to not over-tighten connections.

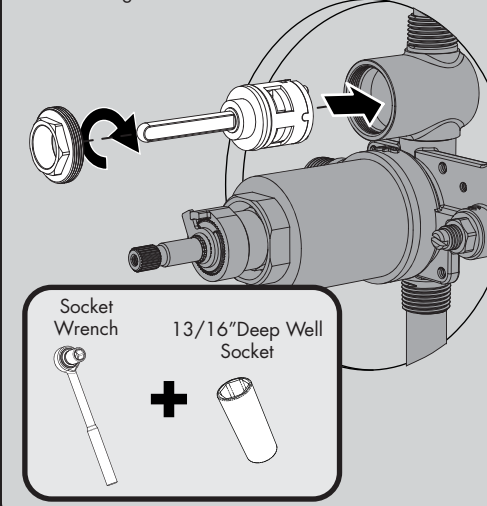

11 Your Shower Valve has the ability to be mounted back-to-back with another Valve in a shared space. This means the hot and cold inlets may be reversed. Please see the following steps to adapt your valve for back-to-back mounting or reversed inlet supplies.

If you are performing a **Standard Installation**, please proceed to **Step 14**

OR

If you are performing a **Back to Back Installation**, or have reversed inlet supplies, please proceed to **Step 12**

12 BACK-TO-BACK INSTALLATION STEP 1

To adapt your shower valve for back to back installation, use an adjustable wrench to unthread and remove the Bonnet **1**. Then remove Cartridge Assembly **2**, and Bonnet O-Ring **3** from valve body.

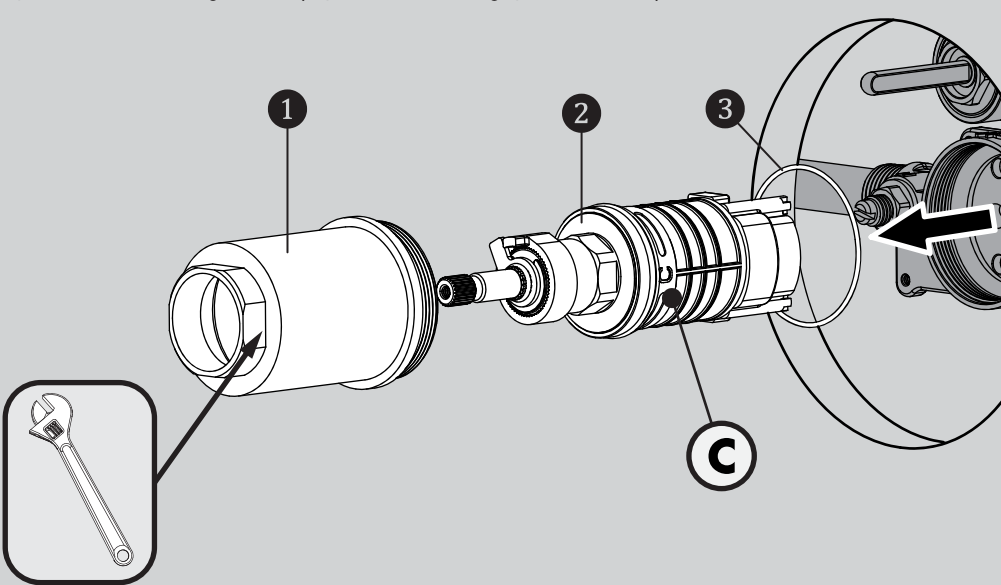

13 BACK TO BACK INSTALLATION STEP 2

Rotate Valve Cartridge **2** 180° and reinstall into Valve Body taking care to properly align the mounting posts of the Cartridge with the corresponding holes within the Valve. The "H" marking on Valve Cartridge cover should now be on the right hand side. Reinstall Bonnet **1**, making sure the Large Bonnet O-Ring **3** is in place within the Valve Body.

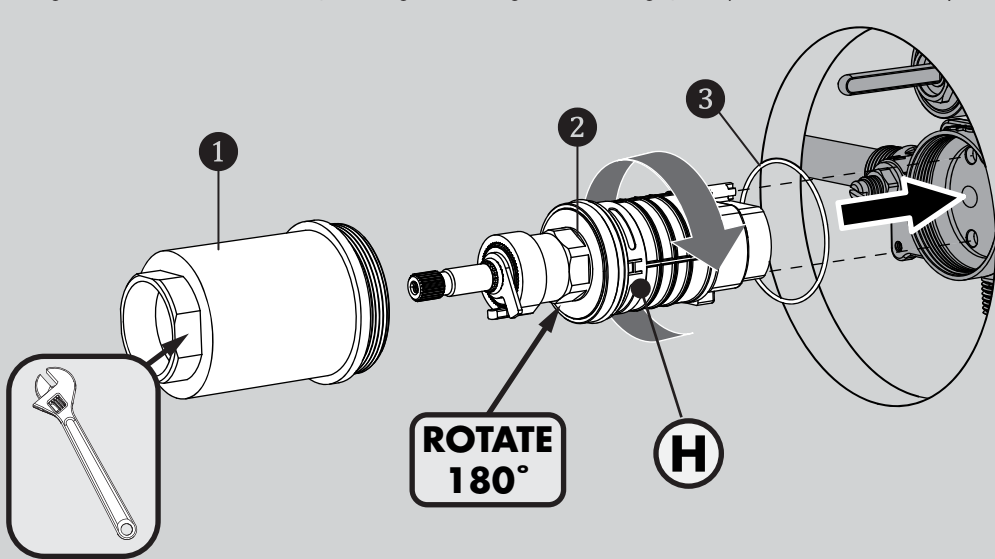

14 Ensure the Valve is in the "OFF" position. Turn "ON" water supplies and check all connections for leaks.

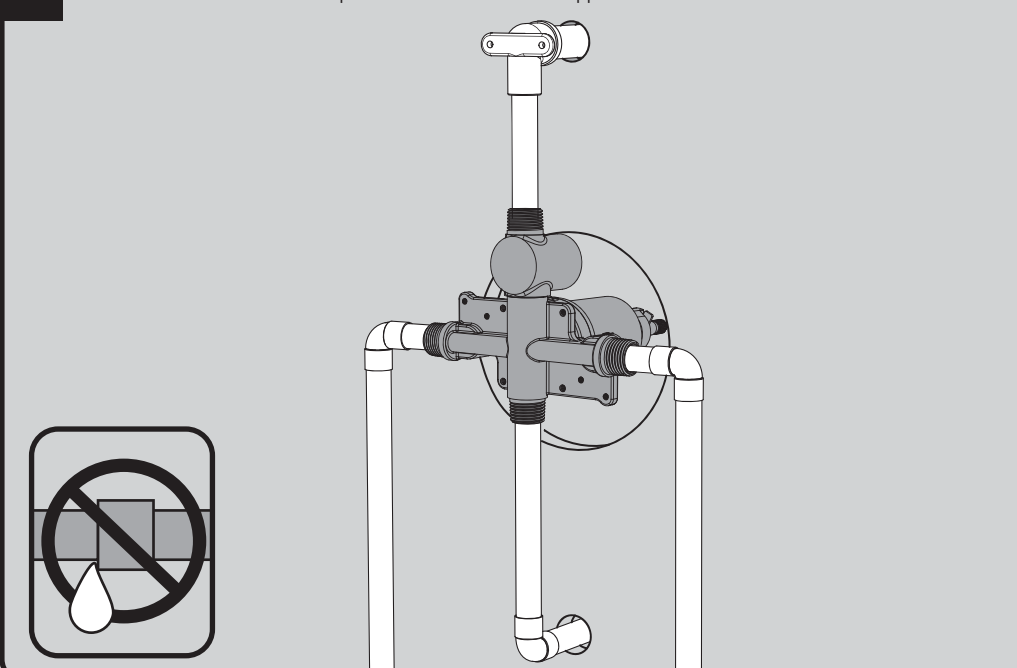

15 TEMPERATURE LIMIT ADJUSTMENT

The maximum hot water temperature setting adjustment (Temperature Limit Stop (TLS)) of the valve has been factory set at 110° F. Important- Check each valve installation with a thermometer to make sure the maximum hot water temperature is set to the recommended setting of 110° F maximum. To lower the limit of the maximum hot water temperature the valve delivers, adjust the valve's temperature limit stop (TLS) plate.

- Slip the retaining O-ring and the TLS plate towards the end of the spindle.
- With the water supplies on, rotate the valve spindle clockwise to the maximum desired hot water temperature.
- Position the TLS plate so it contacts the lug and therefore restricts the clockwise rotation of the spindle.
- Slip the retaining O-ring back into the groove of the spindle to hold the TLS plate in place.
- Rotate the spindle counter-clockwise to the "Off" position.

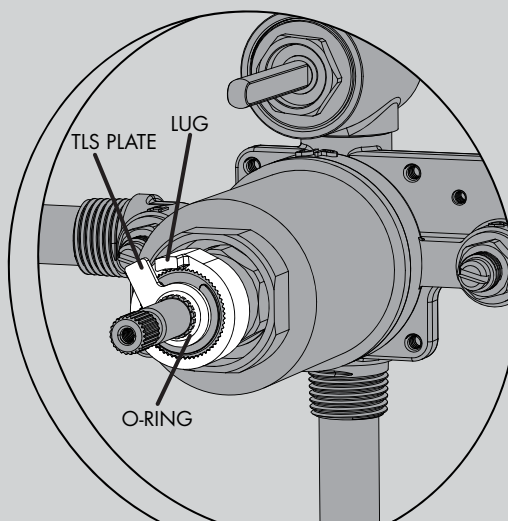

16 Reinstall Rough-In Template over Valve to protect it during final wall preparation.

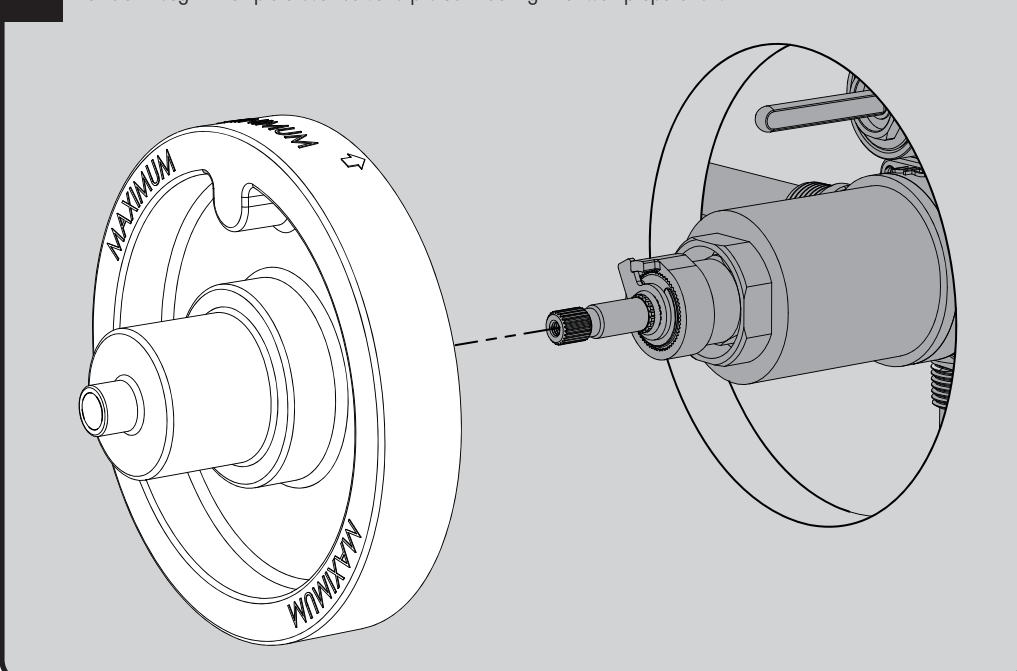

CPV-TP / CPV-TP-DV SERVICE INSTRUCTIONS

Service instructions

Caution- Any repair or servicing of the valve may affect the maximum hot temperature setting of the valve. After working on the valve, make sure the maximum hot water temperature is set to the recommended setting of 110° F maximum.

T/P Cartridge Removal

- 1) Shut off the hot & cold water supply integral stops at the valve. Remove valve trim from valve.
- 2) With the valve in the OFF position, remove the Bonnet by unthreading with an adjustable wrench. The cartridge may come out with the bonnet.
- 3) If necessary, remove the cartridge from the valve body by pulling on the valve spindle of the cartridge. Make sure the lower cartridge seal is installed in the bottom of the cartridge and not in the valve body. Inspect Lower Cartridge Seal with Integral Screens to verify they are debris free. If debris is present, remove Lower Cartridge Seal and clean Screen material.
- 4) Replace the necessary parts with new parts. When replacing the T/P cartridge, make sure that the Lower Cartridge Seal is properly installed in the recesses on the bottom of the cartridge. This Lower Cartridge Seal is positioned over the hot & cold inlet holes inside the body.
- 5) Make sure the large bonnet O-ring seal is installed and seated properly in the valve body. Reassemble the valve bonnet by threading it into the valve body with an adjustable wrench. Important- Adjust the valve's maximum hot water temperature to the recommended setting of 110° F. See Step #15 of the installation instructions for the TLS adjustment instructions.
- 6) Turn ON the hot & cold water supply integral stops. Check valve for leaks.
- 7) Reassemble the valve trim parts.

Spring Check Stop Parts Removal

- 1) Shut off hot and cold water supply valves to the integral stops of the valve. Remove valve trim from valve.
- 2) CLOSE integral stops by turning the stop spindles clockwise. Unscrew the stop's retaining nut with wrench. Carefully remove the retaining nut w/spindle, spring, and poppet assembly. Clean and/or replace the necessary parts. Reassemble the parts, reversing the above procedure. Repeat procedure on the other stop.
- 3) OPEN the integral stops by turning the stop spindles counter clockwise. Turn on the hot and cold water supply valves. Check for leaks.
- 4) Reassemble the trim parts.

CPV-TP / CPV-TP-DV REPAIR PARTS

SPEAKMAN®

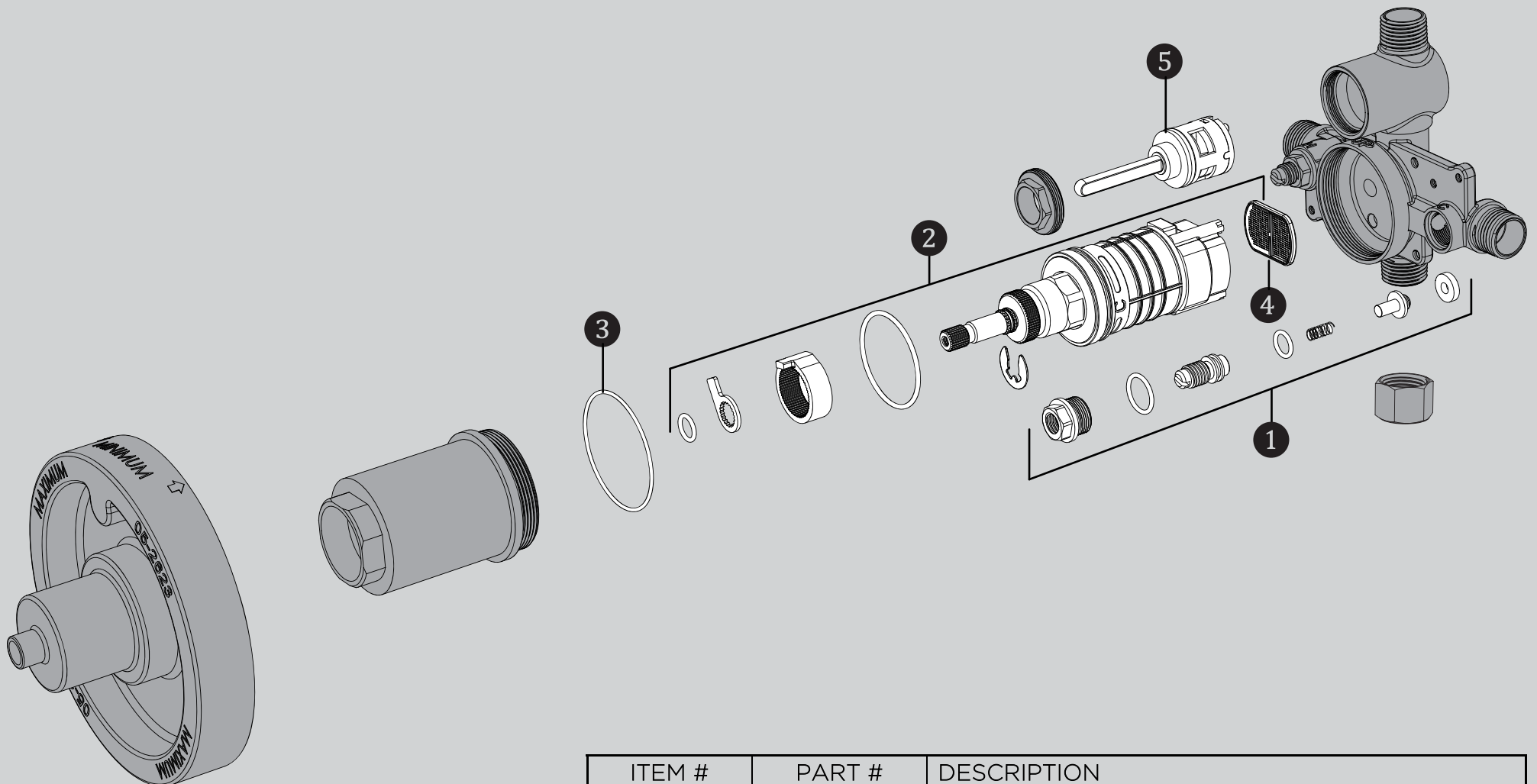

ITEM #	PART #	DESCRIPTION
1	RPG05-0862	CHECK STOP REPAIR KIT
2	RPG05-1109	T/P CARTRIDGE
3	RPG49-0012	BONNET O-RING
4	RPG49-0011	LOWER CARTRIDGE SEAL
5	RPG05-0897	VOLUME CONTROL/DIVERTER CERAMIC REPAIR CARTRIDGE

NOTES:

COMPLIANCE:

ASME A112.18.1/CSA B125.1

Shower Valve ASSE1016

CONNECTIONS:

Hot/Cold Inlets: 1/2" Female Copper Sweat
1/2" NPT Male

Shower Outlet: 1/2" Female Copper Sweat
1/2" NPT Male

Tub Outlet: 1/2" Female Copper Sweat
1/2" NPT Male
(Cap included for Shower Only Connections)

NOTES:

This valve is designed to be used in conjunction with a shower-head rated at 1.5 gpm (5.7 L/min) or higher flow rate

Contractor to supply necessary inlet connections.

DIMENSIONS SUBJECT TO CHANGE WITHOUT NOTICE. FOR ADA MOUNTING LOCATIONS, CONSULT ADAAG, ANSI A117.1, AND STATE REGULATIONS.

DIMENSIONS SUBJECT TO CHANGE WITHOUT NOTICE.

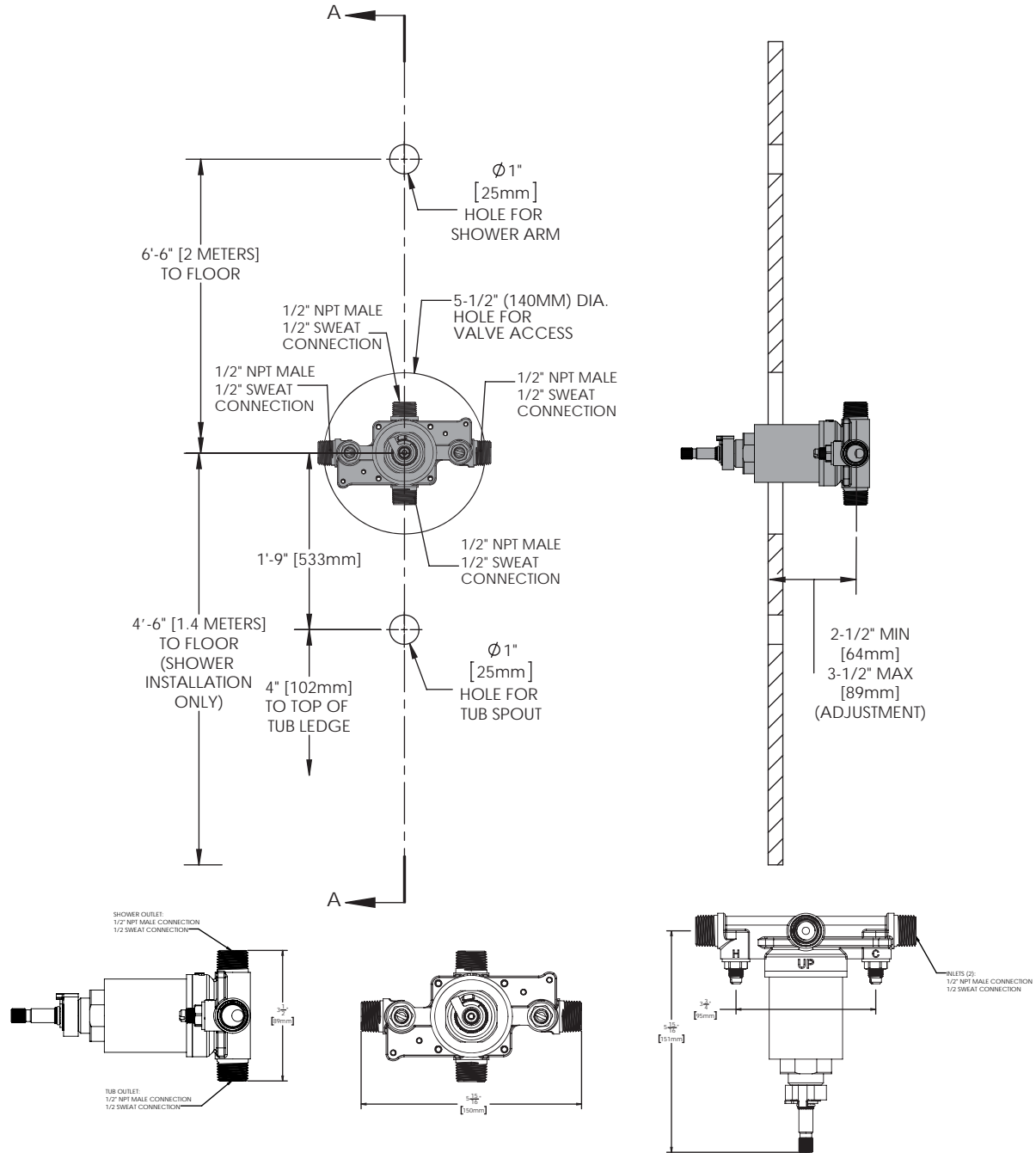

NOTES:

COMPLIANCE:

ASME A112.18.1/CSA B125.1

Shower Valve ASSE1016

CONNECTIONS:

Hot/Cold Inlets: 1/2" Female Copper Sweat
1/2" NPT Male

Shower Outlet: 1/2" Female Copper Sweat
1/2" NPT Male

Tub Outlet: 1/2" Female Copper Sweat
1/2" NPT Male
(Cap included for Shower Only Connections)

NOTES:

This valve is designed to be used in conjunction with a shower-head rated at 1.5 gpm (5.7 L/min) or higher flow rate

Contractor to supply necessary inlet connections.

DIMENSIONS SUBJECT TO CHANGE WITHOUT NOTICE. FOR ADA MOUNTING LOCATIONS, CONSULT ADAAG, ANSI A117.1, AND STATE REGULATIONS.

DIMENSIONS SUBJECT TO CHANGE WITHOUT NOTICE.

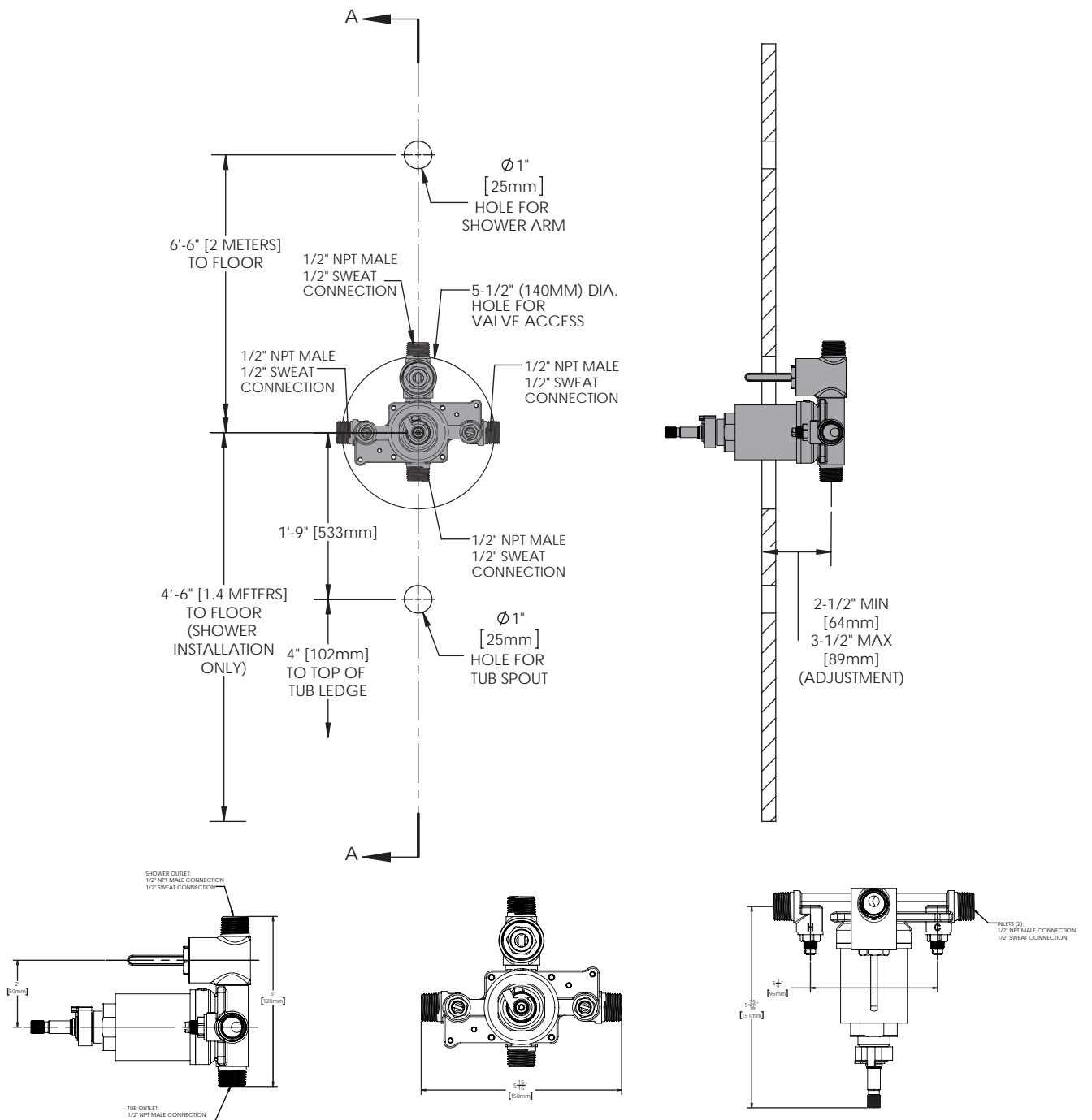

INSTRUCTIONS FOR MODELS

CPT-5001 / CPT-5401

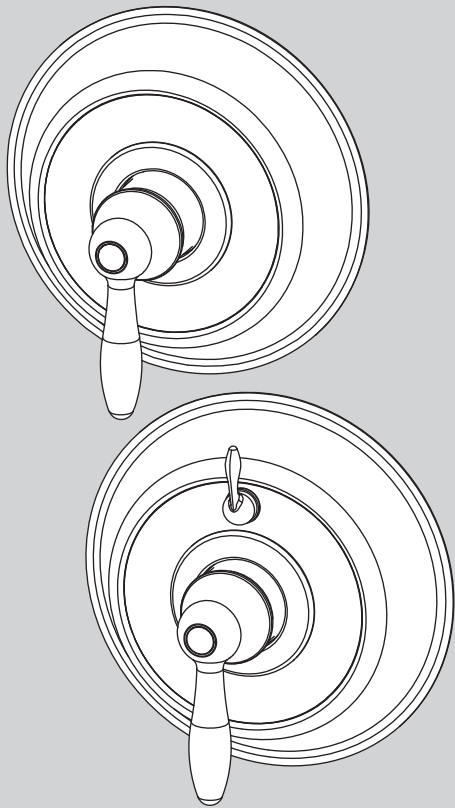

NEED HELP?

For additional assistance or service please contact:

SPEAKMAN® Company
400 Anchor Mill Road
New Castle, DE 19720

800-537-2107

customerservice@speakman.com

www.speakman.com

92-CPT-5001-01

TOOLS AND SUPPLIES

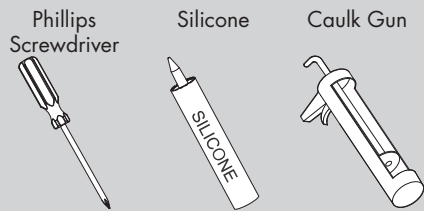

IMPORTANT

- Do not over-tighten any connections or damage may occur.
- Be sure to read instructions thoroughly before beginning installation.
- This valve has an operating range of 20-80 psi.

SAFETY TIPS

Cover your drain to prevent loss of parts. Be sure to wear eye protection while cutting pipe.

MAINTENANCE

Your new Speakman Product is designed for years of trouble-free performance. Keep it looking new by cleaning it periodically with a soft cloth. The use of harsh chemicals and abrasives on any of the Speakman custom finish products may damage the finish and void the product warranty. Please be sure to only use approved cleaners. Please contact Speakman for any clarification of acceptable cleaners.

WARRANTY

Additional warranty information can be found at: www.speakman.com

1 Remove the Handle Button Screw by inserting one of the included Mounting Screws thru the hole in the Handle.

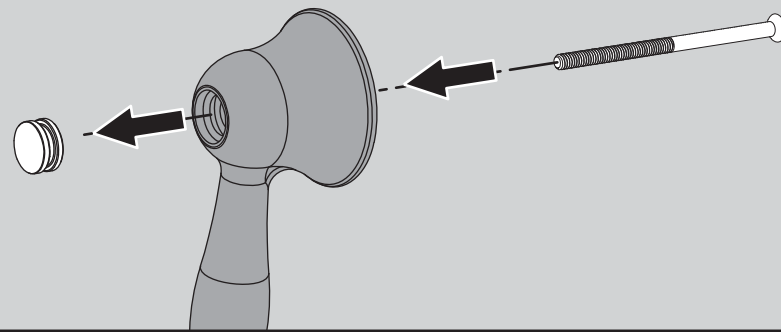

2 Insert the T/P Rubber Sleeve with Tabs over Valve Bonnet.

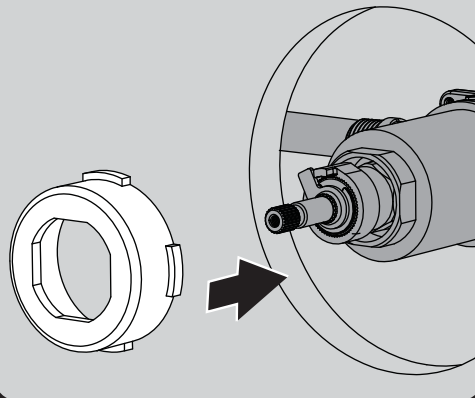

3 Be sure to have properly adjusted the Temperature Limiting Stop (TLS) as per the Valve Installation Instructions before installing Valve Trim. Slide Trim Sleeve over the Rubber Sleeve. Ensure the tabs are properly seated within the grooves of the Trim Sleeve.

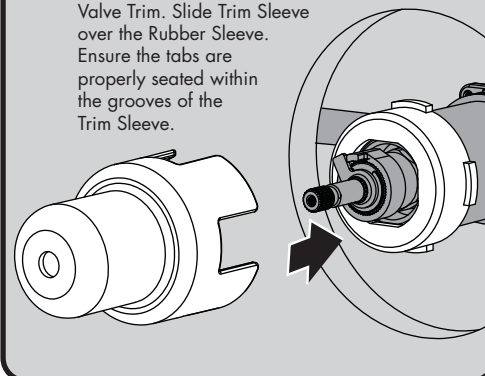

4 Clean wall surface. Orient Wall Plate as shown below. Apply clear silicone sealant to the backside outer flat surface of the Wall Plate, while leaving a small area open at the bottom. This will allow for any moisture to drain.

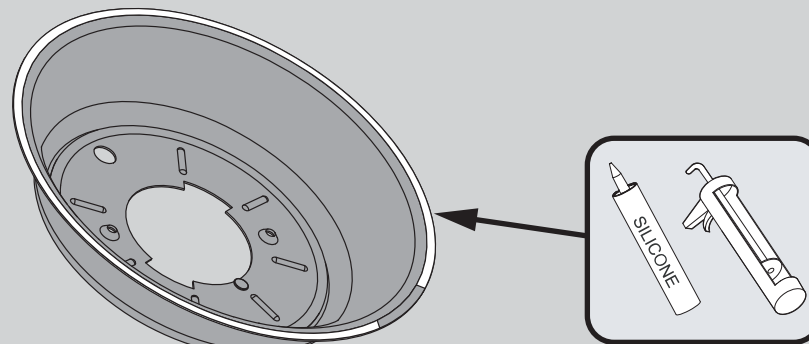

5A FOR CPT-5001 - Align the Wall Plate (1) as shown below. Secure to Valve with the included Mounting Screws (2). Take care to not over tighten Mounting Screws. Remove excess sealant after securing Wall Plate to wall.

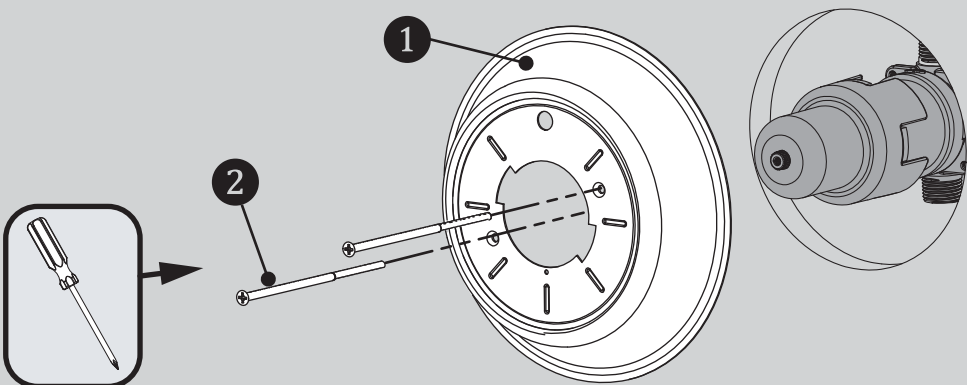

6 Remove protective film from Trim Index Plate.

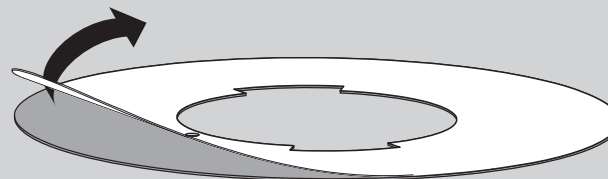

5B FOR CPT-5401 - Align the Wall Plate (1) as shown below. Verify the Diverter Valve Stem is in the OFF (vertical) position. Align the Diverter Drive Tube (3) on the Wall Plate to the Stem (4) of the Diverter Valve. Secure to Valve with the included Mounting Screws (2). Take care to not over tighten Mounting Screws. Remove excess sealant after securing Wall Plate to wall.

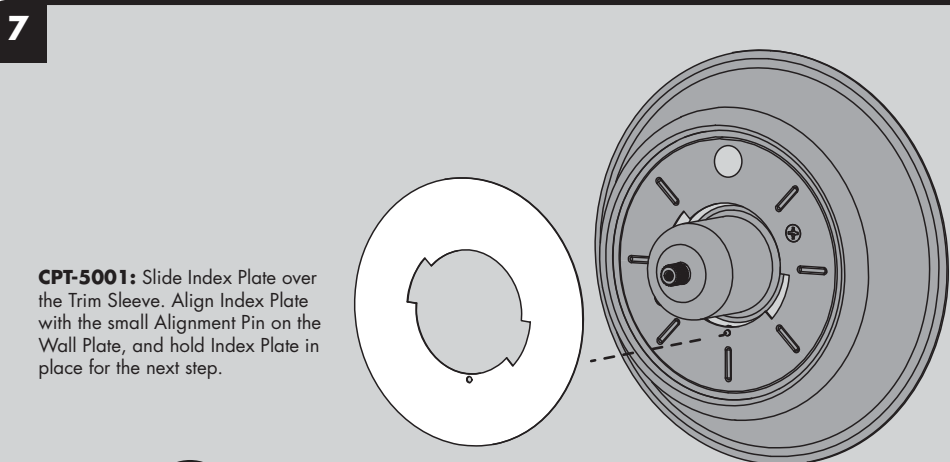
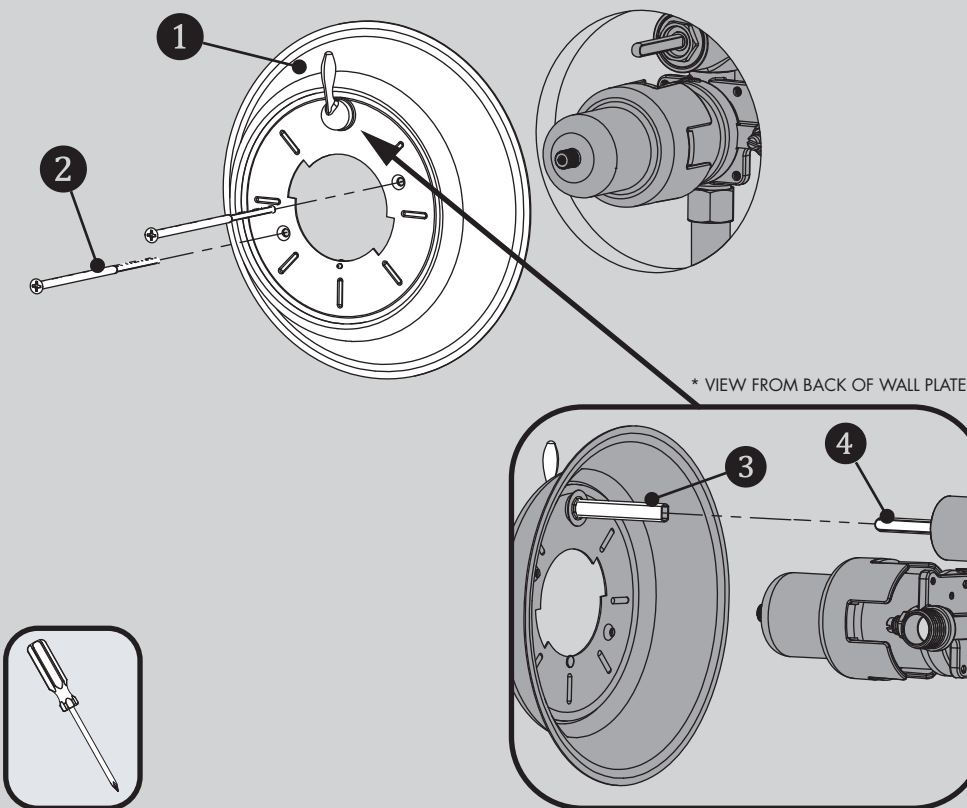

CPT-5001: Slide Index Plate over the Trim Sleeve. Align Index Plate with the small Alignment Pin on the Wall Plate, and hold Index Plate in place for the next step.

OR

CPT-5401: Slip the upper hole of the Index Plate over the Diverter Handle and then align the large hole of the Index Plate over the Trim Sleeve. Align Trim Index Plate with the small Alignment Pin on the Wall Plate, and hold Index Plate in place for the next step.

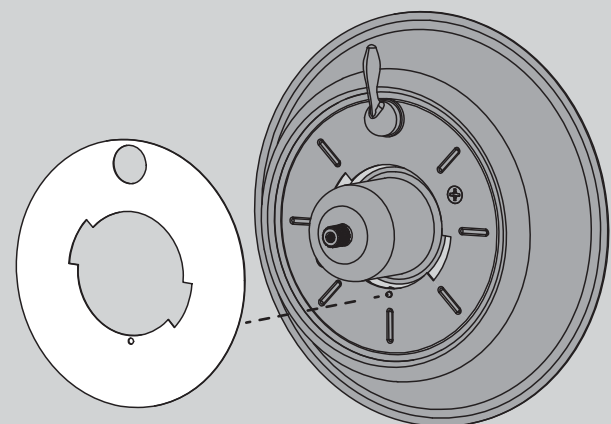

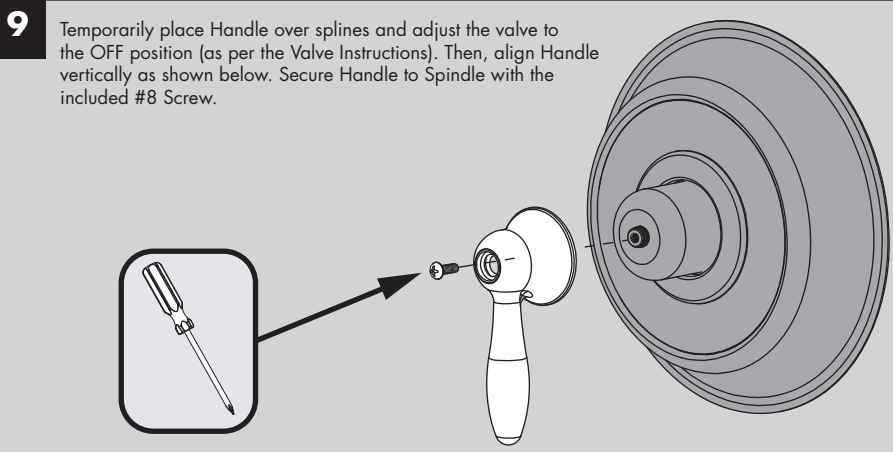
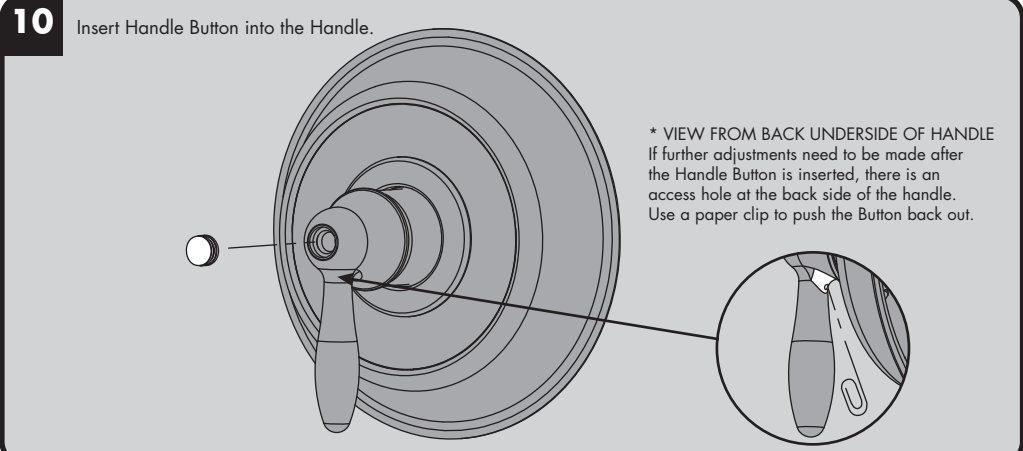
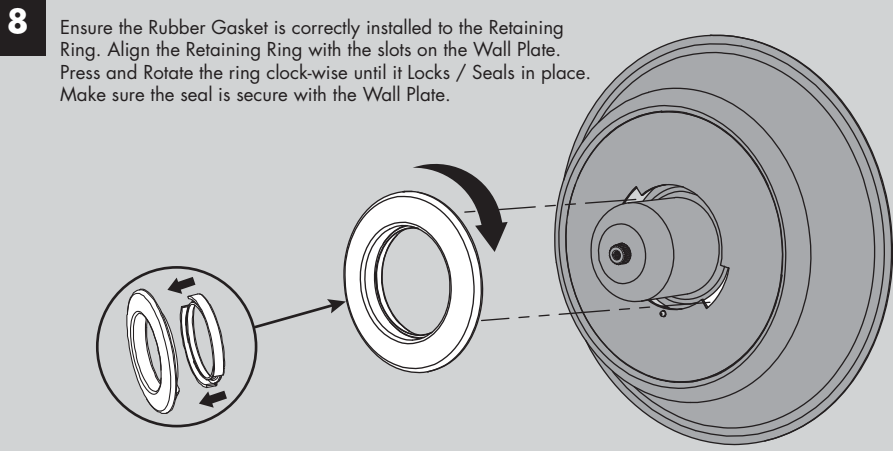

CPT-5001 / CPT-5401 REPAIR PARTS

SPEAKMAN®

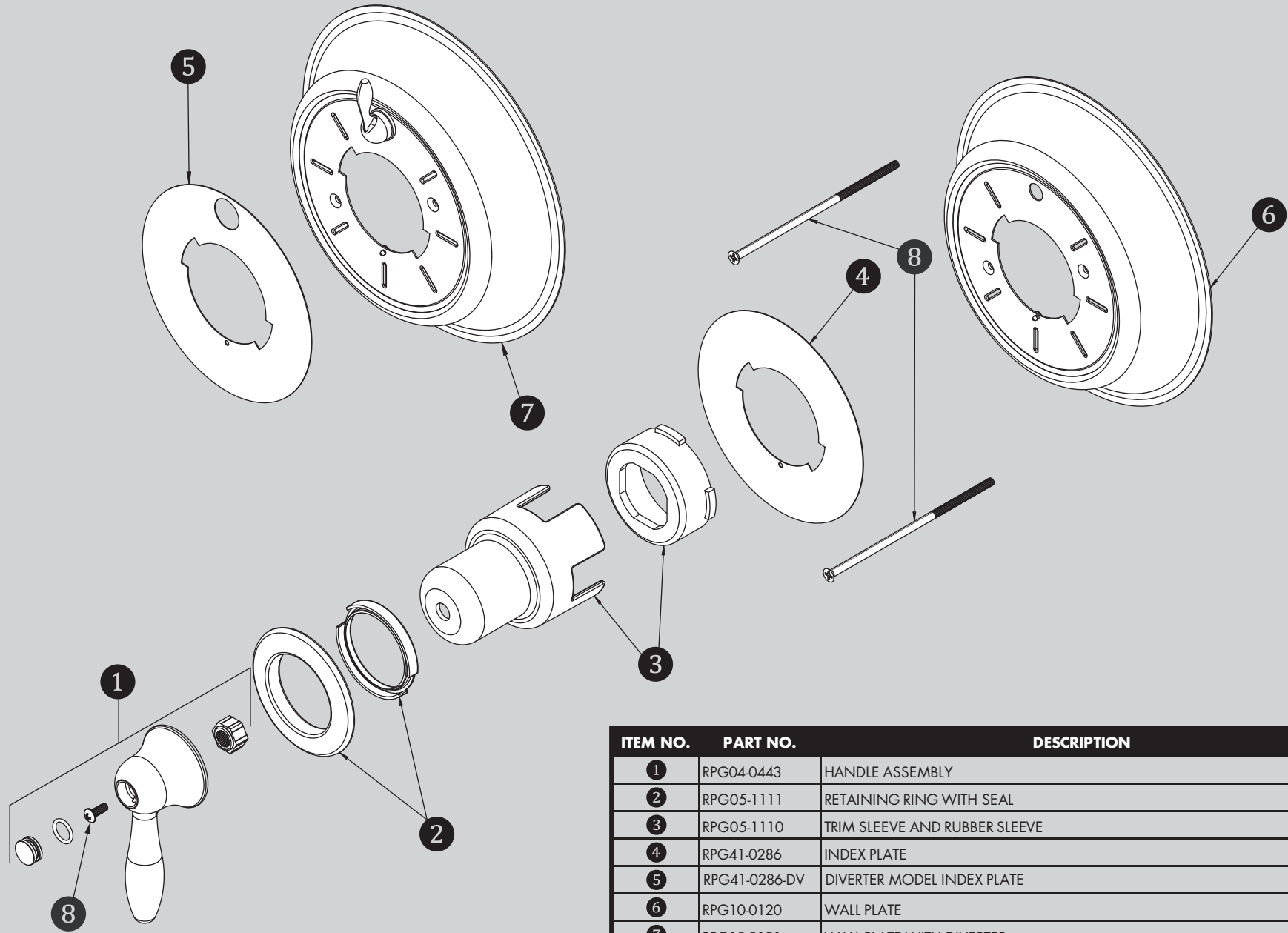

ITEM NO.	PART NO.	DESCRIPTION
1	RPG04-0443	HANDLE ASSEMBLY
2	RPG05-1111	RETAINING RING WITH SEAL
3	RPG05-1110	TRIM SLEEVE AND RUBBER SLEEVE
4	RPG41-0286	INDEX PLATE
5	RPG41-0286-DV	DIVERTER MODEL INDEX PLATE
6	RPG10-0120	WALL PLATE
7	RPG10-0121	WALL PLATE WITH DIVERTER
8	RPG10-0119	MOUNTING HARDWARE (ALL SCREWS)

CPT-5001 ROUGH-IN DIAGRAM

SPEAKMAN®

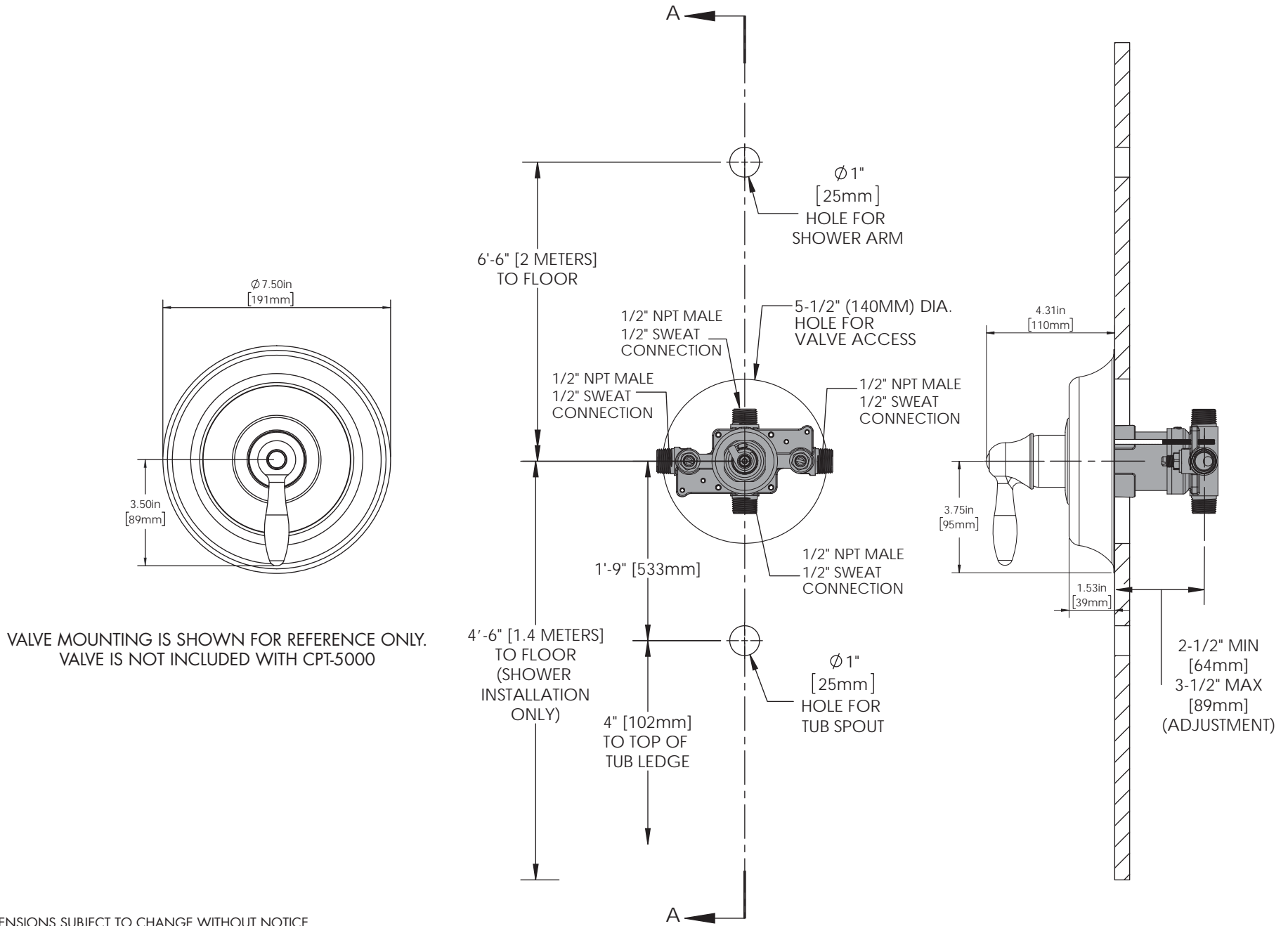

CPT-5401 ROUGH-IN DIAGRAM

SPEAKMAN®

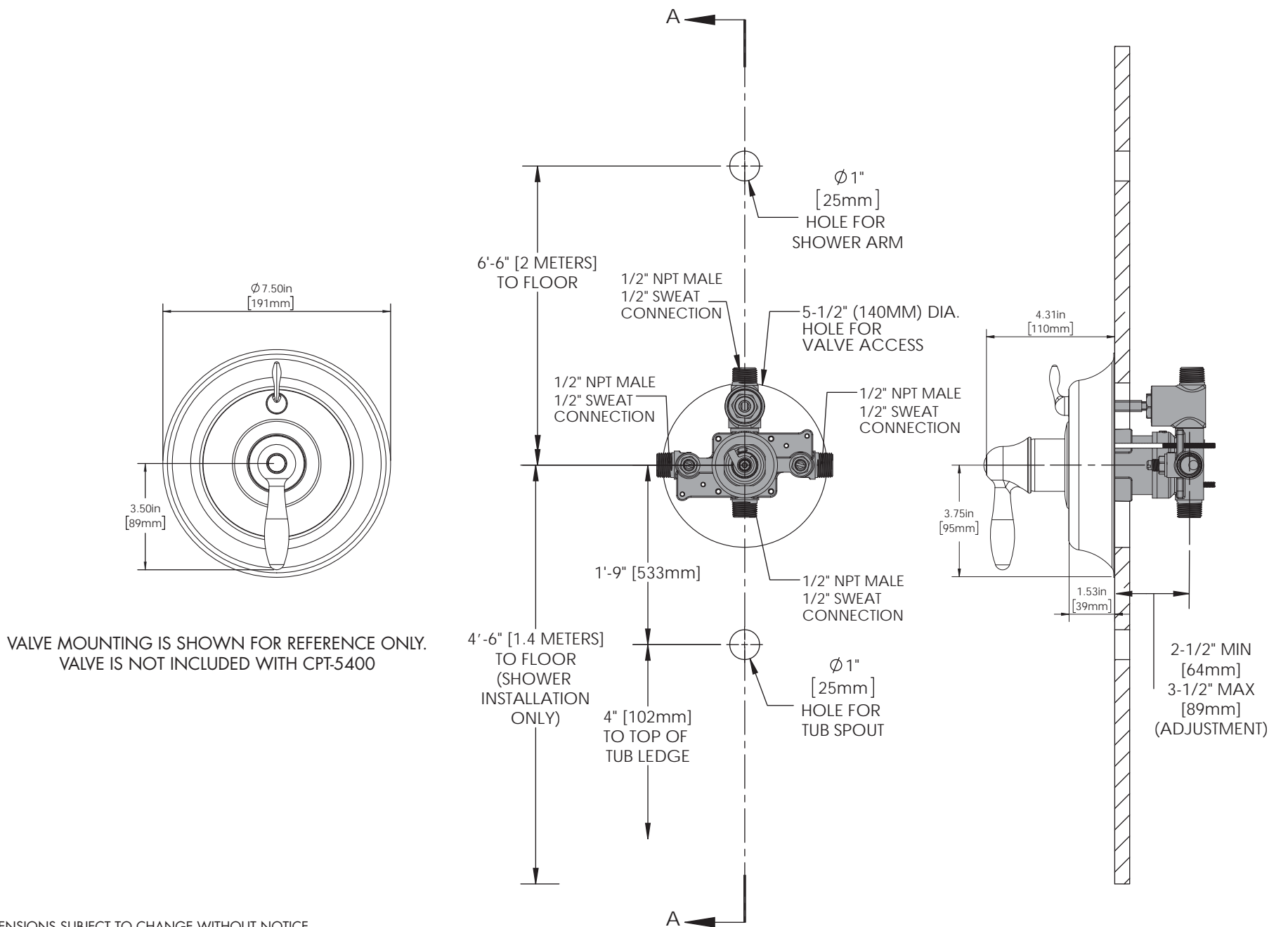

INSTRUCTIONS FOR MODELS

S-2500

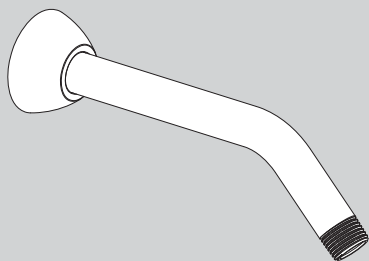

NEED HELP?

For additional assistance or service please contact:

SPEAKMAN® Company
400 Anchor Mill Road
New Castle, DE 19720

800-537-2107

customerservice@speakman.com

www.speakman.com

92-S-2500-R5

TOOLS AND SUPPLIES

Thread Seal
Tape



IMPORTANT



Be sure to read instructions thoroughly before beginning installation. Do not overtighten any connections or damage may occur.

SAFETY TIPS

Cover your drain to prevent loss of parts.

MAINTENANCE

Your new Shower Arm is designed for years of trouble-free performance. Keep it looking new by cleaning it periodically with a soft cloth. Avoid abrasive cleaners, steel wool and harsh chemicals as these will dull the finish and void your warranty.

WARRANTY

Additional warranty information can be found at:
www.speakman.com

- 1 Place the Escutcheon Plate (1) on a flat surface. Push the long end of the Shower Arm (2) down into the plate. This will help the teeth of the plate slide over the arm easier.

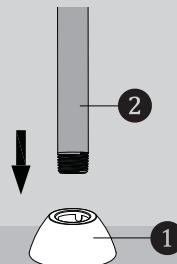

- 4 Position Escutcheon Plate (1) flat against wall.

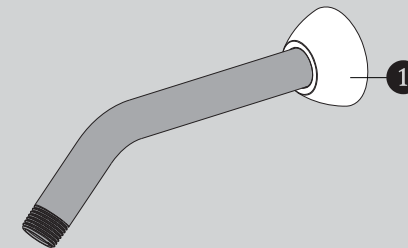

- 2 Once the Escutcheon Plate (1) is on the shower arm, slide the plate over the Shower Arm (2).

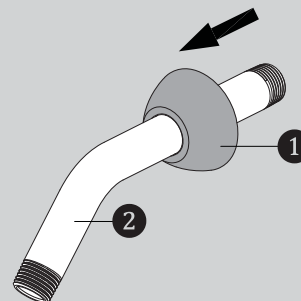

- 3 Apply Teflon Tape to inlet side of Shower Arm (2). Thread Shower Arm (2) into Female Pipe Fitting within the wall. Firmly tighten, and make sure Shower Arm (2) Outlet is pointing in a downward position.

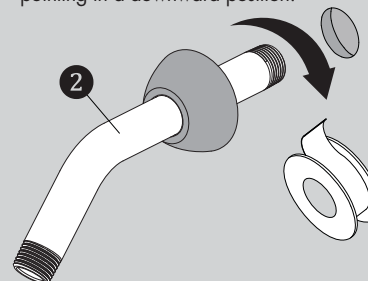

ROUGH IN DIMENSIONS

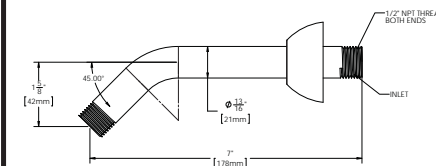
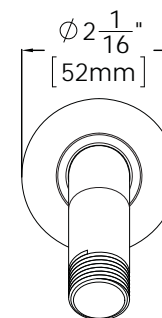

Specifications:

Supply Inlet: 1/2" NPT MALE

Outlet: 1/2" NPT MALE

INSTRUCTIONS FOR MODELS

S-2272-E2
S-2272-E15

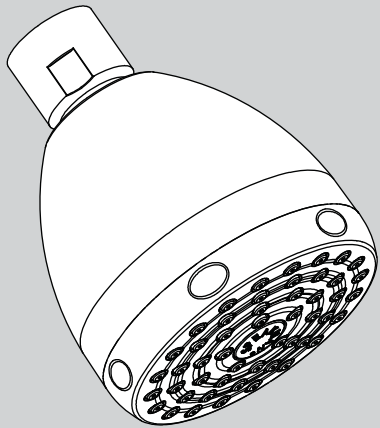

NEED HELP?

For additional assistance or service please contact:

SPEAKMAN® Company
400 Anchor Mill Road
New Castle, DE 19720

 800-537-2107

 customerservice@speakman.com

 www.speakman.com

92-S-2272-01

TOOLS AND SUPPLIES

Thread Seal
Tape



Adjustable
Wrench



IMPORTANT



Be sure to read instructions thoroughly before beginning installation. Do not overtighten any connections or damage may occur.

SAFETY TIPS



Cover your drain to prevent loss of parts.

MAINTENANCE



Periodic cleaning using a mild soap and warm water will help keep your Showerhead's appearance in its original condition.

For best results, dry immediately with a soft, clean cloth. **DO NOT USE** harsh and/or abrasive cleaners.

To help restore the finish, occasionally apply a non-abrasive wax to your showerhead body (follow manufacturers' instructions).

On **CHROME PLATED SHOWER HEADS**, a two (2) part white vinegar, one (1) part water solution can be used to break down excessive mineral deposits on the sprays. Let the showerhead soak in the solution for about ½ hour then rinse thoroughly. Brush off any remaining mineral deposits if necessary.

DO NOT USE the vinegar/water treatment on any finish other than Chrome.

WARRANTY



Additional warranty information can be found at:
www.speakman.com

1

Apply Teflon Tape to the outlet side of shower arm in a clockwise direction.

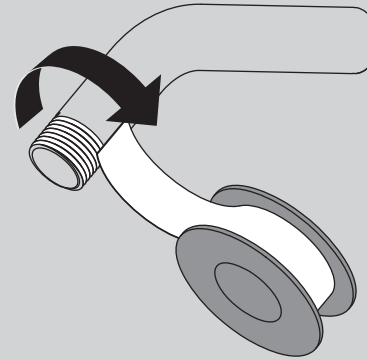

2

Thread Shower head onto shower arm by turning it in a clockwise direction. Tighten with adjustable wrench. Turn water supply on and check for leaks.

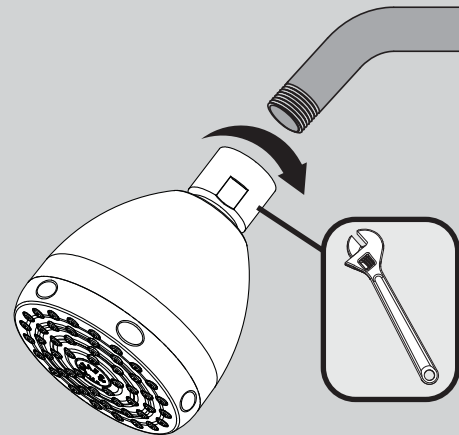

ROUGH IN DIMENSIONS

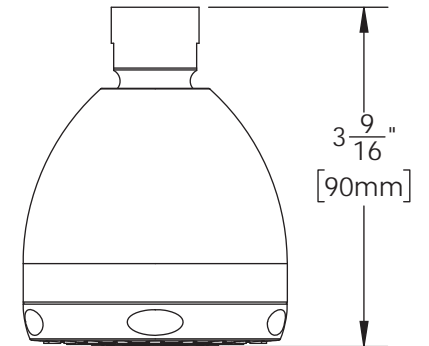
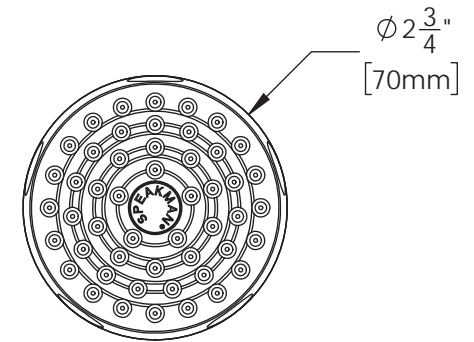

Model: S-2272-E2

Max. Flow Rate: 2.0 gpm (7.6 L/min)

Min. Flow Rate: 1.5 gpm (5.7 L/min) @ 45psi

FOR USE WITH AUTOMATIC COMPENSATING VALVES RATED AT 6.6 L/MIN (1.75 GPM) OR LESS.

Model: S-2272-E15

Max. Flow Rate: 1.5 gpm (5.7 L/min)

Min. Flow Rate: 1.1 gpm (4.2 L/min) @ 45psi

FOR USE WITH AUTOMATIC COMPENSATING VALVES RATED AT 5.2 L/MIN (1.37 GPM) OR LESS.

Specifications:

Inlet: 1/2" NPSM FEMALE

SPEAKMAN COMPANY

S-1554 Installation, Maintenance & Operation Instructions

TUB SPOUT

DESCRIPTION

Speakman polished chrome plated metal tub spout.

SPECIFICATIONS

1/2" NPT FEMALE INLET

SHIPPING WEIGHT: XXX LBS.

INSTALLATION

Apply teflon tape or pipe dope to male threads and thread spout onto piping. Wrench tighten carefully. Check all connections for leaks.

MAINTENANCE

The gleaming finish of your SPEAKMAN tub spout can be cleaned by using mild soap and warm water. Dry immediately with a soft, clean cloth for best results.

ROUGH-IN MEASUREMENTS

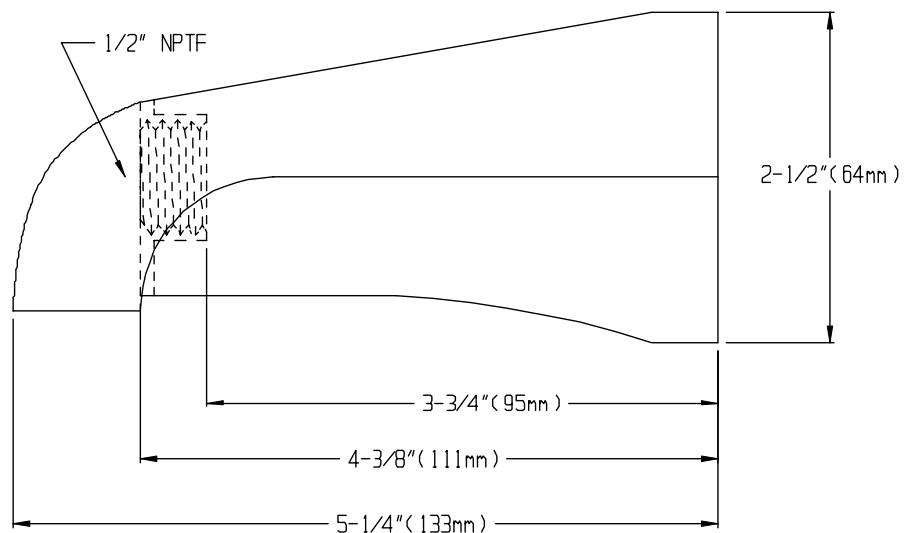

Product improvements may cause specification and dimensional changes without notice.

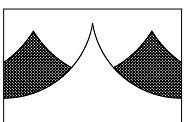

SPEAKMAN COMPANY
The Quality Leader Since 1869
P.O. Box 191, Wilmington, DE 19899-0191 USA
1-800-537-2107, Fax: 1-800-977-2747

04/00
92-1819