

# SPEAKMAN® SE-573

## Laboratory Back Deck Mounted Eye/Face Wash

### FEATURES:

- Back deck sink mounted
- (2) yellow/black, plastic, soft sprays with flip-top dust caps
- Brass, chrome-plated valve
- Swing activated
- ½ in. NPT male inlet
- 3.9 gpm @ 30 psi
- Universal emergency sign included

### FINISHES:



Chrome

### COMPLIANCE:

- ANSI/ISEA Z358.1 certified

### OPTIONS:

Add suffix to model #

- In-line strainer for ½ in. IPS piping  ILS

### WARRANTY:

- 3 year limited



### DIMENSIONS:

NOTE: 1. All dimensions are in inches (millimeters) unless otherwise specified and are subject to change without notice.

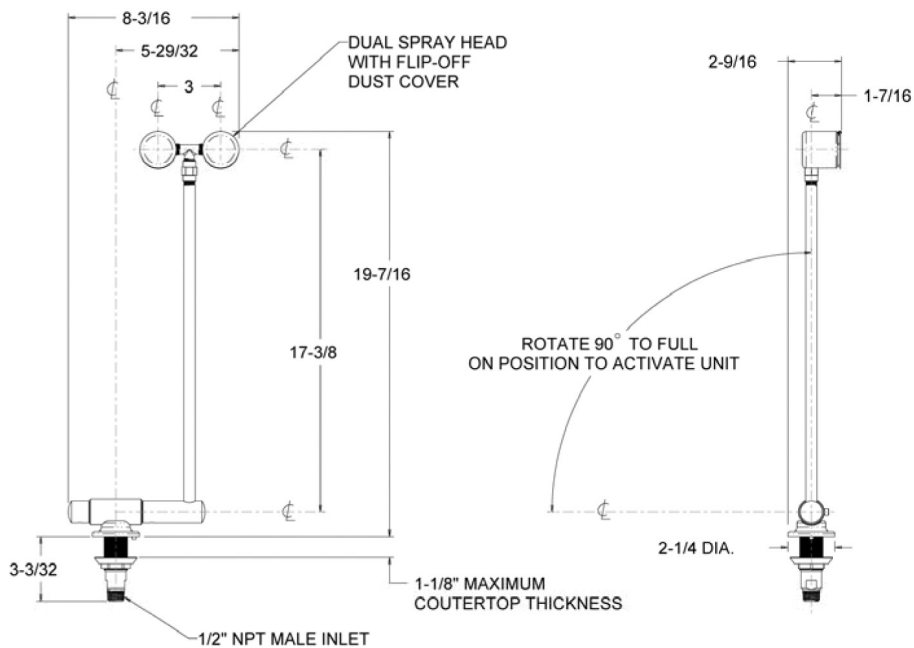

FIGURE #2

Architect/Engineer Approval Space:

SPEAKMAN  
400 ANCHOR MILL ROAD  
NEW CASTLE, DE 19720

P: 800-537-2107  
F: 800-977-2747  
W: WWW.SPEAKMAN.COM  
R: FEBRUARY 2018