

**SPEAKMAN COMPANY**  
**S-8710 Installation, Maintenance & Operation Instructions**  
**SENSORFLO® BATTERY POWERED LOW SPOUT LAVATORY FAUCET**

**DESCRIPTION**

Speakman SENSORFLO faucet. Battery powered low spout lavatory sensor faucet with 4" deck plate. All metal spout assembly consists of polished chrome plated removable cover and black powder coated chassis. Sensor module powered by two (2) 3-volt DC lithium batteries with waterproof connectors housed above counter in faucet body. Low battery warning light. Solenoid with built-in filter. Vandal resistant 60 second time out feature. Water conserving vandal resistant recessed aerator reduces water flow to 2.2 GPM / 8.4 LPM to meet requirements of ANSI A112.18.1M for flow rates. ADA compliant. Note: 3/8" Stainless Steel Hoses are optional.

**SPECIFICATIONS**

INLET SUPPLY: 3/8" COMPRESSION WITH MALE THREADS

FLOW RATE: 2.2 GPM / 8.4 LPM

SHIPPING WEIGHT: 5.0 LBS

**OPTIONS**

BO – Vandal Resistant 0.5 GPM Flow Control

HS – 3 Stainless Steel Flexible Hoses for use with Tee or Mixer

HTS – 1 Stainless Steel Flexible Hose

GB – Vandal Resistant 1.5 GPM Aerator Outlet Device

LF – Vandal Resistant Laminar 2.2 GPM Flow Control

T – Tee with check valves

TMV – Under-Counter Thermostatic Mixing Valve with check valves

VRS - Vandal Resistant Screws with Wrench

**INSTALLATION**

Remove cover from faucet body. Disconnect sensor module wires and remove module from faucet. Remove battery cover from module and install new batteries, taking care to ensure correct polarity. Reassemble in reverse order as above. Make sure module wire is plugged in and clipped into place on top of the module. Wires should be on the inside of cover screw bosses of chassis to prevent pinching. Reattach cover to faucet with screws and wrench provided. Install vandal resistant aerator with wrench provided. Ensure gasket is properly seated on bottom of faucet chassis. Insert faucet shank and wire through hole on the center of deck plate. With notch on deck plate center hole facing forward, fasten faucet to deck plate using four (4) screws provided. Tighten two anti-spin mounting nuts to bottom of deck plate and slip rubber gasket onto bottom of deck plate. Carefully feed wire from faucet through deck hole, mounting faucet on fixture. Attach notched wire guard (notched end up) washer and lock nut onto faucet shank and secure faucet to fixture. CAUTION: Sensor module wire must be inside channel of rubber wire guard to keep wire from being pinched or cut when tightening washer and lock nut. Further secure faucet to fixture with the two (2) cup washers and wing nuts (cup washers should face up). Attach outlet of solenoid valve to shank of faucet. Attach supply to solenoid valve using 3/8" compression fittings. DRY CONNECTIONS ONLY. Connect wire from faucet to solenoid valve. With drain installed, turn on water and activate the faucet, checking for proper operation and all connections for leaks.

**OPERATION**

Speakman SENSORFLO faucets are thoughtfully designed for all in mind. Require no handles to turn, lift or push, water flows only when hands are in the lavatory basin. Built in vandal resistant circuitry shuts off the water after continuous flow of approximately 60 seconds. This feature prevents flooding; water is easily turned on again by placing one's hands under the lavatory spout.

**MAINTENANCE (CARE & CLEANING)**

Your SENSORFLO faucet is designed and engineered in accordance with the highest quality and performance standards. With proper care it will provide years of trouble free service. Periodically the faucet will require some minor maintenance to keep it performing at peak performance. The sensor module has a built-in low battery indicator light located in the center of the rectangle infrared lens. This red light will come on when the faucet has approximately 30,000 on/off cycles remaining or 10% of battery life. To replace the batteries follow the first portion of the installation instructions above. Periodically check the

solenoid filter for debris. If debris is present clean the filter toughly. The polished chrome finish of your faucet should be cleaned using mild soap and warm water. Dry immediately with a soft, clean cloth for best results.

S-8710 SERIES

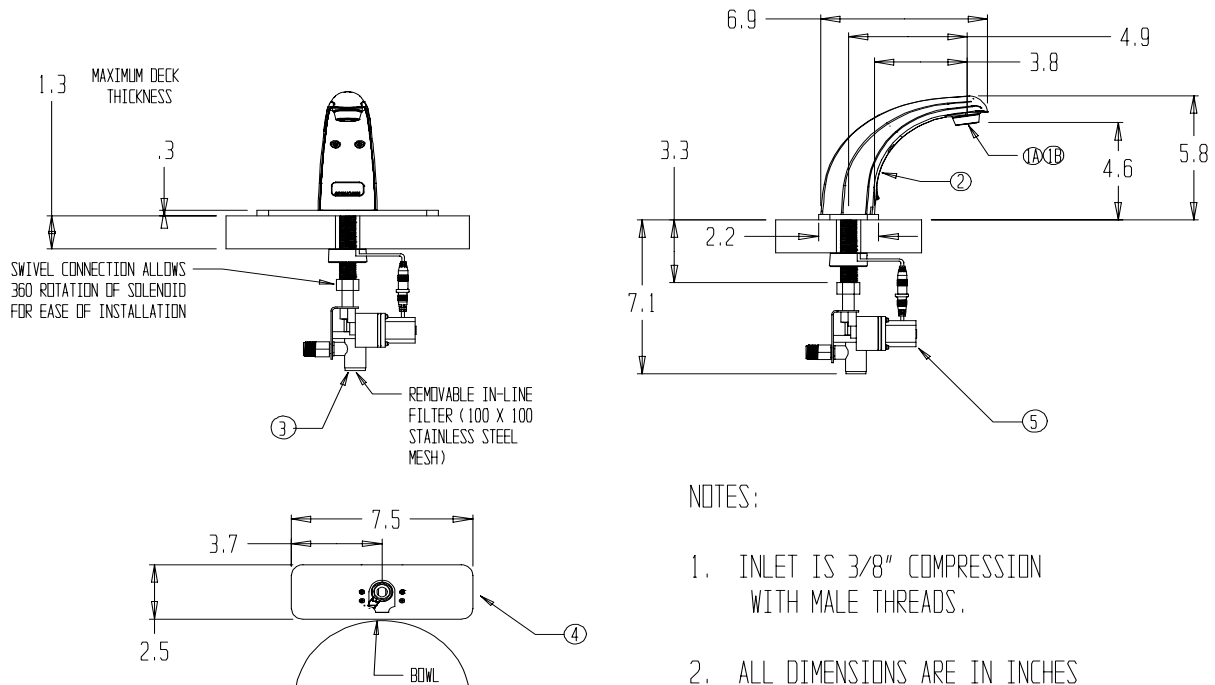

NOTES:

1. INLET IS 3/8" COMPRESSION WITH MALE THREADS.
2. ALL DIMENSIONS ARE IN INCHES UNLESS OTHERWISE SPECIFIED AND ARE SUBJECT TO CHANGES WITHOUT NOTICE.

NOTE:\*

POSITION FAUCET AS CLOSE TO THE EDGE OF THE SINK AS POSSIBLE. ENSURE ADEQUATE CLEARANCE FOR WIRE PROTECTOR, WIRES, WASHERS, AND NUT.

| ITEM NUMBER | REPAIR / REPLACEMENT PARTS<br>PART OR GROUP NUMBER | DESCRIPTION                           |
|-------------|--|---------------------------------------|
| 1A          | RPG05-0674-PC                                      | 2.2 GPM AERATOR                       |
| 1B          | RPG38-0128-PC                                      | 0.5 GPM FLOW CONTROL                  |
| 2           | RPG10-0068-PC                                      | COVER WITH SCREWS                     |
| 3           | RPG66-0044   | SOLENOID FILTER SCREEN                |
| 4           | RPG66-0106-PC                                      | 4" DECK PLATE WITH MOUNTING HARDWARE  |
| 5           | RPG76-0033   | SOLENOID VALVE ASSEMBLY               |
| NOT SHOWN   | RPG76-0041   | 3 VOLT LITHIUM BATTERIES (2)          |
| NOT SHOWN   | RPG76-0039   | SOLENOID DIAPHRAM & O-RING REPAIR KIT |
| NOT SHOWN   | RPG66-0142   | LAVATORY SENSOR MODULE WITH BATTERIES |

**SPEAKMAN®**

PO Box 191 Wilmington, DE 19899

Phone: 800-537-2107 Fax: 800-977-2747

Visit us on the web at [www.speakmancompany.com](http://www.speakmancompany.com)