

## INSTRUCTIONS FOR MODELS

SEF-18100  
SEF-18200  
SEF-18100-8  
SEF-18200-8  
EYESAVER®  
Sensor Faucet

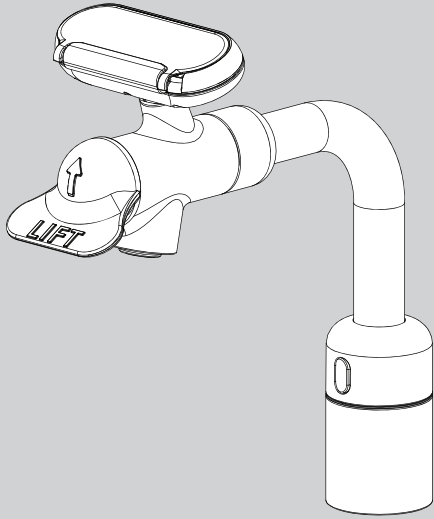

\* YOUR FAUCET MAY DIFFER IN APPEARANCE TO ITEM SHOWN, IT WILL INSTALL WITH IN THE SAME MANNER.

### NEED HELP?

For additional assistance or service please contact:

**SPEAKMAN®**

800-537-2107

customerservice@speakman.com

www.speakman.com

92-SEF-18100-01

## TOOLS AND SUPPLIES



### IMPORTANT

- The supply line for the eyewash shall provide an uninterrupted supply of flushing fluid at a minimum of 30 psi flowing pressure. If shut off valves are installed in the supply line of the eyewash, provisions shall be made to prevent unauthorized shut off. ANSI Z358.1 requires that all emergency equipment shall be tested weekly to verify proper operation and inspected annually to assure conformance with ANSI Z358.1 requirements.

- Do not over-tighten any connections or damage may occur.

- Be sure to read instructions thoroughly before beginning installation.

- This faucet has an operating range of 20-80 psi.

- This installation manual covers several models. While the appearance of your faucet may vary, the installation steps required are the same as shown in this manual.

### SAFETY TIPS

Cover your drain to prevent loss of parts. Be sure to wear eye protection while cutting pipe.

### WARRANTY

Warranty information can be found at: [www.speakman.com](http://www.speakman.com)

**1** Ensure water supplies are shut OFF. Remove existing faucet spout and clean mounting surface. Verify that the Rubber Gasket (1) is in position and aligned to the base of the Faucet Spout. Place Hoses and Sensor Wires carefully, one at a time, through hole in mounting surface. Lower Faucet Spout into position.

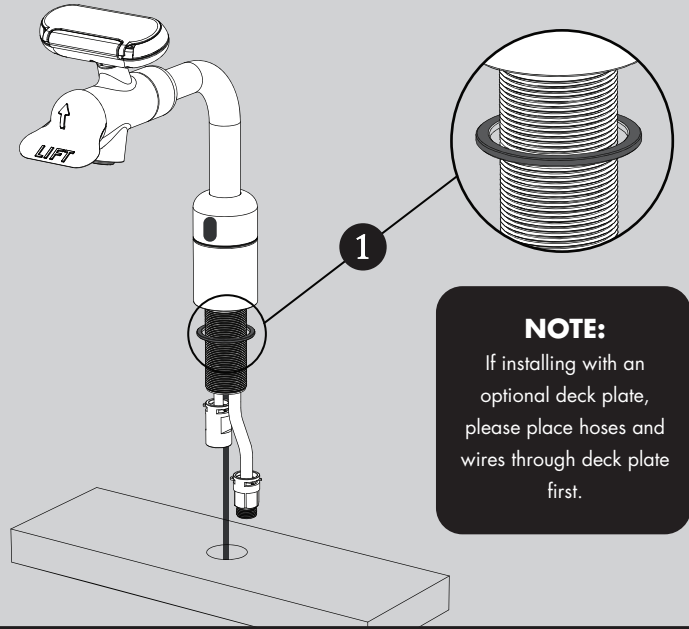

**NOTE:**  
If installing with an optional deck plate, please place hoses and wires through deck plate first.

**2** From below, install Rubber Mounting Washer (1), Metal Mounting Washer (2), and Mounting Nut (3).

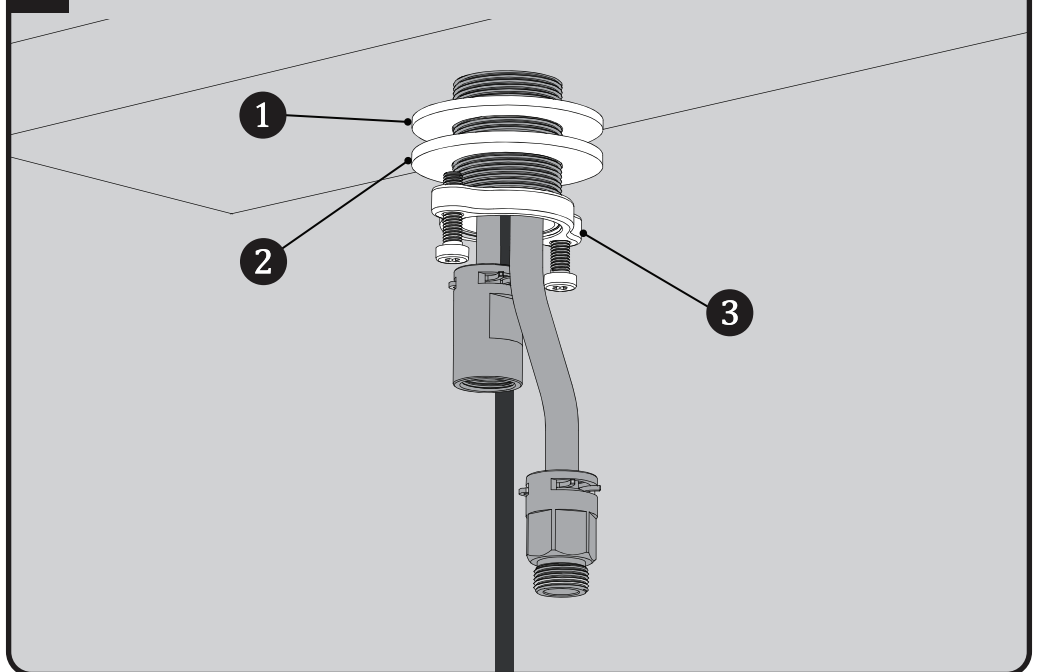

**3** This Faucet has a integral swivel feature. Verify sweep of Faucet Spout and align properly before securing Faucet Spout into final position.

**NOTE:** The SPEAKMAN logo at the base of the faucet should be facing front when installed properly.

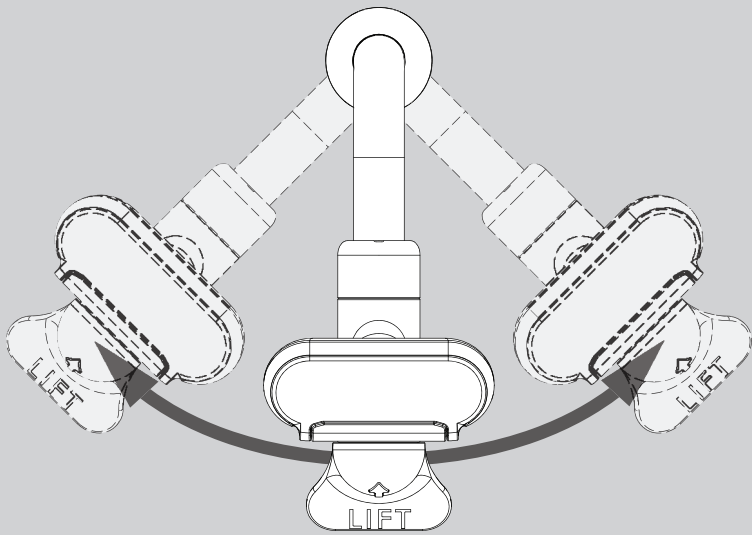

**4** Align Mounting Nut (1) so the Mounting Nut Screws (2) are aligned towards the front and rear of faucet as shown below. Final tighten Mounting Nut Screws (2) using a Phillips Screwdriver.

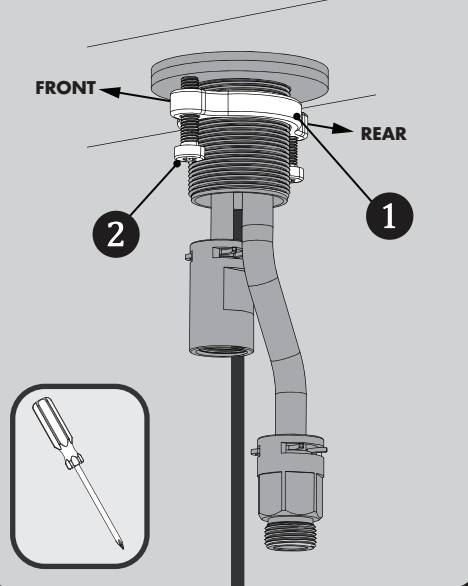

**5** Install one end of the Included Flex Hose (1) to the Female Inlet (2) of the faucet. Install the remaining end of the Included Flex Hose to the OUTLET of the Solenoid (3). Wrench tighten.

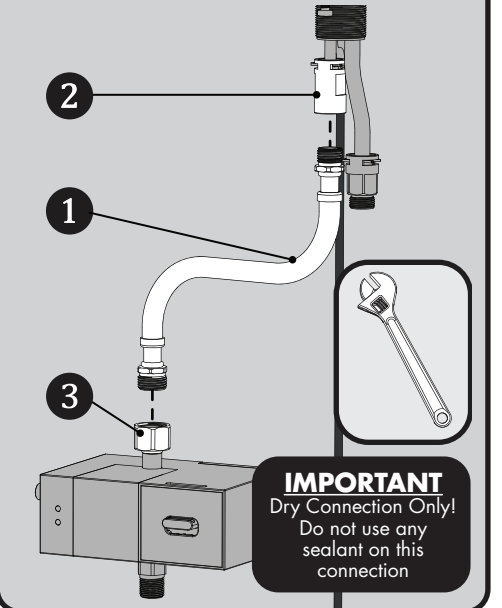

**6** Place the Solenoid Assembly against the desired mounting surface while ensuring adequate clearance for servicing of all connections. If using the optional A/C Adapter, consider the distance to the nearest electrical outlet. Solenoid Assembly should be mounted so the inlet and outlet ports are aligned vertically. Mark location of Solenoid Assembly on the mounting surface using a pencil.

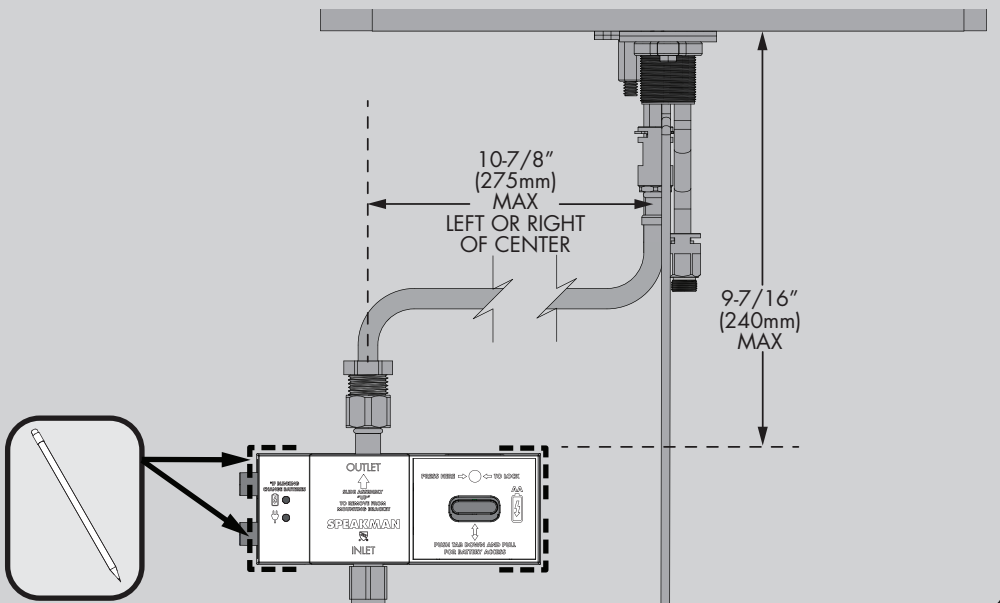

**7** Remove Mounting Bracket (1) from Solenoid Assembly. Using the previously marked location on mounting surface, align Mounting Bracket (1) horizontally to approximate position and mark the mounting locations with a pencil. If mounting on drywall and not to stud, use the appropriate anchors and fasteners for application. Recommend screw in easy anchor or equal for drywall.

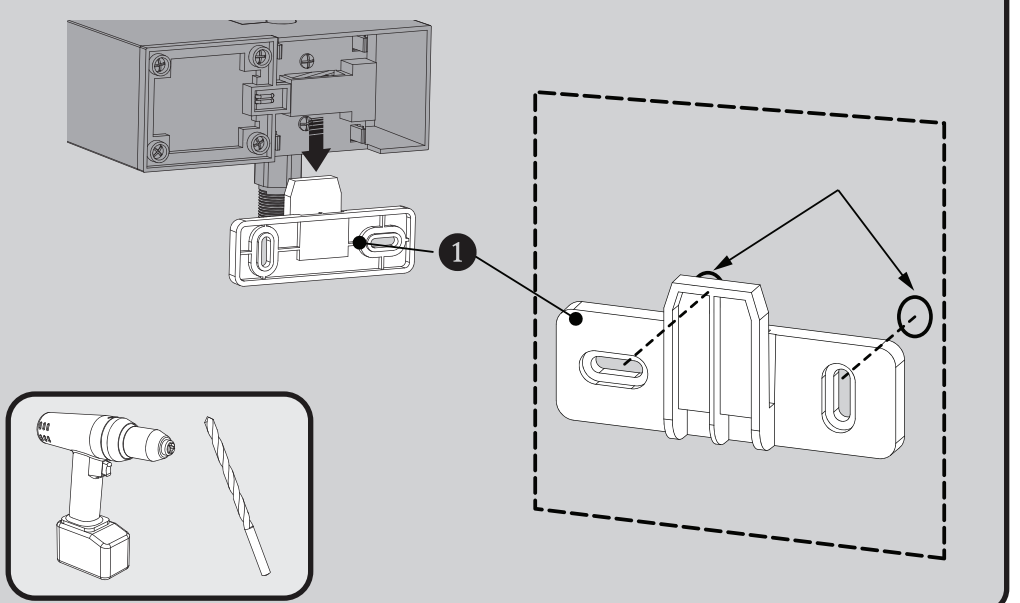

**8** After securing the Bracket to the mounting surface, align and slide Solenoid Assembly over Mounting Bracket.

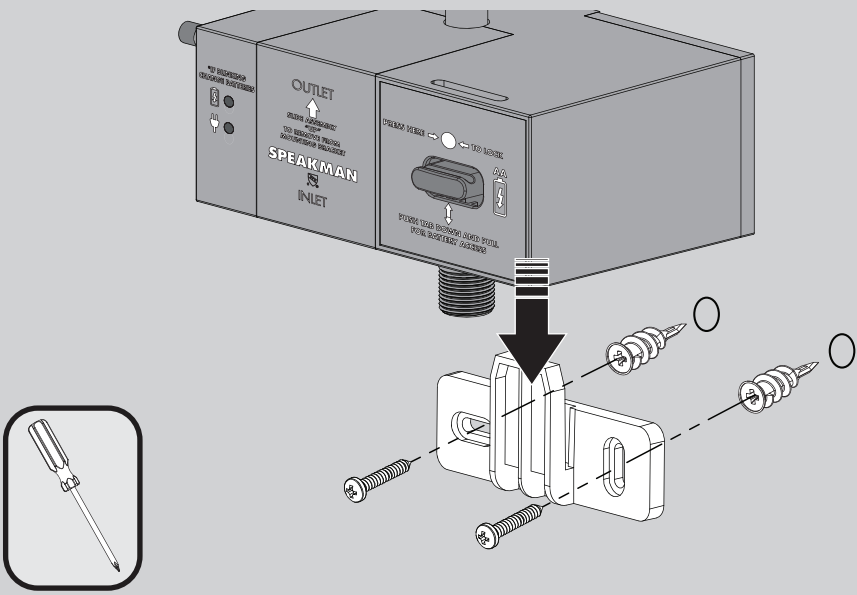

**9** Make electrical connections from the Sensor Eye to the Solenoid Assembly. Connect the Blue Male Ended Wire to the Blue Female Connection. Connect the Green Male Ended Wire to the Green Female Connection. To further aid proper alignment, there are white alignment lines on the connector ends. These alignment lines should face forward when properly installed.

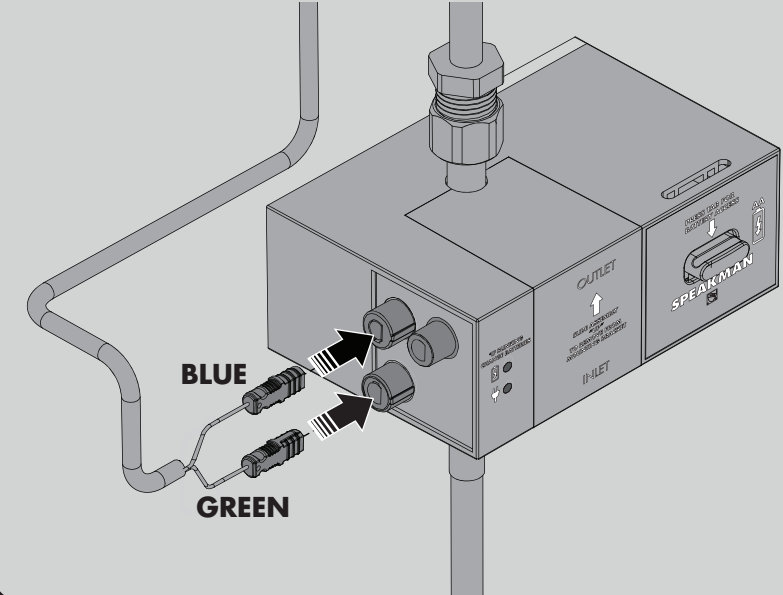

**10 FOR BATTERY MODELS (SEF-18100 SERIES)**

Access the interior Battery Enclosure by pressing down on the tab to release the tray holding the batteries (1). Pull out Battery Tray (2). Insert or replace the batteries with six (6) new standard 1.5v AA batteries. Ensure the position of the new batteries are aligned to the plus (+) and minus (-) symbols within the battery holder.

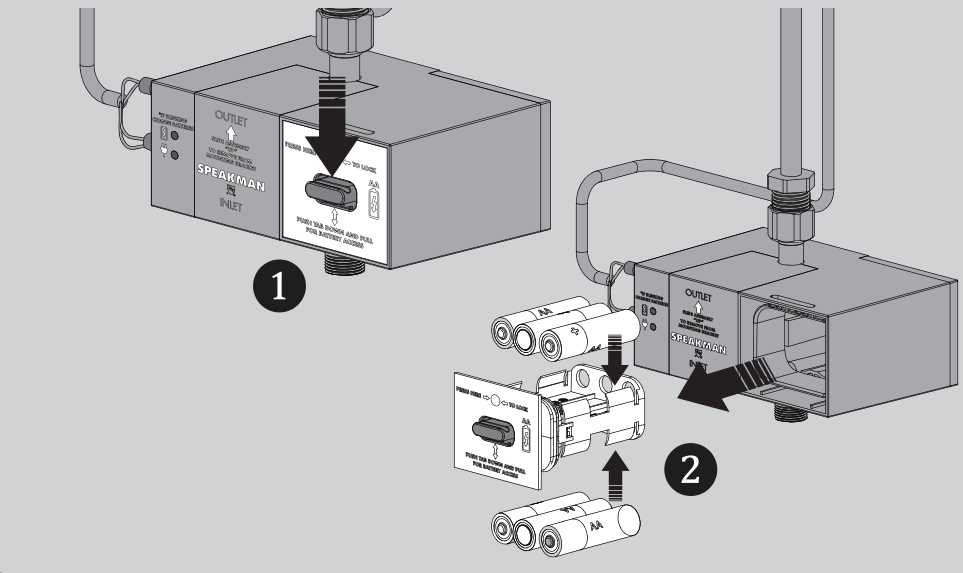

**11 FOR A/C MODELS (SEF-18200 SERIES)**

Verify that no batteries are present within the battery enclosure (1). Connect the A/C Adapter to the BLACK connector on the Solenoid Body (2). Plug the A/C Adapter into the wall outlet. The A/C light (3) should illuminate.

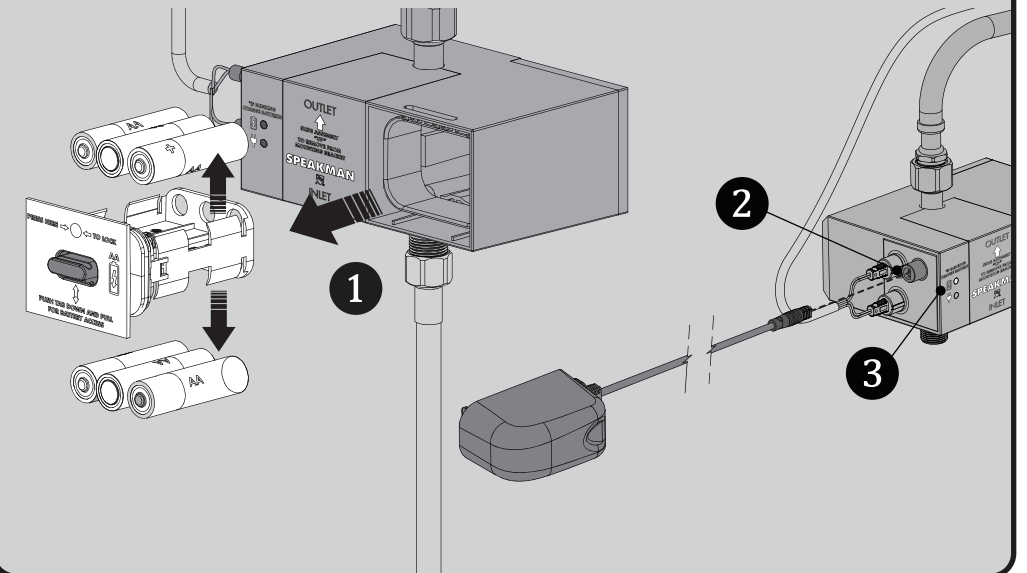

**12** Reinstall the Battery Tray (1). Make sure to press the indicated location until the battery door is fully seated and locks into position (2).

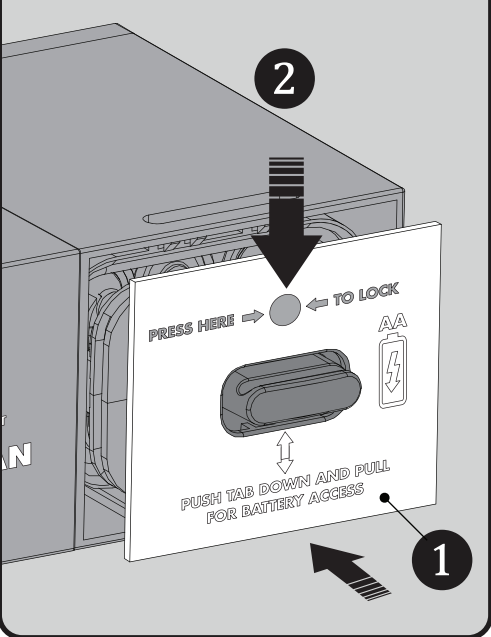

**13** Make **TEPID WATER** connection to the inlet of the Eyewash supply. A Speakman **STW Series** Thermostatic Mixing Valve is recommended (not included). Make **WATER** connection to the inlet of the Solenoid. A Speakman **A-TMV** Thermostatic Mixing Valve is recommended (not included). Inlet supplies are not included. Wrench tighten connections.

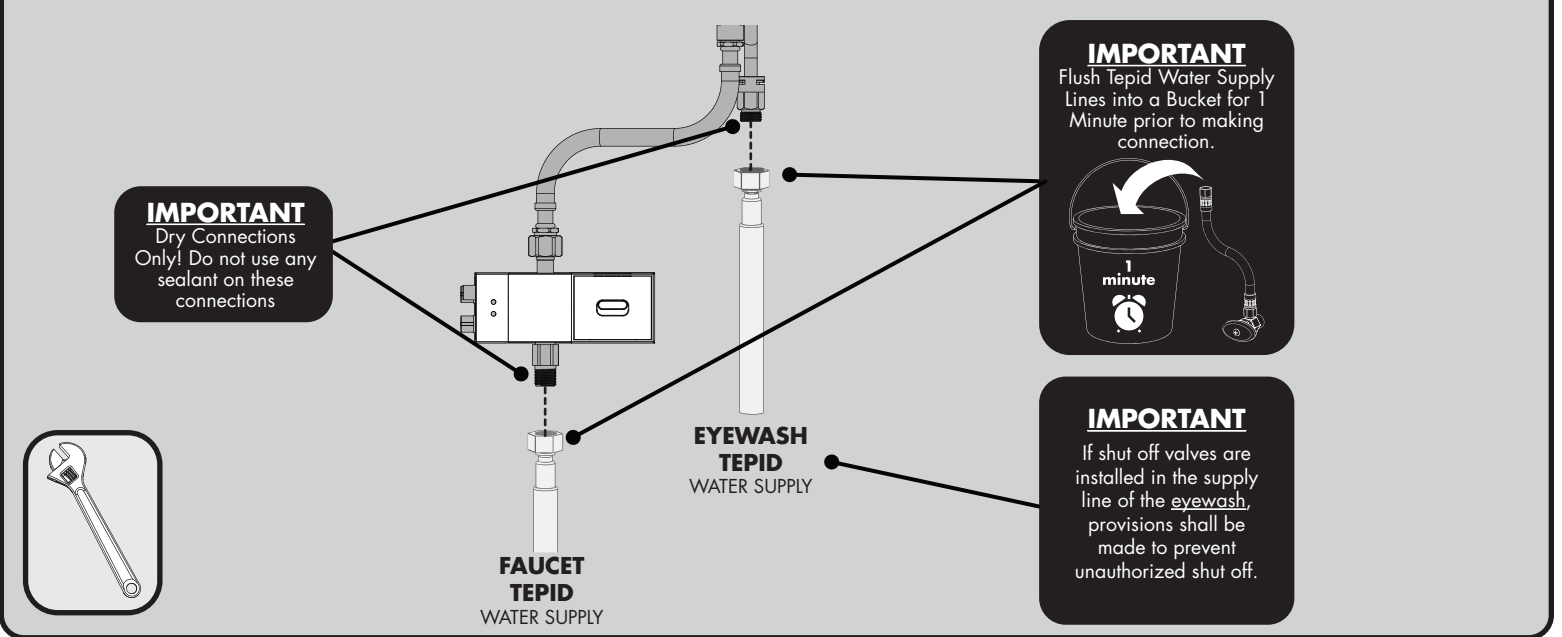

**14** After the assembly is complete, turn the Faucet and Eyewash water supplies on. Activate Sensor and allow Faucet to run for 1 minute to flush out any debris. Check all connections for leaks.

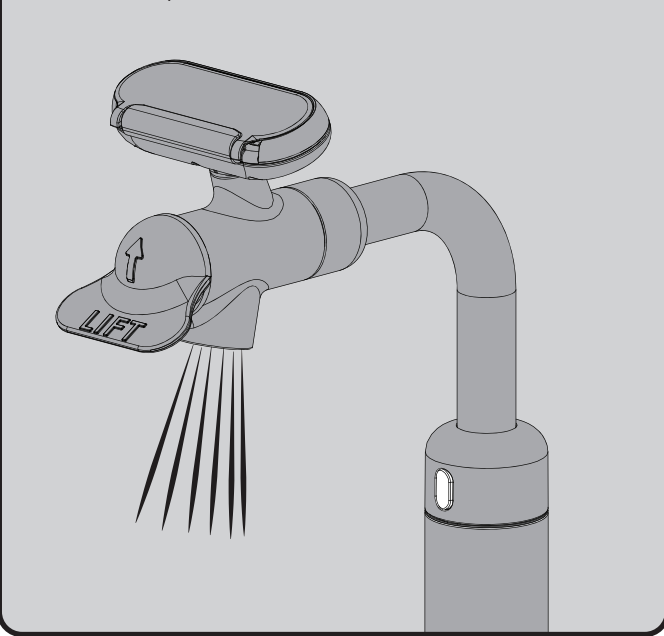

**15** Install Aerator (1) into the Faucet Outlet. Secure with included Aerator Wrench.

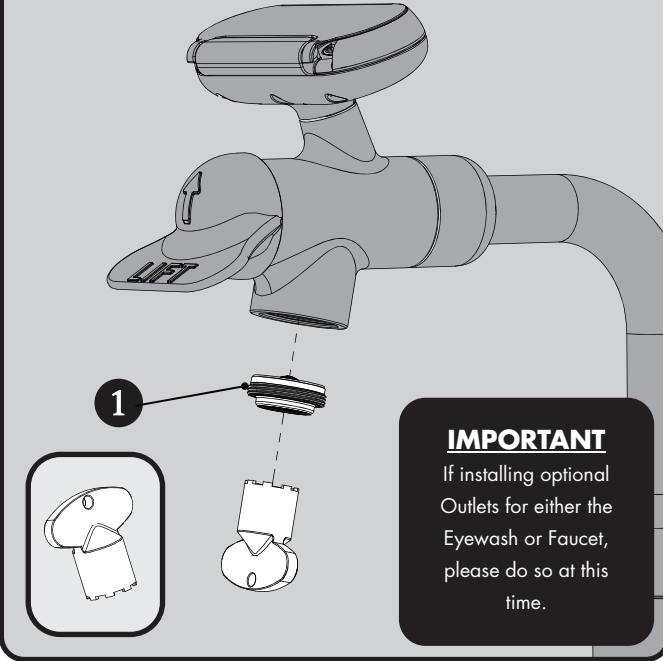

**16** Activate Faucet and test for proper operation. **NOTE: Before testing, you must remove tape from Eyewash Dust Cap.** Lift Eyewash Handle to activate Eyewash and test for proper operation. See "EYEWASH FLOW DATA" chart. Check all connections for leaks.

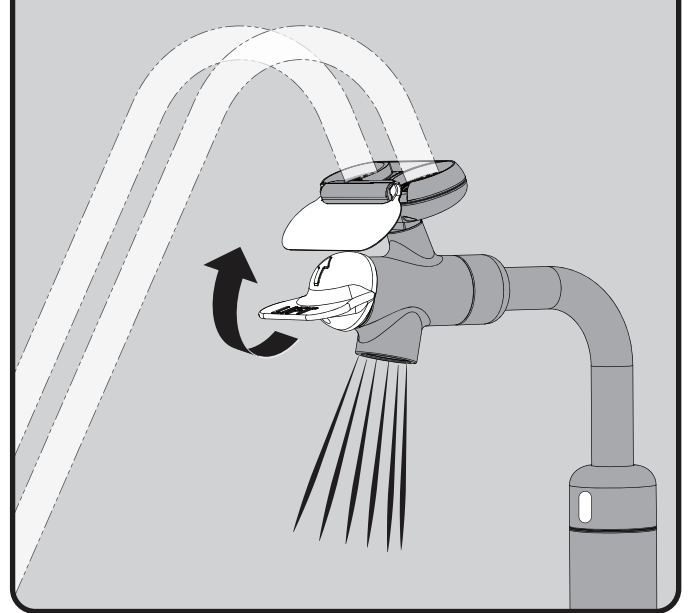

ITEM NO.	PART NO.	DESCRIPTION
1	RPG05-111352	1.2GPM SLIM AIR AERATOR REPAIR GROUP
2	RPG38-110458	SPRAY HEAD REPAIR GROUP
3	RPG76-108060	SOLENOID BOX WITHOUT BATTERIES

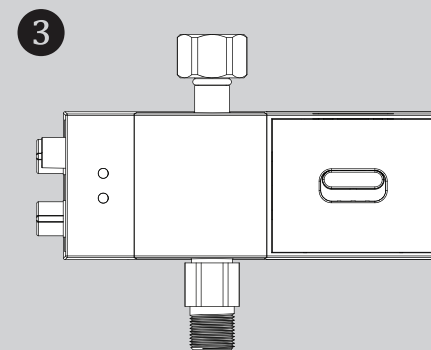
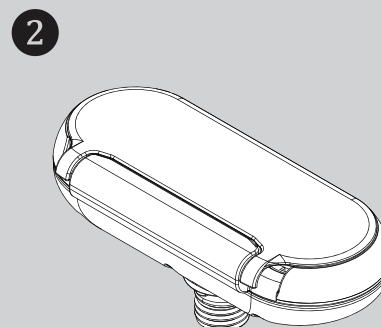
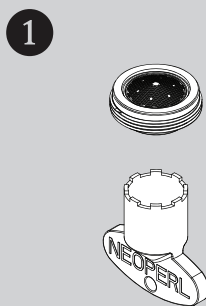

## CARE AND CLEANING

- 1) Your EYESAVER® Faucet is designed and engineered in accordance with the highest quality and performance standards. With proper care, it will provide years of hygienic and trouble-free service.
- 2) Periodically, the Faucet will require some minor maintenance to keep it at peak performance. There are 2 low battery indicator lights. One located on the Sensor on the Faucet body and the other located on the Solenoid Box. When the low battery light on the Sensor blinks, it indicates that the battery is low. However, the Solenoid can still function at this point. When the low battery light on the Solenoid blinks, the Solenoid will stop functioning at this point and the batteries need to be replaced immediately. To replace the batteries, follow the installation instructions in the electrical connections section of this document.
- 3) Periodically clean the In-Line Filter.
- 4) The polished chrome finish of your Faucet should be cleaned using mild soap and warm water.
- 5) Dry immediately with a soft, clean cloth for best results.
- 6) NEVER use abrasive cleaners, chemicals, alcohol or other solvents. They may damage the surfaces of the non-chrome plated finishes.

## TROUBLESHOOTING

### **If water flow from the Faucet decreases:**

- 1) Make sure the supply stops are open.
- 2) Check that the In-line Filter located in the hose connecting the solenoid and the mixer is not blocked with debris. Remove filter from the Solenoid Inlet and rinse filter screen with clean water. Reassemble the filter, open stops, and check water flow. Stops must be turned off when filter is removed.
- 3) Remove the Aerator from the spout using the outlet wrench. Operate the Faucet with outlet device removed. If water flow is acceptable, disassemble the outlet device and rinse components with clean water.

### **If no water flows from the Faucet, and**

*If you can hear a clicking sound of Solenoid opening, but no water flows:*

- 1) Verify that the HOT and COLD wall stops are completely open.
- 2) If the Battery Light within the Sensor Eye or Solenoid blinks continuously, even when the Faucet is not in use, the batteries within the Solenoid have low voltage and need replacement.
- 3) Verify that the In-Line Filter in the Solenoid is not blocked by debris. Clean filter if needed.

*If you do not hear a clicking sound of Solenoid opening and no water flows:*

- 1) If the Battery Light within the Sensor Eye blinks continuously, even when the Faucet is not in use, the batteries within the Solenoid have low voltage and need replacement.
- 2) Unplug connections to Solenoid for 2 minutes. Plug connections back in. The red light on the Sensor should turn on for several seconds before becoming operational. If not, check power supplies and connections.
- 3) Disconnect the existing Solenoid Assembly and connect a new Solenoid Assembly. Activate the Sensor and check for water flow. If the water flows, the existing Solenoid Assembly should be replaced.

*If the batteries have been replaced, but the Faucet still does not operate:*

- 1) Check the battery polarity and electrical connections. Make sure all electrical connections are fully inserted.
- 2) If the Faucet does not operate, replace the existing Solenoid Assembly with one you know to be functioning.

### **If the Faucet activates, but the water will not shut off:**

- 1) Hold a hand in front of the Sensor at up to 7" away for more than 1 minute until the water flow stops. Once the water stops, remove your hand and wait 15 seconds. Then place your hand in front of the Sensor and verify that it is operating properly.
- 2) If the Faucet still does not shut off, cover the front of the sink with a towel. This will eliminate the potential of reflections activating the Sensor.
- 3) If it is a new installation and still not working, replace the Solenoid Assembly.

## QUESTIONS & ANSWERS

### **Q. How does the Sensor Faucet work?**

**A.** It uses laser technology. The Sensor emits a non-visible beam of light. When an object enters the detection area, the Sensor signals the Solenoid Valve to open for water to flow. When an object leaves the detection area, the Sensor signals the valve to close.

### **Q. Is the Sensor Faucet sensor beam adjustable?**

**A.** No, the Sensor Faucet sensor beam is not adjustable. It has been factory set to factory specifications for these Faucets.

### **Q. What about water conservation?**

**A.** The Sensor faucet design directly addresses water conservation. Water savings of up to 85% are not unusual. Additional energy savings are realized by conserving hot water.

### **Q. Can the water temperature of the Sensorflo® Faucet be adjusted?**

**A.** No, If you need to meet ASSE 1070, you must use our TMV (Thermostatic Mixing Valve) option.

### **Q. Does Sensorflo® reduce maintenance?**

**A.** By elimination of on/off handles, control components are reduced and fittings stay cleaner longer. Only a light rinsing and wiping is required to restore the beauty of the Eyesaver® Faucets. Drip stains are eliminated. Fingerprints and soap spots on sinks and fittings are avoided. Finishes last longer and wash areas stay cleaner. Germs and bacteria are not transferred as easily making for a healthier environment.

### **Q. The chrome finish on my Faucet seems to be deteriorating. What can I do to prevent this from happening?**

**A.** Many commercial cleaning products contain harsh chemicals and abrasives. These products should not be used on any chrome-plated plumbing products. Please use only mild soap and water to clean the Faucet. Dry immediately with a soft cloth.

### **Q. Does the Sensor system shut off immediately when an object leaves the sensing area?**

**A.** A very short delay of approximately 0 to 1.5 seconds occurs before water is shut off.

### **Q. Is my Faucet protected from power surges?**

**A.** Yes, this Sensor Faucet has been designed to have built-in power surge protection.

### **Q. If we lose power, do I have to do something to get the Faucet to operate again?**

**A.** After a power outage, the Sensor Faucet is automatically ready for operation as soon as the power comes back on.

### **Q. If I call a plumber to come and install this Faucet, will they know enough to hook it up?**

**A.** Our installation diagrams are very easy to follow.



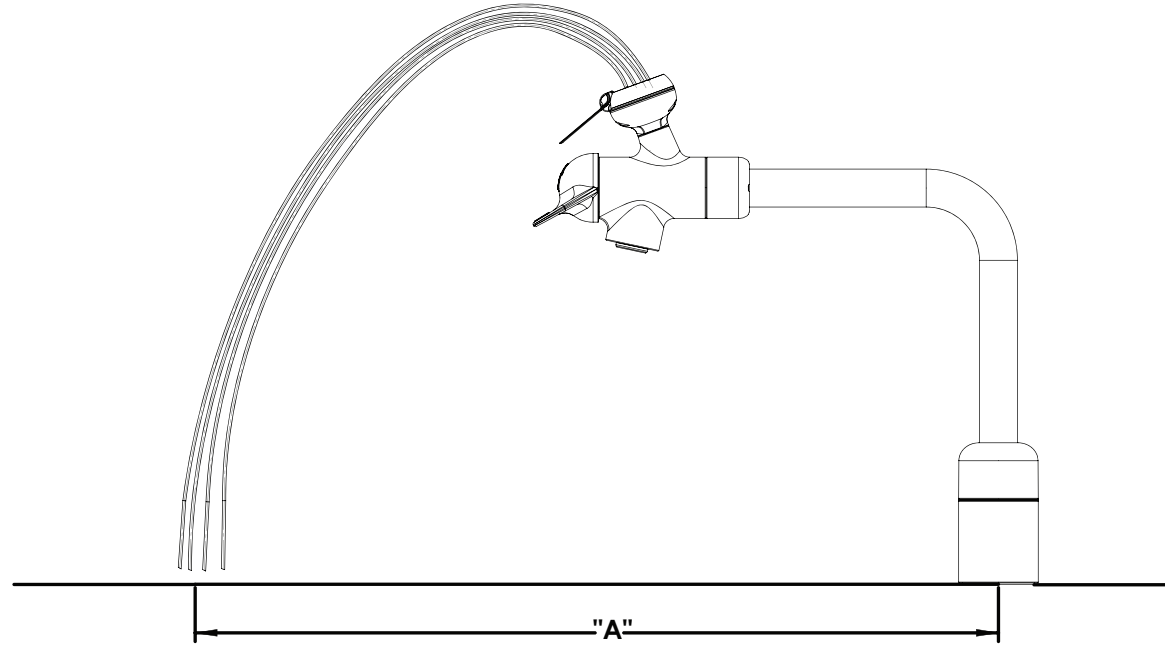

SEF-18100					
FLOWING PRESSURE		FLOW RATE		PLUME DISTANCE "A"	
psi	bar	gpm	L/min	in.	cm
30	2.07	19	7.2	9.5	24.13
40	2.76	2.1	7.9	10.5	26.67
50	3.45	2.2	8.3	10.65	27.31
60	4.14	2.1	7.9	10.5	26.67
70	4.83	2.2	8.3	11	27.94
80	5.52	2.3	8.7	11.5	29.21

SEF-18100-NA					
FLOWING PRESSURE		FLOW RATE		PLUME DISTANCE "A"	
psi	bar	gpm	L/min	in.	cm
30	2.07	19	7.2	9.5	24.13
40	2.76	2.1	7.9	10.5	26.67
50	3.45	2.2	8.3	10.65	27.31
60	4.14	2.1	7.9	10.5	26.67
70	4.83	2.2	8.3	11	27.94
80	5.52	2.3	8.7	11.5	29.21

SEF-18100-8					
FLOWING PRESSURE		FLOW RATE		PLUME DISTANCE "A"	
psi	bar	gpm	L/min	in.	cm
30	2.07	176	6.7	115	29.21
40	2.76	2.03	7.7	13	33.02
50	3.45	2.18	8.3	14	35.56
60	4.14	2.1	7.9	13	33.02
70	4.83	2.1	7.9	13.5	34.29
80	5.52	2.2	8.3	13.75	34.93

SEF-18100-8-NA					
FLOWING PRESSURE		FLOW RATE		PLUME DISTANCE "A"	
psi	bar	gpm	L/min	in.	cm
30	2.07	176	6.7	115	29.21
40	2.76	2.03	7.7	13	33.02
50	3.45	2.18	8.3	14	35.56
60	4.14	2.1	7.9	13	33.02
70	4.83	2.1	7.9	13.5	34.29
34.93	34.93	34.93	34.93	34.93	34.93

**NOTE:** If plume heights are low, check to ensure that your supply valves are fully open. If there is a noticeable height difference between the two plumes, remove the aerators and flow controls and remove any debris that would inhibit the flow of water.

**NOTES:**

**COMPLIANCE:**

- ANSI/ISEA Z358.1 certified
- ASME A112.18.1/CSA B125.1 certified
- IGC 272 certified
- NSF/ANSI 61 certified
- NSF 372 certified

**CONNECTIONS:**

- Faucet Inlet: 3/8" compression
- Eyewash Inlet: 3/8" compression

Contractor to supply necessary inlet connections.

**LAVATORY ROUGH-IN**

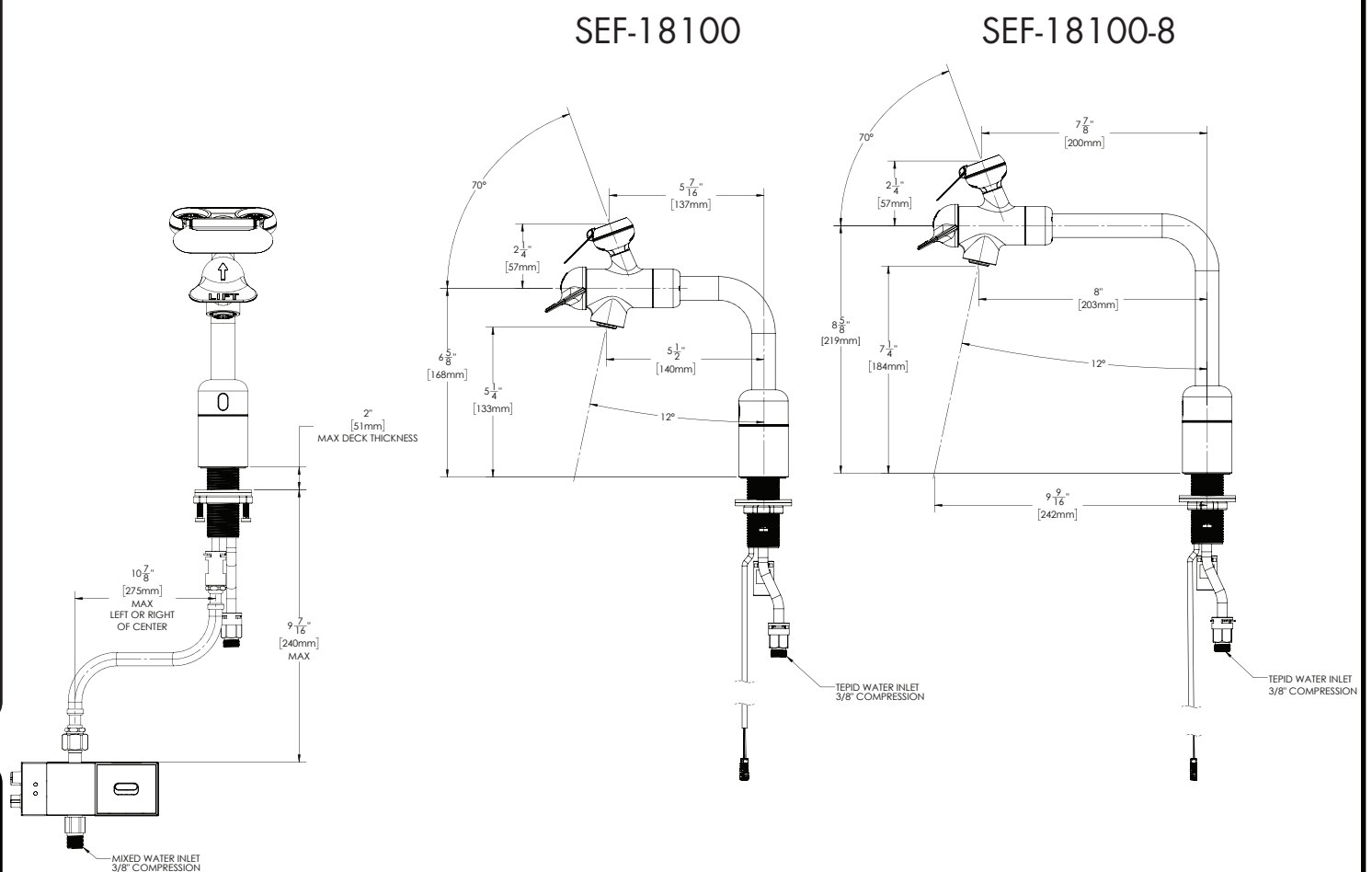
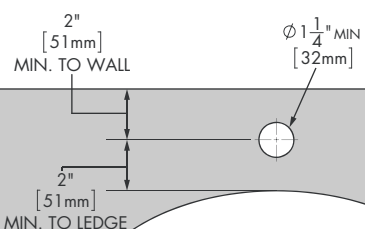

NOTE: UNLESS OTHERWISE SPECIFIED, ALL INLETS ARE 3/8" COMPRESSION WITH MALE THREADS. UNLESS OTHERWISE SPECIFIED, ALL DIMENSIONS ARE IN INCHES AND ARE SUBJECT TO CHANGE WITHOUT NOTICE.

## INSTRUCTIONS FOR MODELS

### A-TMV Thermostatic Mixing Valve

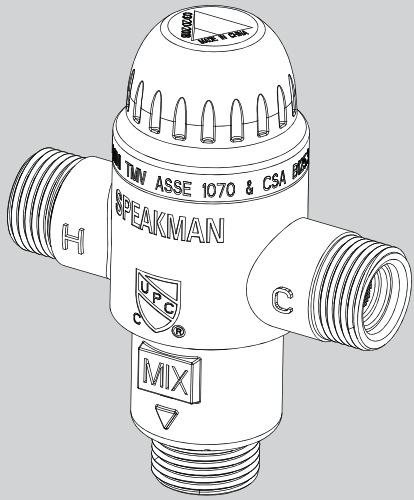

#### NEED HELP?

For additional assistance or service please contact:

**SPEAKMAN®**

800-537-2107

customerservice@speakman.com

www.speakman.com

92-A-TMV-02

## TOOLS AND SUPPLIES

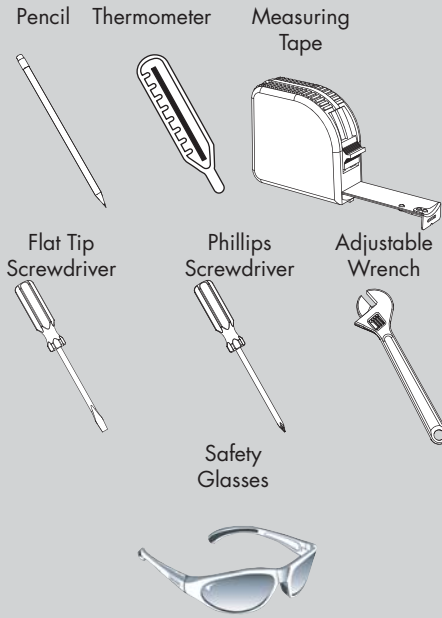

#### HELPFUL TOOLS & SUPPLIES:

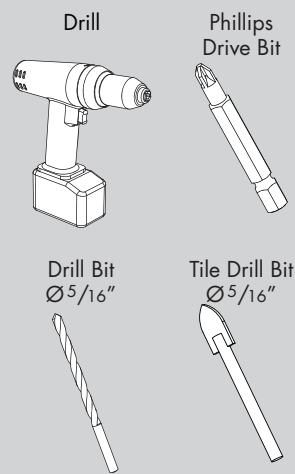

## IMPORTANT

- Compliance and conformity to local codes and ordinances is the responsibility of the installer.
- Valve should be accessible for testing, adjustment and maintenance in the installed position.
- Make sure that all water supply lines have been flushed and then completely turned off before beginning installation. Debris in supply lines can cause valves to malfunction.
- Ensure the mounting structure and mounting hardware can safely support the product in use.
- Do not over-tighten any connections or damage may occur.
- Be sure to read instructions thoroughly before beginning installation.

## IMPORTANT

#### SAFETY TIPS

Be sure to wear eye protection.

#### MAINTENANCE

See section "Testing the Mixing Valve".

#### WARRANTY

Warranty information can be found at:  
www.speakman.com

- 1 Determine desired mounting position of the A-TMV with Plastic Wall Bracket. Ensure mounting location is capable of supporting the product in use. Using a pencil, mark the hole location.

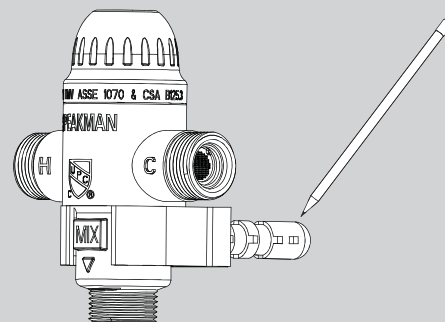

- 2 If mounting to drywall or tile, select appropriate 5/16" drill bit and drill guide hole at marked location. Install the Plastic Wall Bracket into the drilled hole and press/tap into place until the bracket is flush to the wall surface. Secure the Plastic Wall Bracket to the wall with the proper Mounting Screw (included).

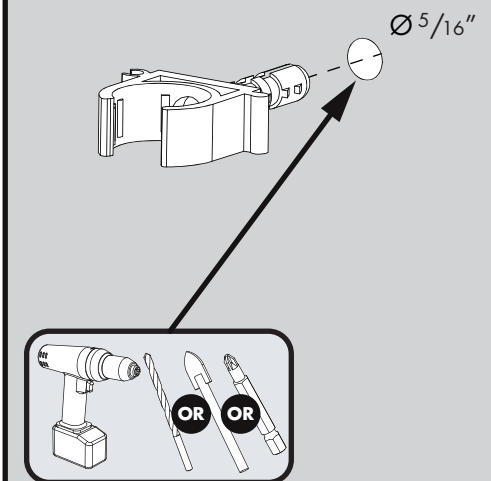

- 3 Ensure the A-TMV is vertical and the body rests on the top face of the Plastic Wall Bracket.

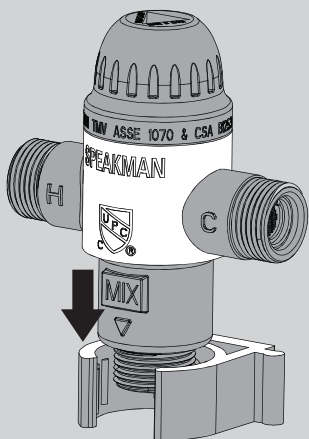

- 4 **Connect Supply Lines and Fixtures.**
  - Ensure incoming water supplies are turned OFF.
  - Install Inlet and Outlet connections to the valve. Wrench Tighten.

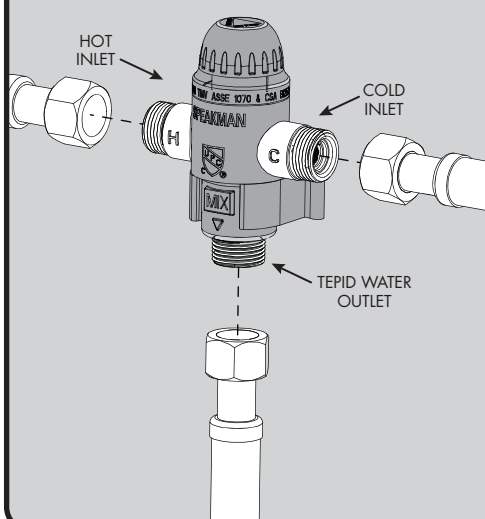

- 5
  - Check for leaks by pressurizing the unit SLOWLY.
  - Check the temperature and adjust if necessary.

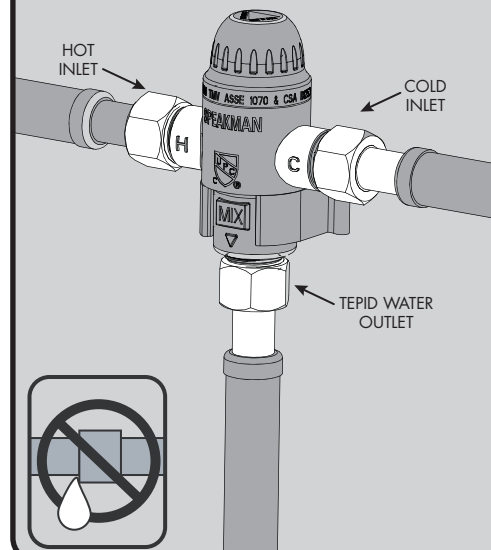

## CAUTION

When maintaining and adjusting the Mixing Valve, all fixtures should be isolated from use. Speakman recommends that appropriate personnel shall work safely at all times.

## 6 SETTING THE MIXING VALVE

REMOVE THE CAP WITH FLAT TIP SCREWDRIVER FROM THE NOTCH ON THE CAP

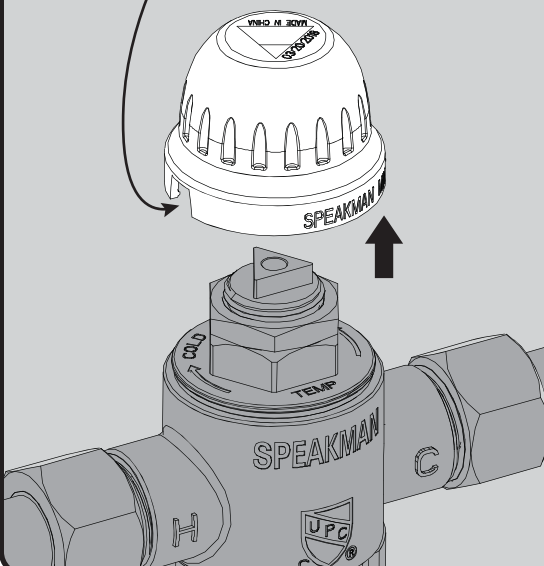

Should the Valve require adjustment, or an application require a different set temperature, proceed as follows:

#### Adjust Temperature with Water Running

- Check the temperature with a stick thermometer.
- Contact proper medical and safety authorities to determine the correct water temperature for the specific application.
- Remove the Plastic Cap (White) from the Valve using a flat tip screwdriver.

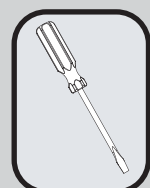

## 7 SETTING THE MIXING VALVE

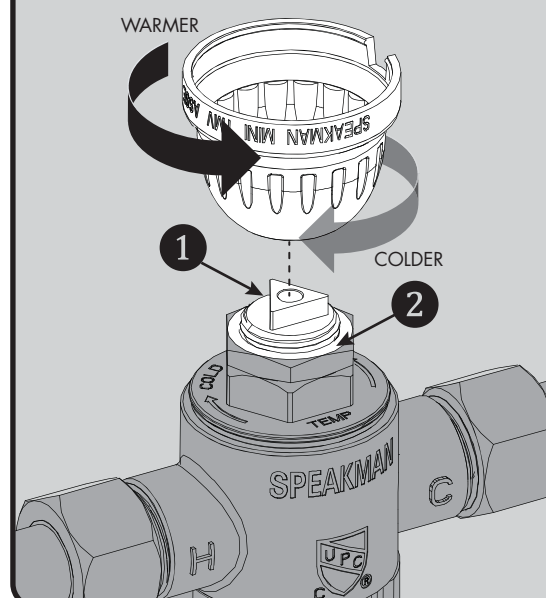

- Create a draw on the Mixing Valve by opening the faucet.
- Loosen, but do not remove the Locking Nut (2) using adjustable wrench. Invert Plastic Cap and align triangular recess in cap to the Adjuster Screw (1).
- Set the outlet temperature by turning the Adjuster Screw clockwise to reduce temperature, counterclockwise to increase temperature. Use a stick Thermometer to check the outlet temperature.
- Tighten the Locking Nut to avoid inadvertent adjustment of outlet temperature.

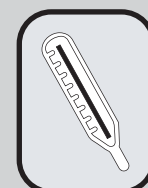

## 8 TESTING THE MIXING VALVE

After installation, test the Mixing Valve and the faucet it serves for proper operation by following the steps below.

Valve temperature test procedure is as follows:

1. Activate faucet to observe and record the temperature with a stick Thermometer. If the temperature of the Thermometer is not correct, readjust the Mixing Valve according to the section "Setting the Mixing Valve".

## 9 REPLACING THE THERMOSTATIC ELEMENT

The Thermostatic Element's replacement procedure is as follows:

1. Shut off the hot water supply and cold water supply to the Mixing Valve.
2. Remove the Plastic Cap and disassemble the Valve Cap.
3. Remove Thermostatic Element in conjunction with the Shuttle from the Valve Body. No special tools are required.
4. Inspect the Thermostatic Element. If it feels slippery to the touch, then the Element has lost its wax and requires replacement. If the Thermostatic Element feels normal to the touch, then it is in good condition and operable.
5. Verify that the stainless steel Piston moves freely up and down within the Element's body.

### Note:

Gallon per minute ratings may vary depending upon incoming water temperatures and pressures. Hot and cold water inlet pressures must be equal.

Provisions shall be made to thermally isolate the valve.

## A-TMV REPAIR PARTS

**SPEAKMAN®**

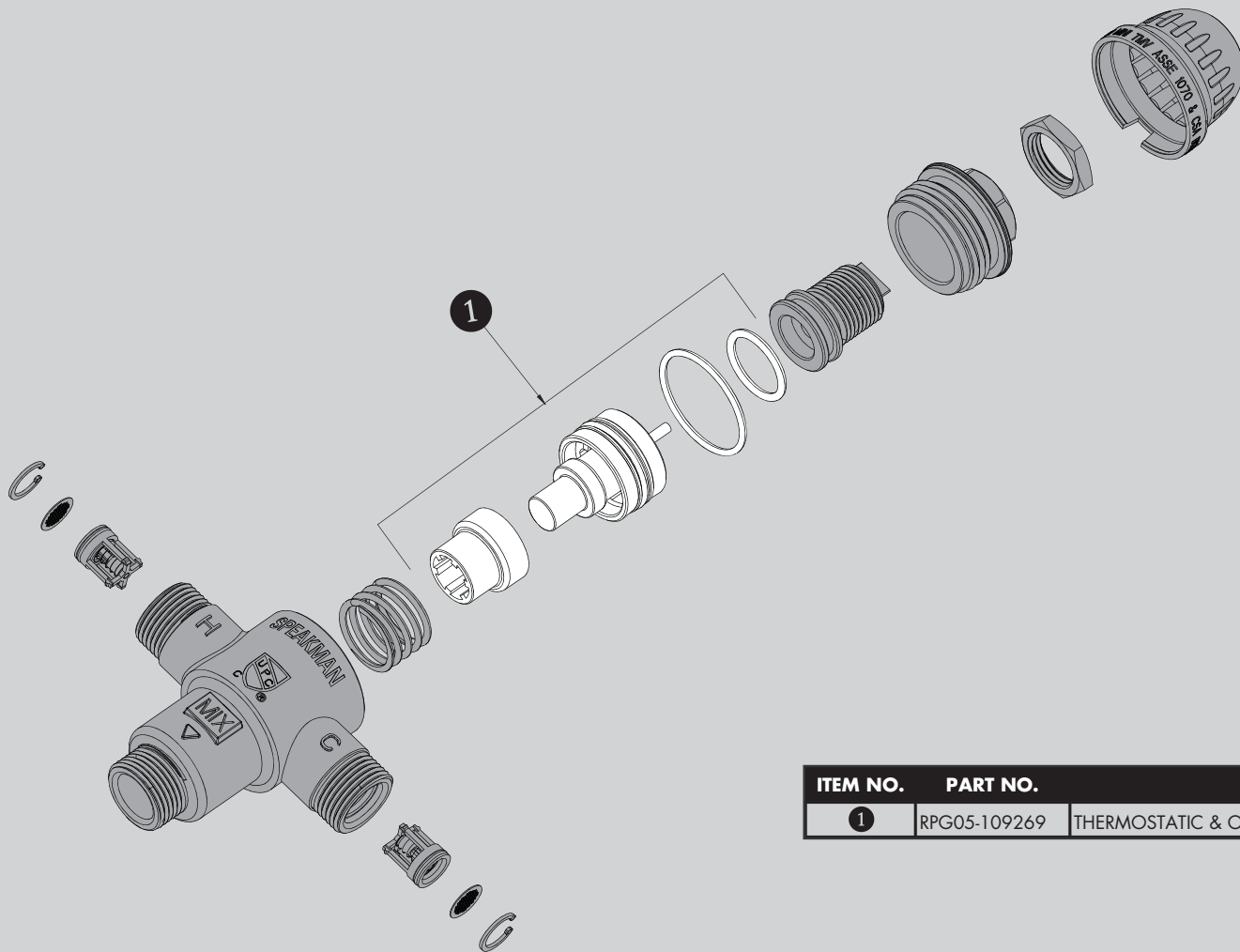

ITEM NO.	PART NO.	DESCRIPTION
1	RPG05-109269	THERMOSTATIC & O-RING REPAIR KIT

## A-TMV ROUGH-IN DIAGRAM

**SPEAKMAN®**

### NOTES:

#### COMPLIANCE:

ASSE 1070 & cUPC Certified

- Inlets: 3/8" Compression Male Threads
- Outlet: 3/8" Compression Male Threads
- Maximum Working Pressure: 125 psi (861.9 kPa)
- Rated flow at 30 psi (206.9 kPa) differential pressure: 2.16 GPM (8.2 L/min)
- Minimum flow rate: 0.35 GPM (1.3 L/min)
- Hot Water Inlet Temperature Range: 120° – 180° F
- Cold Water Inlet Temperature Range: 37° – 80° F
- Outlet Water Temperature Range: 80° – 120° F
- Minimum Temperature Differential (Hot to Mix): 18° F (10° C)

Contractor to supply necessary inlet connections.

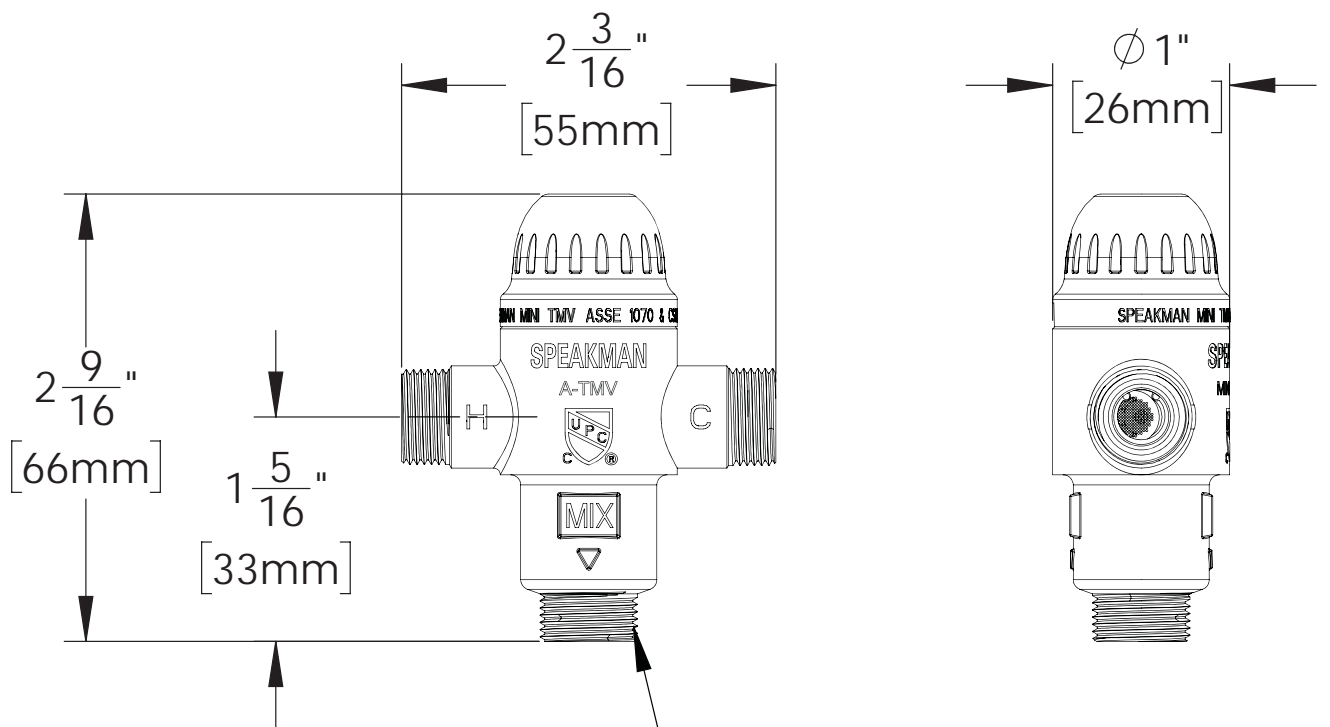

9/16"-24 THREAD FOR  
3/8" COMPRESSION FITTINGS  
(3 PLACES)

### FLOW CAPACITY OF A-TMV

PRESSURE DROP,	psi (bar)	5 (0.4)	10 (0.7)	15 (1.0)	20 (1.4)	30 (2.1)	40 (2.8)	45 (3.1)	50 (3.4)
TEMPERED FLOW,	GPM (L/min)	0.66 (2.5)	1.2 (4.5)	1.5 (5.7)	1.74 (6.6)	2.16 (8.2)	2.51 (9.5)	2.66 (10.1)	2.8 (10.6)

### NOTES:

1. ALL DIMENSIONS ARE IN INCHES [MILLIMETERS] UNLESS OTHERWISE SPECIFIED AND ARE SUBJECT TO CHANGE.