

INSTRUCTIONS FOR MODELS

SF-9100
SF-9200

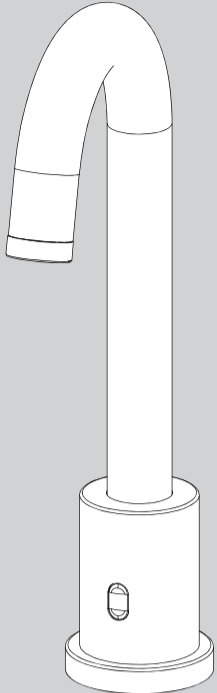

NEED HELP?

For additional assistance or service please contact:

SPEAKMAN®

800-537-2107

customerservice@speakman.com

www.speakman.com

92-SF-9100-02

TOOLS AND SUPPLIES

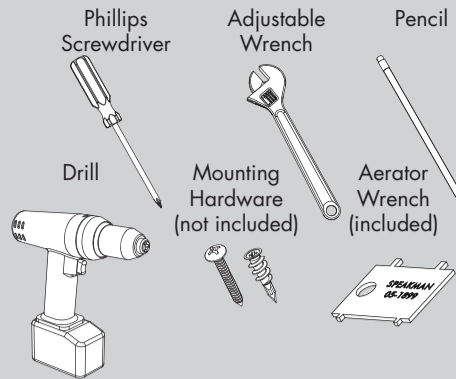

HELPFUL TOOLS & SUPPLIES:

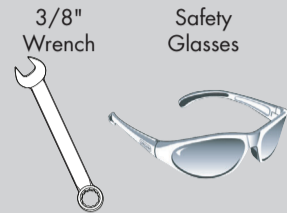

IMPORTANT

- Do not over-tighten any connections or damage may occur.
- Be sure to read instructions thoroughly before beginning installation.
- This faucet has an operating range of 20-80 psi.

SAFETY TIPS

Cover your drain to prevent loss of parts. Be sure to wear eye protection while cutting pipe.

MAINTENANCE

Your new Speakman Product is designed for years of trouble-free performance. Keep it looking new by cleaning it periodically with a soft cloth. The use of harsh chemicals and abrasives may damage the finish and void the product warranty. Please be sure to only use approved cleaners. Please contact Speakman for any clarification of acceptable cleaners.

WARRANTY

Warranty information can be found at: www.speakman.com

1 Verify that the Rubber Gasket is in position and aligned to the base of the Faucet.

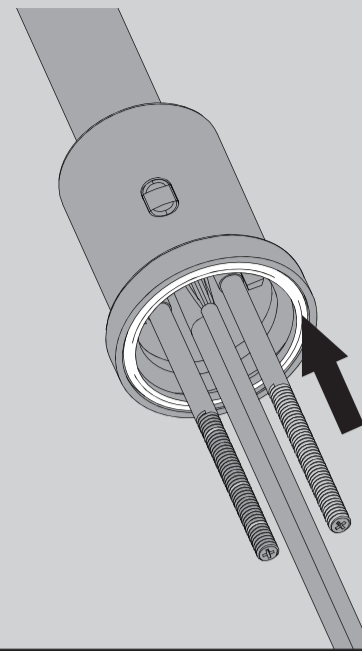

2 Place Hose and Sensor Wire carefully, one at a time, thru hole in mounting surface. Lower Faucet into position.

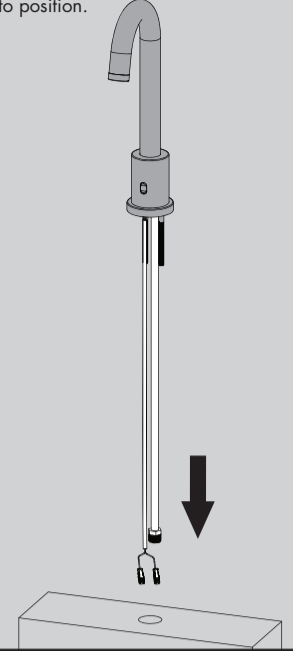

3 From below, install Rubber Washer (1), Metal Washer (2), and secure with Mounting Nuts (3). Align Faucet to desired position and wrench tighten Mounting Nuts (3).

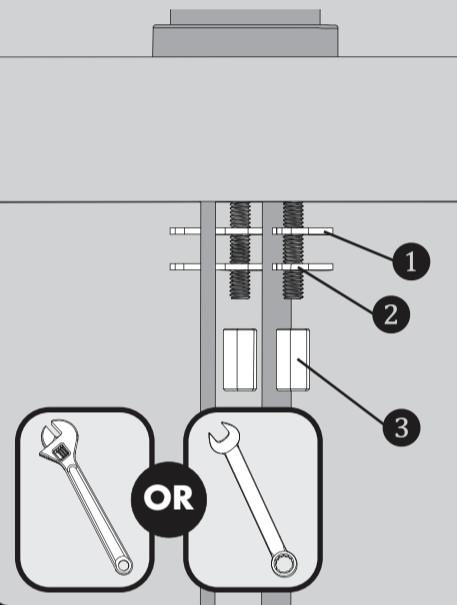

4 Assemble the Solenoid "OUTLET" Hose of the Faucet (1) to the "OUTLET" connection (2) of Solenoid. Wrench tighten.

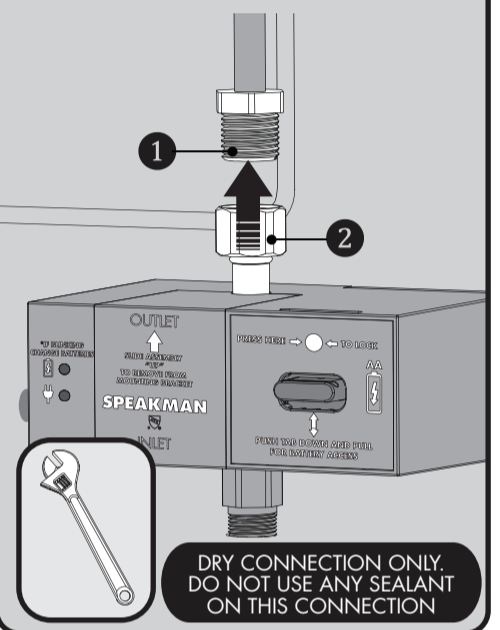

5 Place the Solenoid Assembly against the desired mounting surface while ensuring adequate clearance for servicing of all connections. If using the optional A/C Adapter, consider the distance to the nearest electrical outlet. Solenoid Assembly should be mounted so the inlet and outlet ports are aligned vertically. Mark location of Solenoid Assembly on the mounting surface using a pencil.

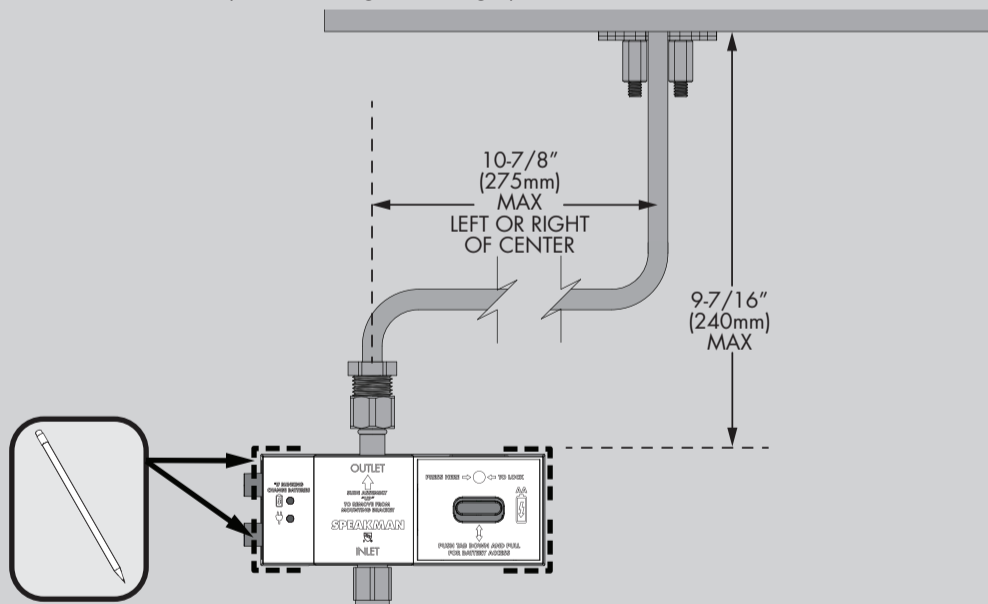

6 Remove Mounting Bracket (1) from Solenoid Assembly. Using the previously marked location on mounting surface, align Mounting Bracket (1) horizontally to approximate position and mark the mounting locations with a pencil. If mounting on drywall and not to stud, use the appropriate anchors and fasteners for application. Recommend screw in easy anchor or equal for drywall.

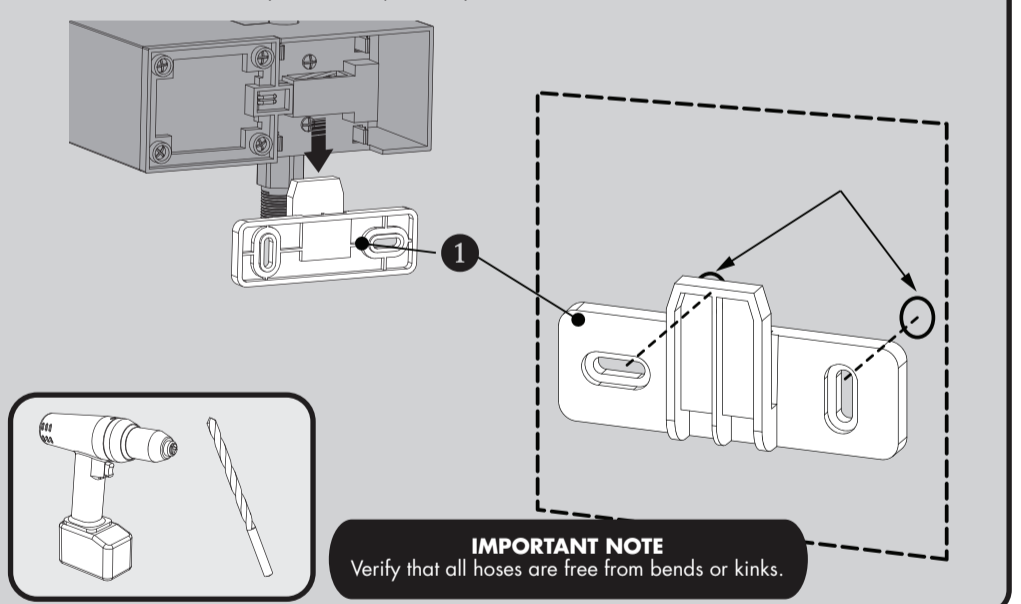

7 After securing the Bracket to the mounting surface, align and slide Solenoid Assembly over Mounting Bracket.

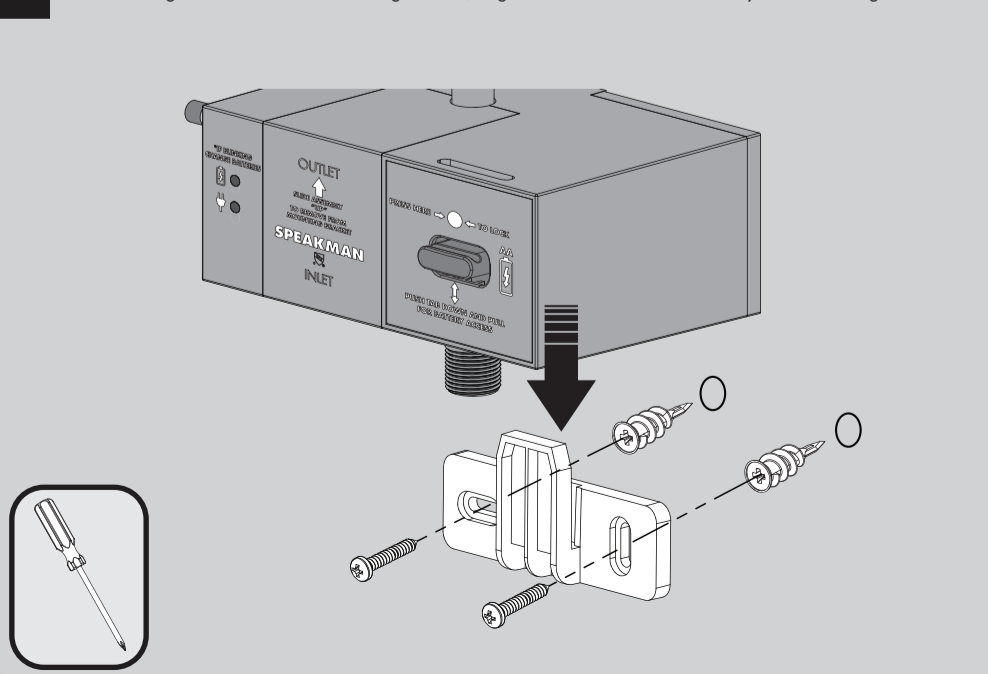

8 Assemble "INLET" Supply Hose (1) (not supplied), to the "INLET" connection (2) of Solenoid. Wrench tighten.

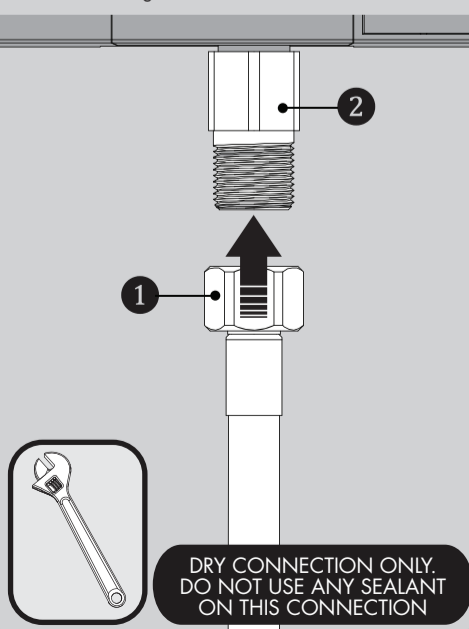

9 Make electrical connections from the Sensor Eye to the Solenoid Assembly. Connect the Blue Male Ended Wire to the Blue Female Connection. Connect the Green Male Ended Wire to the Green Female Connection. To further aid proper alignment, there are white alignment lines on the connector ends. These alignment lines should face forward when properly installed.

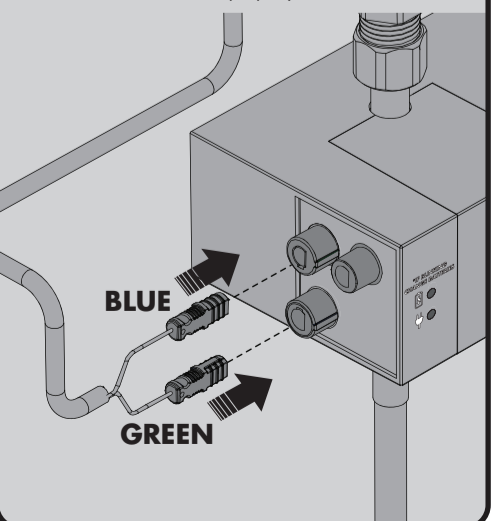

10 FOR BATTERY MODEL (SF-9100)

Access the interior Battery Enclosure by pressing down on the tab to release the tray holding the batteries (1). Pull out Battery Tray (2). Insert or replace the batteries with six (6) new standard 1.5v AA batteries. Ensure the position of the new batteries are aligned to the plus (+) and minus (-) symbols within the battery holder.

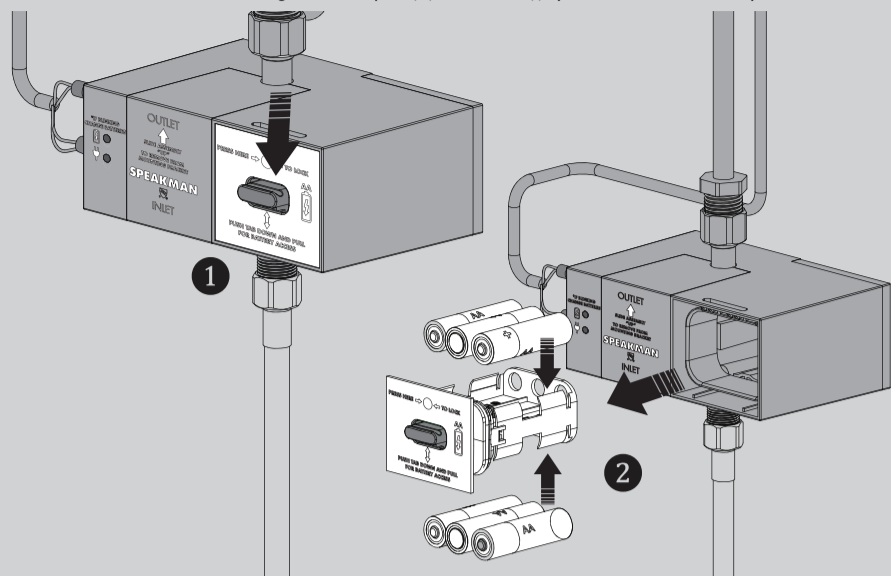

11 Reinstall the Battery Tray (1). Make sure to press the indicated location until the battery door is fully seated and locks into position (2).

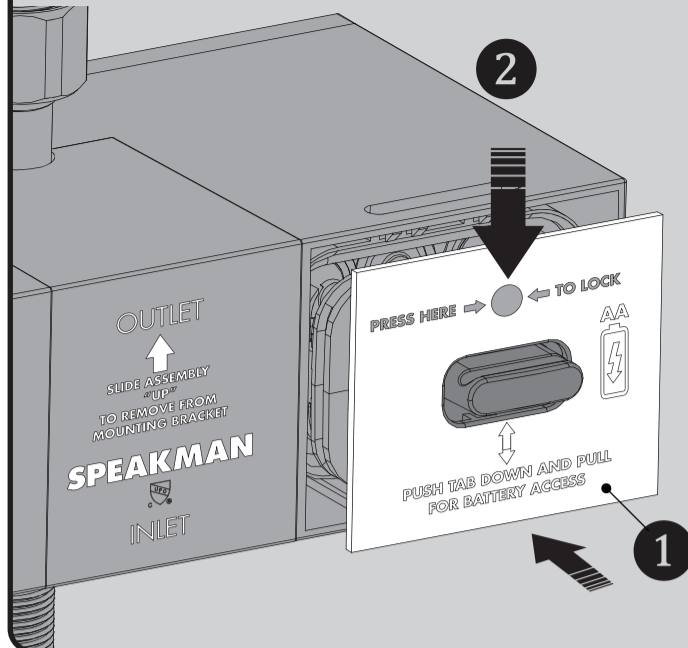

12 FOR A/C MODEL (SF-9200)

Verify that no batteries are present within the battery enclosure (1). Connect the A/C Adapter to the Solenoid Body (2). Plug the A/C Adapter into the wall outlet. The A/C light (3) should illuminate.

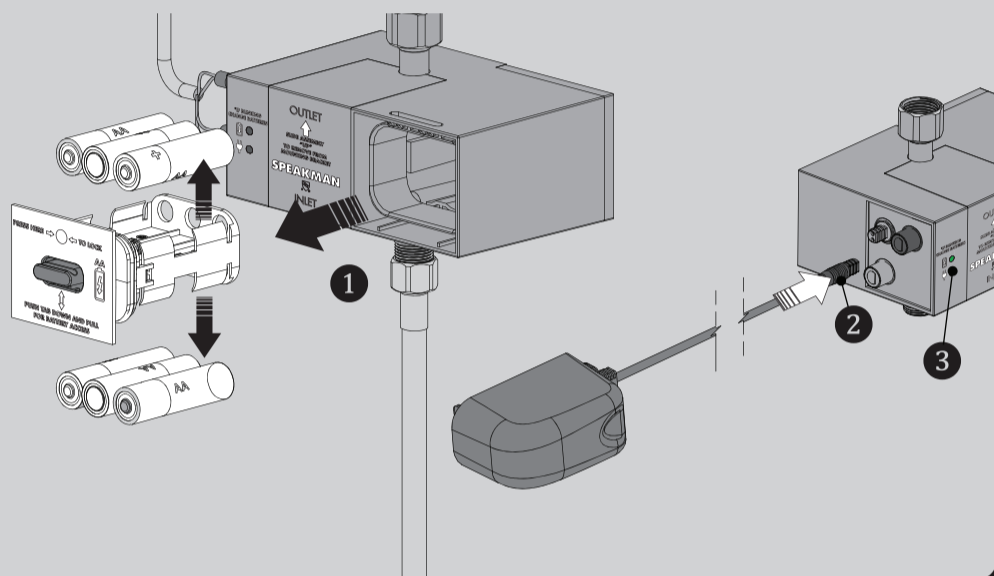

13 Turn on water supplies. Activate faucet by waving your hand across the Sensor Eye to flush the water for 1 minute.

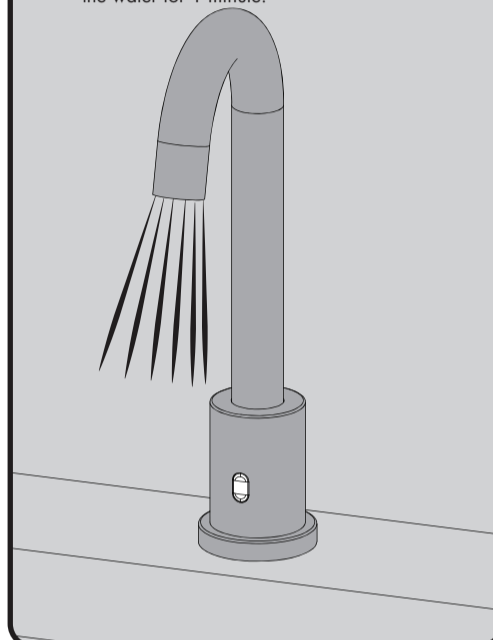

14 Install Aerator. Tighten with included Aerator Wrench.

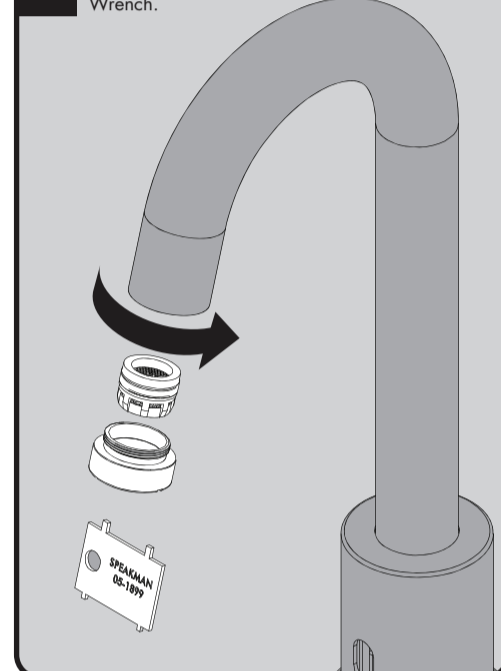

SF-9100 / SF-9200 TROUBLESHOOTING

If water flow from the Faucet decreases:

- 1) Make sure the supply stops are open.
- 2) Remove the Aerator from the spout using the outlet wrench. Operate the Faucet with outlet device removed. If water flow is acceptable, disassemble the outlet device and rinse components with clean water.

If no water flows from the Faucet, and

If you can hear a clicking sound of Solenoid opening, but no water flows:

- 1) Verify that the HOT and COLD wall stops are completely open.
- 2) If the Battery Light within the Sensor Eye or Solenoid blinks continuously, even when the Faucet is not in use, the batteries within the Solenoid have low voltage and need replacement.

If you **do not** hear a clicking sound of Solenoid opening and no water flows:

- 1) If the Battery Light within the Sensor Eye blinks continuously, even when the Faucet is not in use, the batteries within the Solenoid have low voltage and need replacement.
- 2) Unplug connections to Solenoid for 2 minutes. Plug connections back in. The red light on the Sensor should turn on for several seconds before becoming operational. If not, check power supplies and connections.
- 3) Disconnect the existing Solenoid Assembly and connect a new Solenoid Assembly. Activate the Sensor and check for water flow. If the water flows, the existing Solenoid Assembly should be replaced.

If the batteries have been replaced, but the Faucet still does not operate:

- 1) Check the battery polarity and electrical connections. Make sure all electrical connections are fully inserted.
- 2) If the Faucet does not operate, replace the existing Solenoid Assembly with one you know to be functioning.

If the Faucet activates, but the water will not shut off:

- 1) Hold a hand in front of the Sensor at up to 7" away for more than 1 minute until the water flow stops. Once the water stops, remove your hand and wait 15 seconds. Then place your hand in front of the Sensor and verify that it is operating properly.
- 2) If the Faucet still does not shut off, cover the front of the sink with a towel. This will eliminate the potential of reflections activating the Sensor.
- 3) If it is a new installation and still not working, replace the Solenoid Assembly.

SF-9100 / SF-9200 QUESTIONS & ANSWERS

Q. How does the Sensorflo® Faucet work?

A. It uses laser technology. The Sensor emits a non-visible beam of light. When an object enters the detection area, the Sensor signals the Solenoid Valve to open for water to flow. When an object leaves the detection area, the Sensor signals the valve to close.

Q. Is the Sensorflo® Faucet sensor beam adjustable?

A. No, the Sensorflo® Faucet sensor beam is not adjustable. It has been factory set to factory specifications for these Faucets.

Q. What about water conservation?

A. The Sensorflo® design directly addresses water conservation. Water savings of up to 85% are not unusual. Additional energy savings are realized by conserving hot water.

Q. Does Sensorflo® reduce maintenance?

A. By elimination of on/off handles, control components are reduced and fittings stay cleaner longer. Only a light rinsing and wiping is required to restore the beauty of the Sensorflo® Faucets. Drip stains are eliminated. Fingerprints and soap spots on sinks and fittings are avoided. Finishes last longer and wash areas stay cleaner. Germs and bacteria are not transferred as easily making for a healthier environment.

Q. The chrome finish on my Faucet seems to be deteriorating. What can I do to prevent this from happening?

A. Many commercial cleaning products contain harsh chemicals and abrasives. These products should not be used on any chrome-plated plumbing products. Please use only mild soap and water to clean the Faucet. Dry immediately with a soft cloth.

Q. Does the Sensorflo® system shut off immediately when an object leaves the sensing area?

A. A very short delay of approximately 0 to 1.5 seconds occurs before water is shut off.

Q. Is my Faucet protected from power surges?

A. Yes, Sensorflo® has been designed to have built-in power surge protection.

Q. If we lose power, do I have to do something to get the Faucet to operate again?

A. After a power outage, the Faucet is automatically ready for operation as soon as the power comes back on.

Q. If I call a plumber to come and install this Faucet, will they know enough to hook it up?

A. Our installation diagrams are very easy to follow.

SF-9100 / SF-9200 CARE AND CLEANING

1) Your SENSORFLO® Faucet is designed and engineered in accordance with the highest quality and performance standards. With proper care, it will provide years of hygienic and trouble-free service.

2) Periodically, the Faucet will require some minor maintenance to keep it at peak performance. There are 2 low battery indicator lights. One located on the Sensor on the Faucet body and the other located on the Solenoid Box. When the low battery light on the Sensor blinks, it indicates that the battery is low. However, the Solenoid can still function at this point. When the low battery light on the Solenoid blinks, the Solenoid will stop functioning at this point and the batteries need to be replaced immediately. To replace the batteries, follow the installation instructions in the electrical connections section of this document.

3) The polished chrome finish of your Faucet should be cleaned using mild soap and warm water.

4) Dry immediately with a soft, clean cloth for best results.

5) NEVER use abrasive cleaners, chemicals, alcohol or other solvents. They may damage the surfaces of the non-chrome plated finishes.

SF-9100 / SF-9200 REPAIR PARTS

SPEAKMAN®

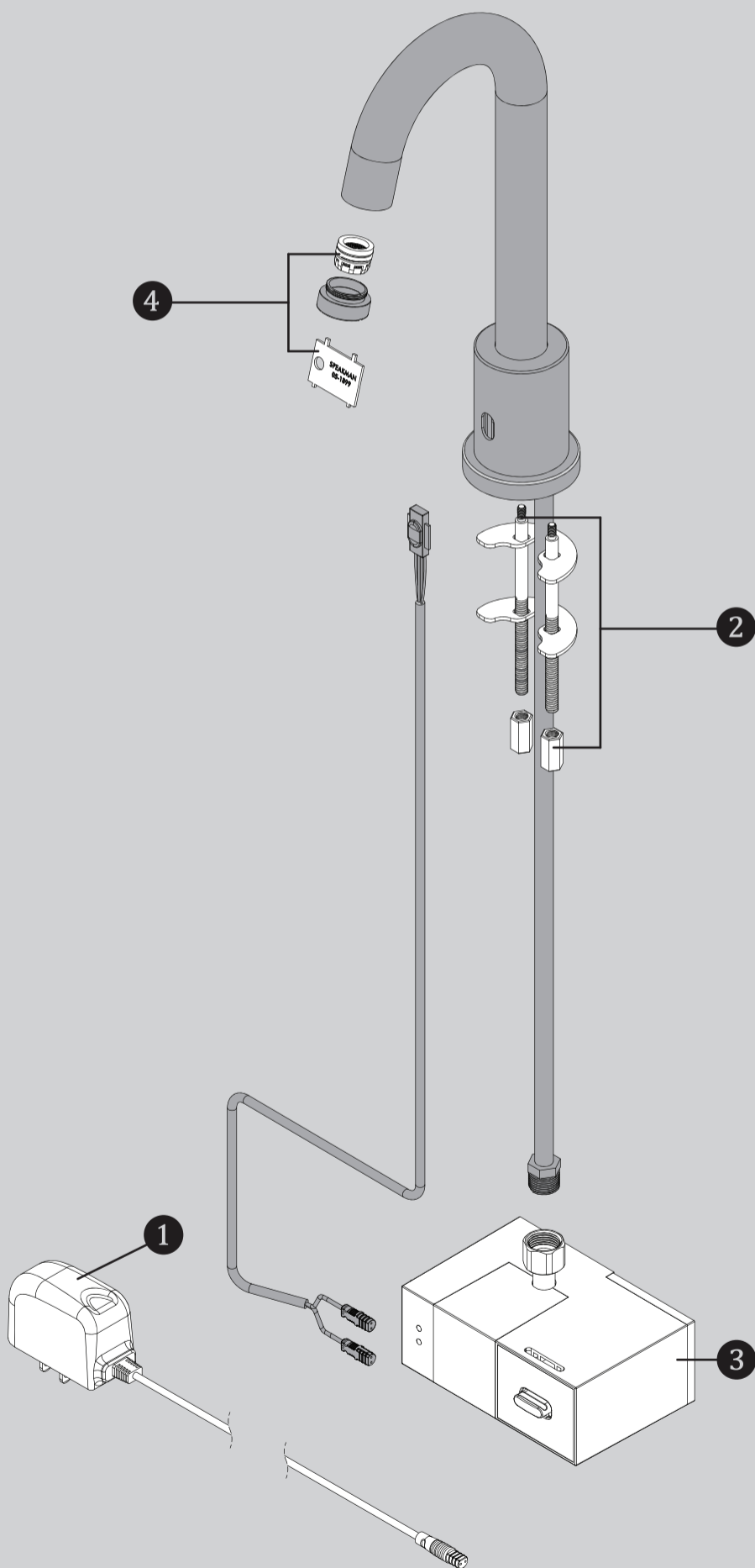

ITEM NO.	PART NO.	DESCRIPTION
1	RPG76-107259	TRANSFORMER 120VAC TO 6VDC
2	RPG45-110196	MOUNTING HARDWARE GROUP
3	RPG76-108060	SOLENOID ASSEMBLY (NO BATTERY)
4	RPG05-108059	0.5 GPM AERATOR REPAIR KIT

SF-9100 / SF-9200 ROUGH-IN DIAGRAM

SPEAKMAN®

NOTES:

COMPLIANCE:

ASME A112.18.1/CSA B 125.1

FLOW DATA:

- 0.5gpm (1.9 L/min)

CONNECTIONS:

Supply Connection:
9/16"-24 UNF Connection

LAVATORY ROUGH-IN

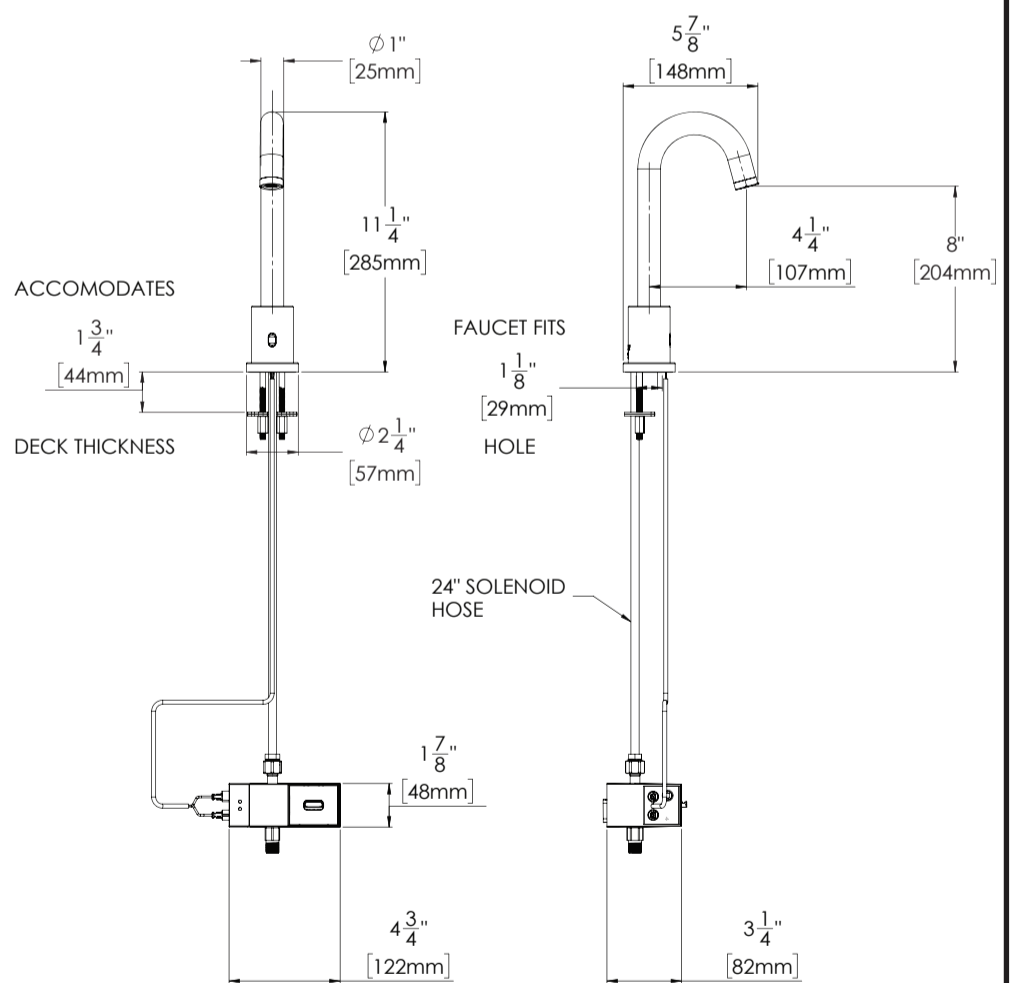
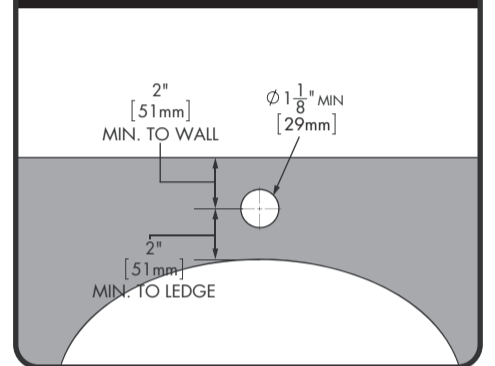

ALL DIMENSIONS ARE IN INCHES (MILLIMETERS) UNLESS OTHERWISE SPECIFIED. DIMENSIONS SUBJECT TO CHANGE WITHOUT NOTICE.

INSTRUCTIONS FOR MODELS

A-TMV Thermostatic Mixing Valve

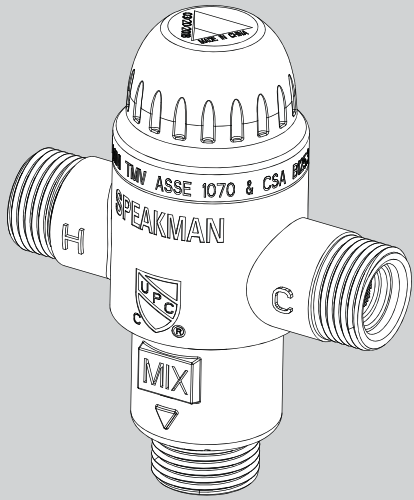

NEED HELP?

For additional assistance or service please contact:

SPEAKMAN®

800-537-2107

customerservice@speakman.com

www.speakman.com

92-A-TMV-02

TOOLS AND SUPPLIES

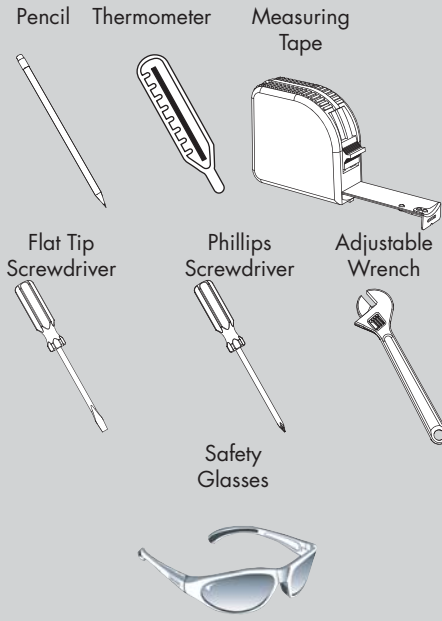

HELPFUL TOOLS & SUPPLIES:

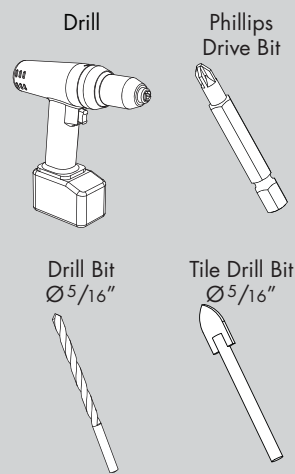

IMPORTANT

- Compliance and conformity to local codes and ordinances is the responsibility of the installer.
- Valve should be accessible for testing, adjustment and maintenance in the installed position.
- Make sure that all water supply lines have been flushed and then completely turned off before beginning installation. Debris in supply lines can cause valves to malfunction.
- Ensure the mounting structure and mounting hardware can safely support the product in use.
- Do not over-tighten any connections or damage may occur.
- Be sure to read instructions thoroughly before beginning installation.

IMPORTANT

SAFETY TIPS

Be sure to wear eye protection.

MAINTENANCE

See section "Testing the Mixing Valve".

WARRANTY

Warranty information can be found at:
www.speakman.com

- 1 Determine desired mounting position of the A-TMV with Plastic Wall Bracket. Ensure mounting location is capable of supporting the product in use. Using a pencil, mark the hole location.

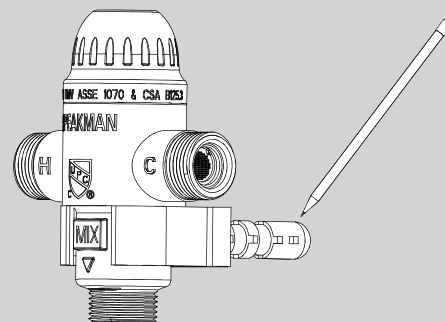

- 2 If mounting to drywall or tile, select appropriate 5/16" drill bit and drill guide hole at marked location. Install the Plastic Wall Bracket into the drilled hole and press/tap into place until the bracket is flush to the wall surface. Secure the Plastic Wall Bracket to the wall with the proper Mounting Screw (included).

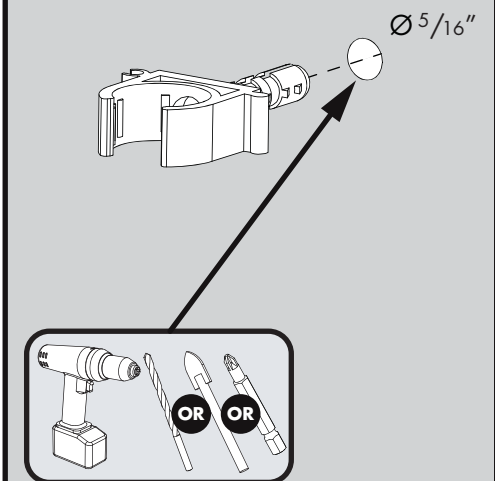

- 3 Ensure the A-TMV is vertical and the body rests on the top face of the Plastic Wall Bracket.

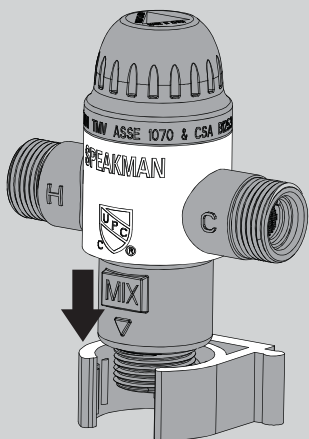

- 4 **Connect Supply Lines and Fixtures.**
 - Ensure incoming water supplies are turned OFF.
 - Install Inlet and Outlet connections to the valve. Wrench Tighten.

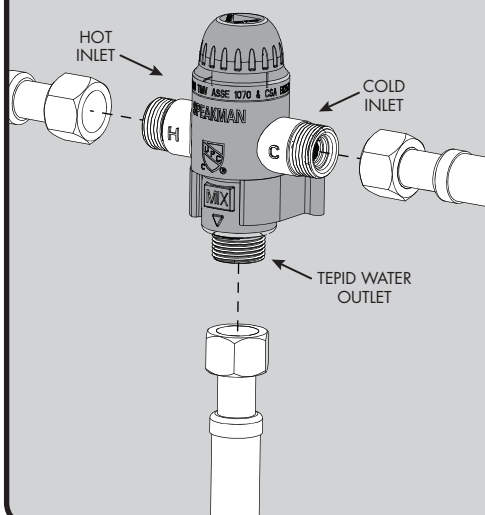

- 5
 - Check for leaks by pressurizing the unit SLOWLY.
 - Check the temperature and adjust if necessary.

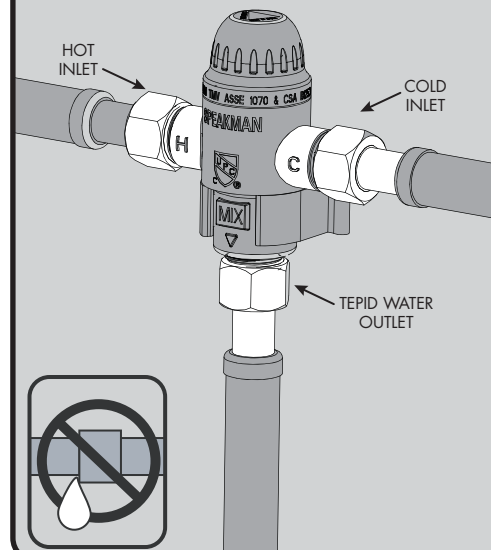

CAUTION

When maintaining and adjusting the Mixing Valve, all fixtures should be isolated from use. Speakman recommends that appropriate personnel shall work safely at all times.

6 SETTING THE MIXING VALVE

REMOVE THE CAP WITH FLAT TIP SCREWDRIVER FROM THE NOTCH ON THE CAP

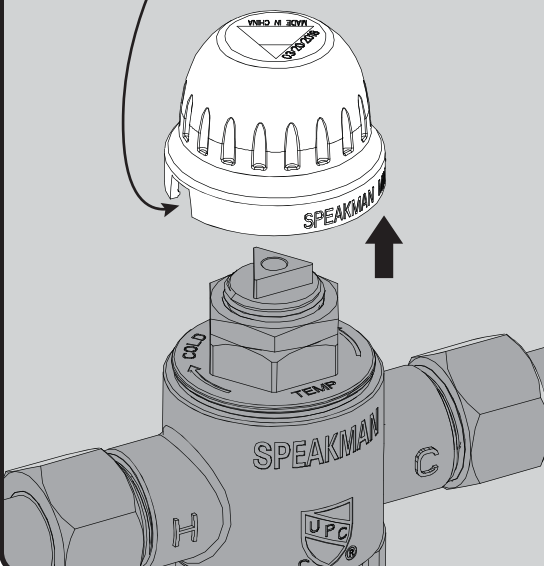

Should the Valve require adjustment, or an application require a different set temperature, proceed as follows:

Adjust Temperature with Water Running

- Check the temperature with a stick thermometer.
- Contact proper medical and safety authorities to determine the correct water temperature for the specific application.
- Remove the Plastic Cap (White) from the Valve using a flat tip screwdriver.

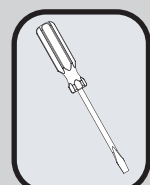

7 SETTING THE MIXING VALVE

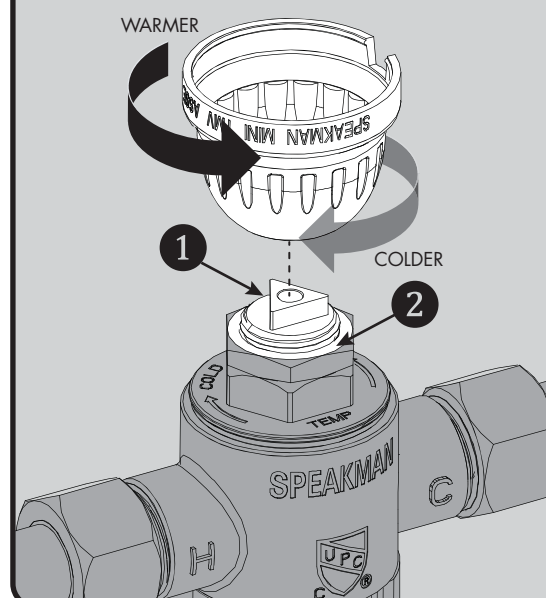

- Create a draw on the Mixing Valve by opening the faucet.
- Loosen, but do not remove the Locking Nut (2) using adjustable wrench. Invert Plastic Cap and align triangular recess in cap to the Adjuster Screw (1).
- Set the outlet temperature by turning the Adjuster Screw clockwise to reduce temperature, counterclockwise to increase temperature. Use a stick Thermometer to check the outlet temperature.
- Tighten the Locking Nut to avoid inadvertent adjustment of outlet temperature.

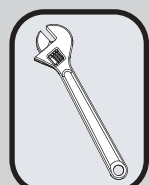
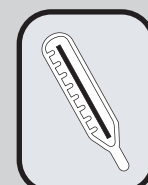

8 TESTING THE MIXING VALVE

After installation, test the Mixing Valve and the faucet it serves for proper operation by following the steps below.

Valve temperature test procedure is as follows:

1. Activate faucet to observe and record the temperature with a stick Thermometer. If the temperature of the Thermometer is not correct, readjust the Mixing Valve according to the section "Setting the Mixing Valve".

9 REPLACING THE THERMOSTATIC ELEMENT

The Thermostatic Element's replacement procedure is as follows:

1. Shut off the hot water supply and cold water supply to the Mixing Valve.
2. Remove the Plastic Cap and disassemble the Valve Cap.
3. Remove Thermostatic Element in conjunction with the Shuttle from the Valve Body. No special tools are required.
4. Inspect the Thermostatic Element. If it feels slippery to the touch, then the Element has lost its wax and requires replacement. If the Thermostatic Element feels normal to the touch, then it is in good condition and operable.
5. Verify that the stainless steel Piston moves freely up and down within the Element's body.

Note:

Gallon per minute ratings may vary depending upon incoming water temperatures and pressures. Hot and cold water inlet pressures must be equal.

Provisions shall be made to thermally isolate the valve.

A-TMV REPAIR PARTS

SPEAKMAN®

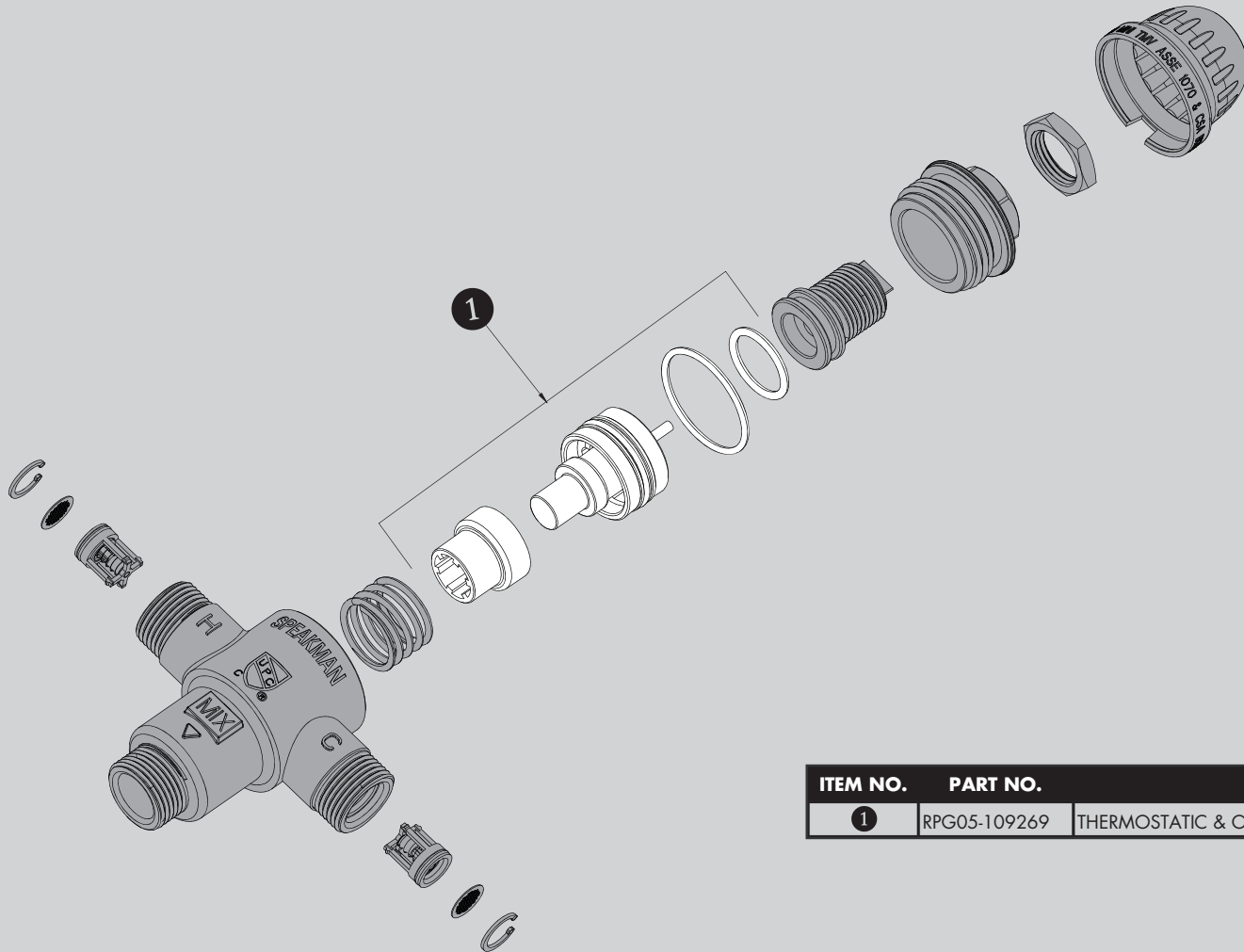

ITEM NO.	PART NO.	DESCRIPTION
1	RPG05-109269	THERMOSTATIC & O-RING REPAIR KIT

A-TMV ROUGH-IN DIAGRAM

SPEAKMAN®

NOTES:

COMPLIANCE:

ASSE 1070 & cUPC Certified

- Inlets: 3/8" Compression Male Threads
- Outlet: 3/8" Compression Male Threads
- Maximum Working Pressure: 125 psi (861.9 kPa)
- Rated flow at 30 psi (206.9 kPa) differential pressure: 2.16 GPM (8.2 L/min)
- Minimum flow rate: 0.35 GPM (1.3 L/min)
- Hot Water Inlet Temperature Range: 120° – 180° F
- Cold Water Inlet Temperature Range: 37° – 80° F
- Outlet Water Temperature Range: 80° – 120° F
- Minimum Temperature Differential (Hot to Mix): 18° F (10° C)

Contractor to supply necessary inlet connections.

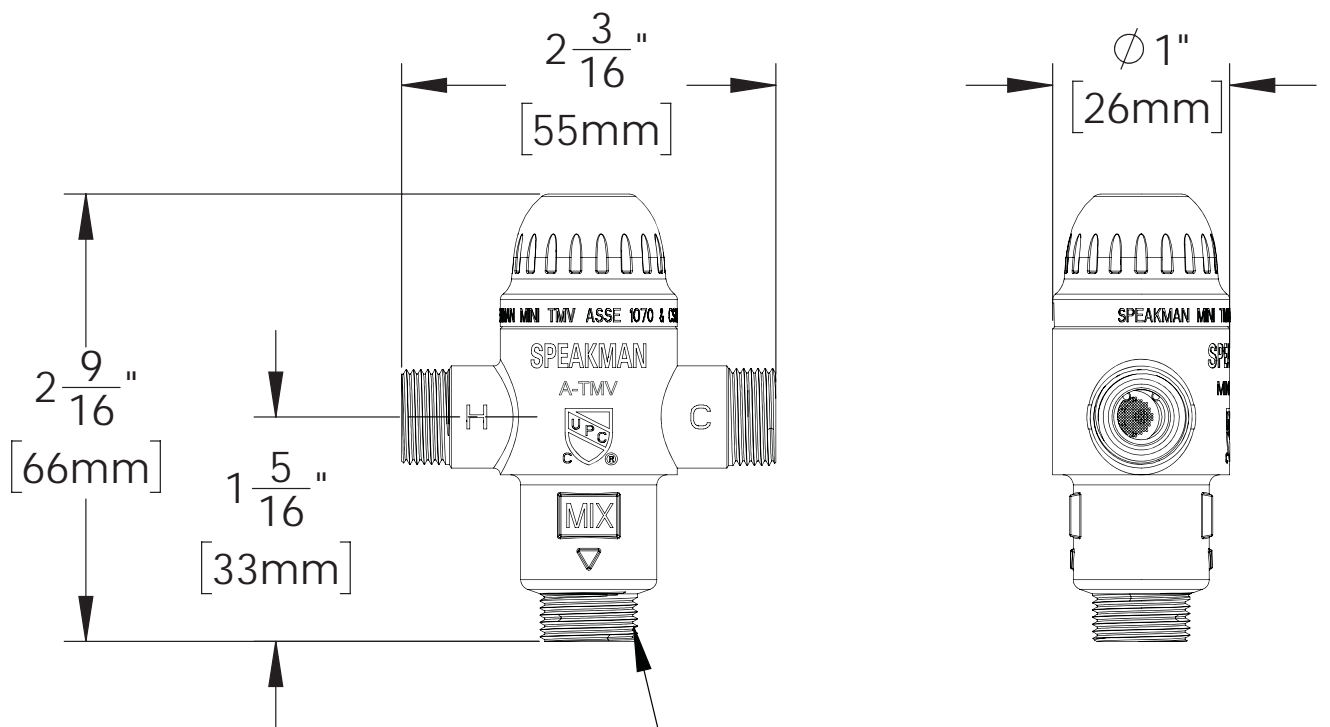

9/16"-24 THREAD FOR
3/8" COMPRESSION FITTINGS
(3 PLACES)

FLOW CAPACITY OF A-TMV

PRESSURE DROP,	psi (bar)	5	10	15	20	30	40	45	50
		(0.4)	(0.7)	(1.0)	(1.4)	(2.1)	(2.8)	(3.1)	(3.4)
TEMPERED FLOW,	GPM (L/min)	0.66 (2.5)	1.2 (4.5)	1.5 (5.7)	1.74 (6.6)	2.16 (8.2)	2.51 (9.5)	2.66 (10.1)	2.8 (10.6)

NOTES:

1. ALL DIMENSIONS ARE IN INCHES [MILLIMETERS] UNLESS OTHERWISE SPECIFIED AND ARE SUBJECT TO CHANGE.