

SPEAKMAN® SE-573-SD

Optimus® Laboratory Deck-Mounted Eyewash

FEATURES:

- 16 in. Arm. ADA Compliant
- Deck-mounted
- (2) Aerated Optimus spray heads with integrated dust caps
- Brass, chrome-plated valve
- Swing activated
- ½ in. NPT male inlet
- 2.6 gpm @ 30 psi
- Universal emergency sign included

FINISH:



Chrome

COMPLIANCE:

- ANSI/ISEA Z358.1 certified

OPTIONS:

Add suffix to model #

- In-line strainer for ½ in. IPS piping ILS

WARRANTY:

- 3 year limited



DIMENSIONS:

NOTE: 1. All dimensions are in inches (millimeters) unless otherwise specified and are subject to change without notice.

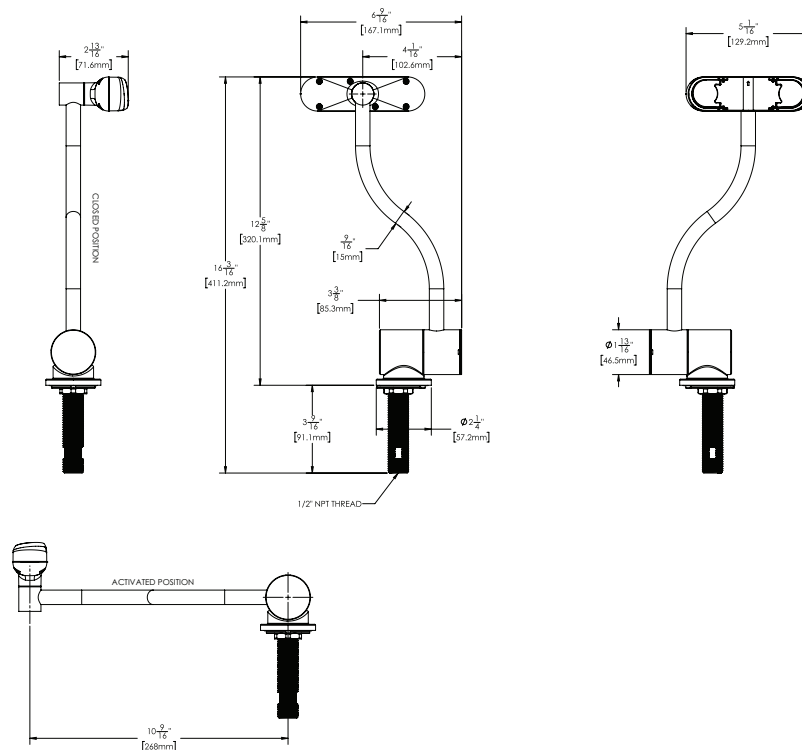

Architect/Engineer Approval Space:

SPEAKMAN
400 ANCHOR MILL ROAD
NEW CASTLE, DE 19720

P: 800-537-2107
F: 800-977-2747
W: WWW.SPEAKMAN.COM
R: FEBRUARY 2018