

# SPEAKMAN® S-2256-E2

## Icon™ Shower Head

### FEATURES:

- 6 plungers, 48 sprays
- Solid brass construction
- Spray adjusting handle
- 1/2 in. NPT inlet
- Patented plungers resist scale buildup
- 2.0 gpm (7.6 L/min) flow rate

### FINISH:



PC

### COMPLIANCE:

- ASME A112.18.1/CSA B125.1 compliant
- WaterSense certified



### WARRANTY:

- Limited Lifetime Warranty (consumer use)
- 1 Year Limited (commercial use)

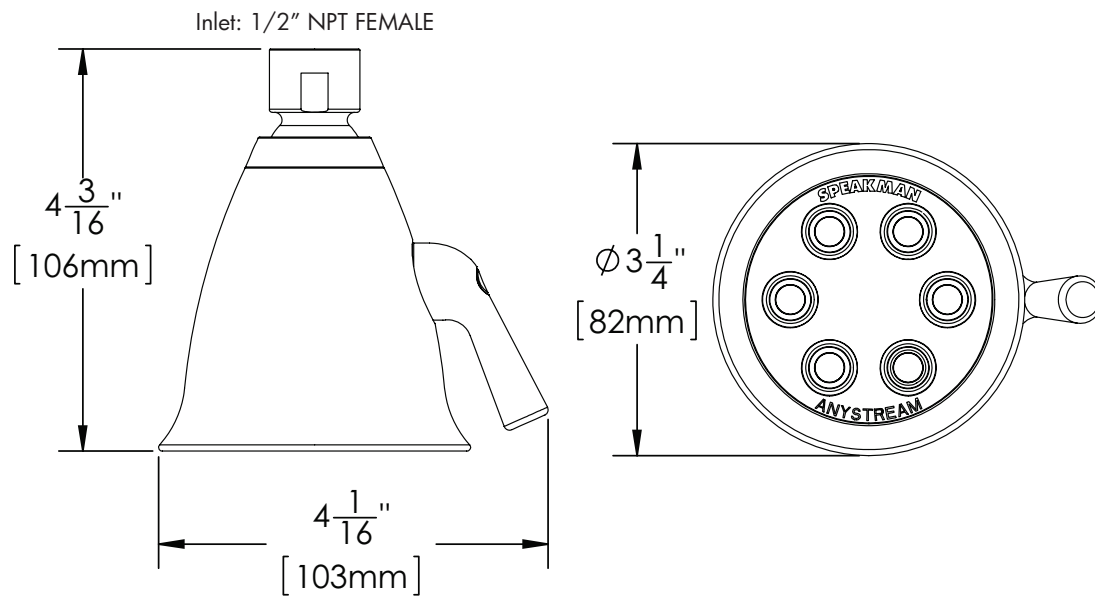

### DIMENSIONS:

 NOTE: 1. All dimensions are in inches (millimeters) unless otherwise specified and are subject to change without notice.

Architect/Engineer Approval Space:

SPEAKMAN  
400 ANCHOR MILL ROAD  
NEW CASTLE, DE 19720

P: 800-537-2107  
F: 800-977-2747  
W: WWW.SPEAKMAN.COM  
R: MAY 2017