

SPEAKMAN® S-2005-HBF

Hotel™ Pure Shower Head

FEATURES:

- 5 plungers, 50 sprays
- 8 center massage jets
- Spray adjusting handle
- 1/2 in. NPT inlet
- 10,000 gallon/6 month filter life
- FS-1 is the replacement filter cartridge
- 2.5 gpm (9.5 L/min) flow rate

FINISH:



PC BN

OPTIONS:

Add suffix to model #

- 2.0 gpm (7.6 L/min) flow rate -E2

COMPLIANCE:

- ASME A112.18.1/CSA B125.1 compliant
- WaterSense certified (E2)



WARRANTY:

- Limited Lifetime Warranty (consumer use)
- 1 Year Limited (commercial use)



S-2005-HBF



FS-1

DIMENSIONS:

NOTE: 1. All dimensions are in inches (millimeters) unless otherwise specified and are subject to change without notice.

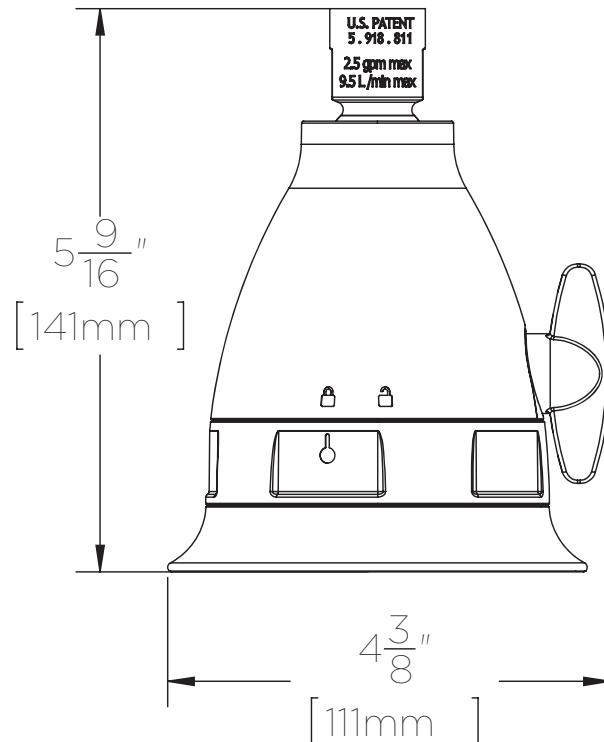
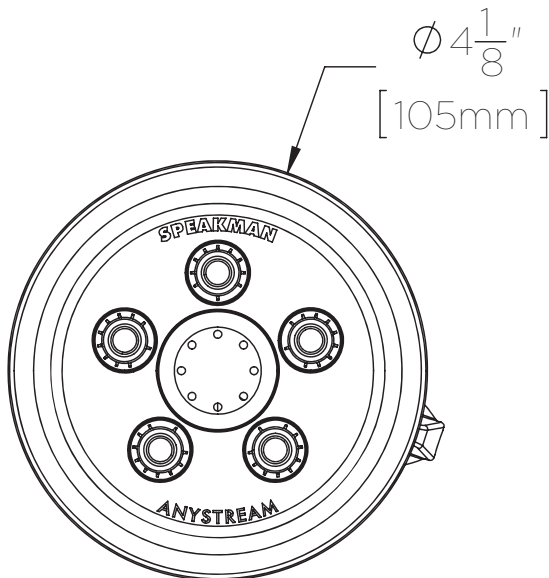

Architect/Engineer Approval Space:

SPEAKMAN
400 ANCHOR MILL ROAD
NEW CASTLE, DE 19720

P: 800-537-2107
F: 800-977-2747
W: WWW.SPEAKMAN.COM
R: DECEMBER 2016