

Sensorflo® AC Powered Lavatory Faucet

MODELS:

- ❑ S-8817-CA-E: Low profile faucet with 4 in. deck plate.
- ❑ S-8818-CA-E: Low profile faucet with 4 in. deck plate, under counter mechanical mixer with built-in backflow check valves.
- ❑ S-8827-CA-E: Low profile faucet with 8 in. deck plate.
- ❑ S-8828-CA-E: Low profile faucet with 8 in. deck plate, under counter mechanical mixer with built-in backflow check valves.

FEATURES:

- Ceramic manual override valve activates the faucet for continuous operation in the event of battery drain or user preference.
- Solenoid with built-in filter.
- Includes hoses needed to make manual override connections.
- UL/CSA approved transformer 120 VAC to 12 DC with waterproof connectors.
- Lead-free construction.
- Spout consists of all metal chassis and removable cover.
- Vandal resistant 60-second time out feature.
- Water conserving vandal-resistant flow control reduces flow to 0.5 gpm (1.89 L/min).
- NOTE: Stainless steel flexible supply hose(s), 3/8 in. compression, to supply stop(s) not included, see add-ons below.

COMPLIANCE:

- ASME A112.18.1/CSA B125.1 certified
- NSF 61 certified
- NSF 372 certified

FINISH:



PC

ADD-ONS:

- 0.5 gpm Boca spray outlet & 1.5 gpm laminar flow outlet kit A-BOLF
- Two (2) stainless steel flexible supply hoses to supply stops A-HS
- One (1) stainless steel hose for tempered water systems (S-8817, S-8827 only) A-HTS
- Under counter thermostatic mixing valve A-TMV
- Vandal-resistant screws for removable cover and custom wrench A-VRS
- 1.2 gpm laminar flow outlet A-ELF
- 1.2 gpm aerator A-EA12
- Tee with integral check valves A-TEE

OPTION: Add suffix to model

- Less transformer -LT

WARRANTY:

- 5 Year Limited

S-8817-CA-E
S-8818-CA-E



S-8827-CA-E
S-8828-CA-E



DIMENSIONS: NOTE: 1. All dimensions are in inches (millimeters) unless otherwise specified and are subject to change without notice.
 2. Inlet is 3/8" compression with male threads. Position faucet as close to the edge of the sink as possible.

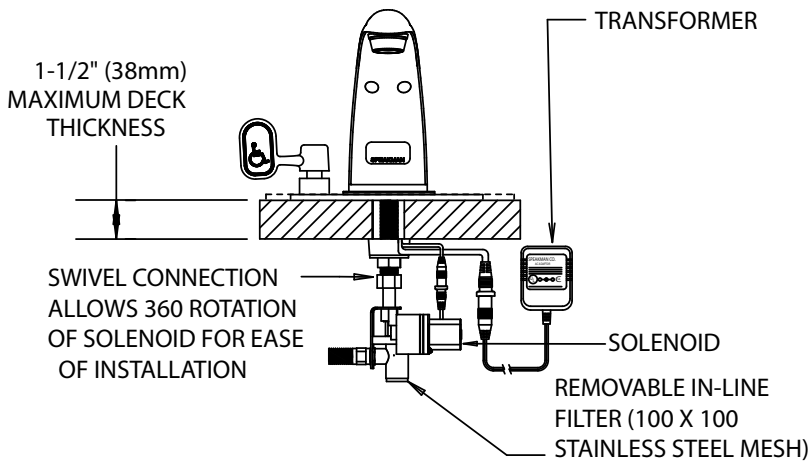

S-8817-CA-E
 S-8818-CA-E

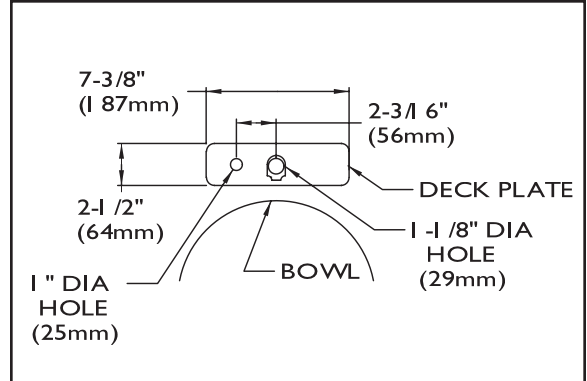

S-8827-CA-E
 S-8828-CA-E

