

SCS5 - Speed Control Slide

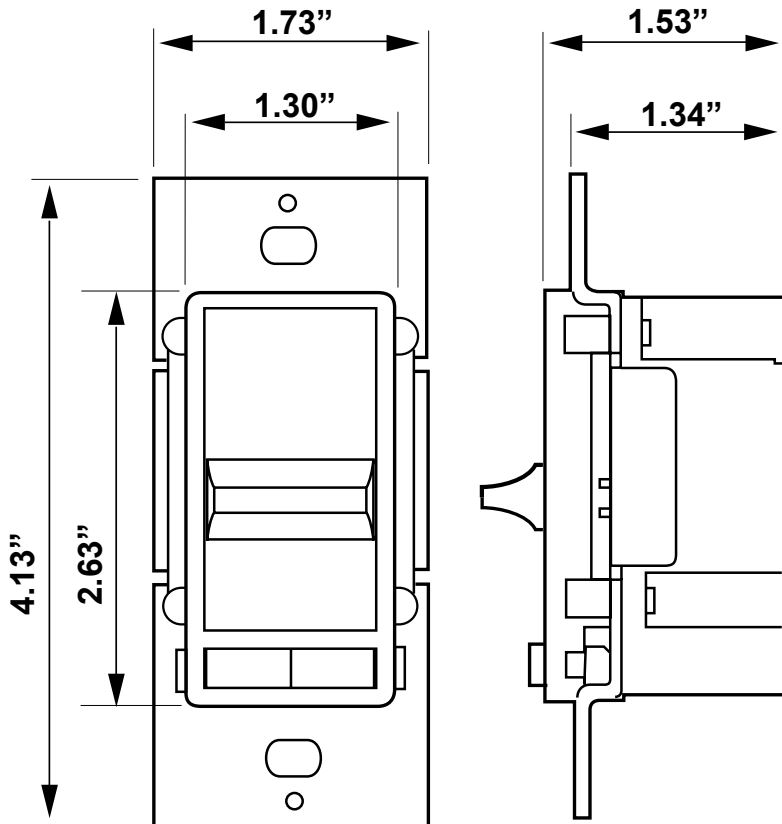

The World's Leading Producer of
Air Movement Products
 6393 Powers Avenue
 Jacksonville, Florida 32217-2298
 P: 800.961.7370 F: 800.961.7379
 www.solerpalau-usa.com



Features:

Switch Type: Single-Pole
 Timer Type: SureSlide
 Type: Electro-Mechanical
 Load Type: Incandescent
 Load Rating: 600W
 Voltage: 120 Volt AC 60Hz
 Action: Standard ON/OFF
 Protection: Radio/TV Filter
 Color: White

ACCESSORY MODEL	1	2	3	4	5	REMARKS

PROJECT: _____ CONTRACTOR: _____
 LOCATION: _____ REVISION DATE: _____
 FORM NO.: _____ SUBMITTED BY: _____ DATE: _____
 ENGINEER: _____ APPROVED BY: _____ DATE: _____

For more information contact us at www.solerpalau-usa.com or 1.800.961.7370 for additional submittal drawings.

Soler & Palau will not be responsible for fabrication changes or errors resulting from customer use of a non-current submittal drawing.

