



ARE & ARS Dome Axial Power Roof Ventilators

Direct Drive Exhaust & Supply

Catalog ARE/ARS01-July 2007



The World's Leading Producer of
Air Movement Products

Soler&Palau
Ventilation Group

COMMERCIAL PRODUCT LINE



Application

The AR series offers powerful axial intake (ARS) or exhaust (ARE) performance in a roof mount design that is compact, lightweight and easy to install. Available in 5 sizes with a CFM range from 268 to over 3100 CFM to .75 static pressure.

The direct drive design has no belts or fan bearings to maintain or adjust and consequently requires very little maintenance. The AR series is an excellent choice for factories, shops, restaurants, bathrooms, offices, schools and other similar applications where light to moderate static pressures are present. Equipped with explosion-proof motors, the AR series can be used in more severe applications. (Caution should be used to safely match the motor capabilities with the specific hazardous environment).

The low contour designs and all aluminum housing provides a modern, clean appearance in addition to excellent performance and durability.

Construction/Specification Checklist

Housing

- Heavy-gauge all aluminum housing.
- Exclusive U-Spring suspension compensates for both radial and lateral movement and provides 44% better vibration isolation than rubber isolators.
- External wiring chase for easy connection.
- High point of discharge with low silhouette design.
- Quick access to motor compartment for easy maintenance.

Propellers

- Attaches directly to fan shaft for maximum efficiency.
- Precision pitched. Heavy-gauge aluminum blades with steel hub. Blades are designed for specific exhaust or supply requirements.

Motors

- Standard motors are single speed, speed controllable and drip-proof.
- All motors are rated for continuous duty.
- Disconnect is standard on ODP motors (except two speed and explosion proof).
- Motors are shipped assembled with factory test run assurance.

Certifications

- UL-705 listing available as an option on units with standard motors.
- Units are tested in accordance with AMCA 301 (Sound) and AMCA 210 (Air) in an AMCA certified laboratory.

Options/Accessories

- Backdraft dampers.
- Roof curbs/hinged curb caps.
- UL-705 listing.
- Stainless steel hardware.
- Insect screen.
- Explosion-proof motors.
- Special coatings: Epoxy, Heresite and Eisenheiss.

Optimizer Selection Program

Please refer to Soler & Palau USA's Optimizer Program for fan curve, submittal information and other details of the AR series and other Soler & Palau products. Contact your representative or factory for a copy. Visit Soler & Palau's website for additional information: www.solerpalau-usa.com.

Quickship Program

Most AR Models and optional accessories are available on the Soler & Palau Quickship Program. This program provides rapid delivery of standard products so that tight project deadlines can be met and downtime on replacement work can be held to a minimum.

All specifications are subject to change without notice unless approved in submittal by Soler & Palau USA.



Standard 705
(Optional)



Model ARE (Exhaust)

CFM / BHP @ Static Pressure / Sones								Catalog Number	HP	RPM	Sones @ 0"SP	Max BHP
0	1/10	1/8	1/4	3/8	1/2	5/8	3/4					
495	322	268	-	-	-	-	-	ARE 100A S	1/15	930		.014
655	532	498	316	-	-	-	-	ARE 100A S	1/15	1230	4.2	.033
825	730	570	405	-	-	-	-	ARE 100A *	1/15	1550		.067
793	417	365	-	-	-	-	-	ARE 121A S	1/4	685		.027
1088	914	818	478	375	-	-	-	ARE 121A S	1/4	940	4.1	.070
1320	1224	1190	730	570	320	-	-	ARE 121A *	1/4	1140		.125
1173	1035	975	600	-	-	-	-	ARE 120A S	1/4	1030		.053
1566	1450	1430	1163	866	-	-	-	ARE 120A S	1/4	1375	6.1	.127
2000	1857	1840	1760	1570	1160	1060	970	ARE 120A *	1/4	1725		.250
1226	796	700	-	-	-	-	-	ARE 161A S	1/4	685		.036
1682	1378	1297	926	-	-	-	-	ARE 161A S	1/4	940	4.5	.094
2040	1796	1730	1400	1110	930	-	-	ARE 161A *	1/4	1140		.167
1827	1572	1549	1114	-	-	-	-	ARE 160A S	1/3	1030		.071
2439	2187	2149	2045	1704	-	-	-	ARE 160A S	1/3	1375	9.5	.169
3060	2863	2810	2650	2580	2410	2020	1800	ARE 160A *	1/3	1725		.333
1911	1442	1318	-	-	-	-	-	ARE 201A S	1/4	685		.054
2622	2343	2256	1776	-	-	-	-	ARE 201A S	1/4	940	6.9	.140
3180	2963	2900	2530	2140	1980	-	-	ARE 201A *	1/4	1140		.250

* - As run speed.
S - Requires speed control.

Model ARS (Supply)

CFM / BHP @ Static Pressure / Sones								Catalog Number	HP	RPM	Sones @ 0"SP	Max BHP
0	1/10	1/8	1/4	3/8	1/2	5/8	3/4					
615	423	351	-	-	-	-	-	ARS 100A S	1/15	1230		.033
694	576	547	231	-	-	-	-	ARS 100A S	1/15	1390	4.0	.042
775	644	610	325	-	-	-	-	ARS 100A *	1/15	1550		.067
769	512	-	-	-	-	-	-	ARS 121A S	1/4	820		.046
882	588	509	-	-	-	-	-	ARS 121A S	1/4	940	4.1	.070
1070	833	770	440	-	-	-	-	ARS 121A *	1/4	1140		.125
943	697	588	-	-	-	-	-	ARS 120A S	1/4	1030		.053
1259	1082	1040	706	429	-	-	-	ARS 120A S	1/4	1375	6.1	.127
1580	1433	1400	1230	920	700	470	-	ARS 120A *	1/4	1725		.250
1309	781	-	-	-	-	-	-	ARS 161A S	1/4	820		.062
1501	895	842	394	-	-	-	-	ARS 161A S	1/4	940	4.5	.094
1820	1360	1130	920	450	-	-	-	ARS 161A *	1/4	1140		.167
1505	1171	1069	691	-	-	-	-	ARS 160A S	1/3	1030		.071
2009	1815	1742	1355	1028	-	-	-	ARS 160A S	1/3	1375	9.5	.169
2520	2383	2340	2040	1735	1500	1070	-	ARS 160A *	1/3	1725		.333
1767	1343	1223	-	-	-	-	-	ARS 201A S	1/4	685		.054
2424	2123	2047	1626	-	-	-	-	ARS 201A S	1/4	940	6.9	.140
2940	2692	2630	2310	1950	1580	-	-	ARS 201A *	1/4	1140		.250

* - As run speed.
S - Requires speed control.

Soler & Palau USA certifies the performance shown herein. The ratings shown are based on tests and procedures performed in accordance with AMCA Publication 210 (Air) and AMCA 301 (Sound).

Dimensional Data

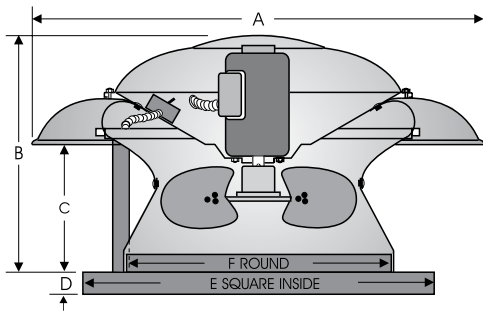

Size	Dimensions (Inches)						Avg. Ship weight (lbs.)
	A	B	C	D	E	F	
100A	21	13	7	2	20	13-3/4	25
120A-121A	28	16	8	3	24	15-3/4	42
160A-161A	32	18	8-1/2	3	28	19-3/4	55
201A	36	20	9-3/4	3	32	23-3/4	75



Standard 705
(Optional)

Typical Specification

Axial direct drive power roof ventilator shall be Model ARE (Exhaust) or Model ARS (Supply) as manufactured by Soler & Palau USA, Jacksonville, Florida.

Spun aluminum housing, venturi, and curb cap shall be heavy-gauge aluminum construction. Curb cap corners shall be welded not staked.

Aluminum propeller shall have steel hub and be statically and dynamically balanced and keyed to the motor shaft. Motor and propeller shall be mounted on a U-spring Suspension System for radial and axial vibration isolation. Rubber isolators are not acceptable.

Motors shall be of nationally recognized manufacturer with permanently lubricated bearings and provided with the specified voltage, phase, and enclosure. A wiring chase shall be provided for ease of electrical connection to the factory provided disconnect switch.

Fans will be available UL-705 listed and tested in accordance with AMCA 301 (Sound) and AMCA 210 (Air).

SOLER & PALAU USA LIMITED WARRANTY

Soler & Palau USA (manufacturer), 6393 Powers Avenue, Jacksonville, Florida 32217, warrants equipment of its manufacture to be free from defects in design, materials and workmanship (exclusive of abrasion, corrosion or erosion) for one (1) year from the date of shipment to the original purchaser or the date of notification of readiness to ship. Motor warranty is one (1) year. In order to claim the benefit of this warranty, buyer must notify manufacturer in writing of the claimed defect within ten (10) days after discovering it and return this equipment or parts to the factory with transportation prepaid. In the event of on-site repair, no service technician will be dispatched until manufacturer receives your written purchase order. If any of the following conditions exist, the warranty will be null and void: **(1)** Buyer has permitted other persons not approved or authorized by manufacturer to alter, adjust, replace or repair the equipment or any part thereof. **(2)** Buyer has not followed instructions or other directions given in the contract documents or our maintenance manual. **(3)** When breakage or other loss or damage is the result of any negligence, misuse or fault on the part of any operator or other person not under our supervision or control. **(4)** The defect is the result of designs or drawings made, furnished or specified by others. **(5)** In the case of goods not manufactured but supplied by the manufacturer as part of a contract, manufacturer shall only be liable to the same extent that our supplier is to manufacturer, not to exceed any liability manufacturer would have for warranty on our own equipment. **(6)** Buyer has not paid in full any invoices submitted to buyer which are due for payment. **(7)** Unusual wear and tear of the equipment. Statements relating to the product, its use or installation made prior to the execution of the agreement, are not warranties except to the extent that the contrary is expressly set forth herein. It is understood that such statements were not intended to, and did not, form a part of the agreement; they were merely made in the course of negotiations of the parties. **THIS WARRANTY IS IN LIEU OF ANY OTHER EXPRESS OR IMPLIED WARRANTIES, INCLUDING ANY IMPLIED WARRANTY OF MERCHANTABILITY OR FITNESS FOR ANY PARTICULAR PURPOSE. OUR SOLE AND EXCLUSIVE OBLIGATION UNDER THIS WARRANTY IS TO REPAIR OR REPLACE DEFECTIVE EQUIPMENT OR PARTS OR, AT OUR OPTION, TO PAY THE REASONABLE COST OF REPAIR OR REPLACEMENT. BUYER AGREES THAT NO OTHER REMEDY (INCLUDING, BUT NOT LIMITED TO, INCIDENTAL OR CONSEQUENTIAL DAMAGES, DAMAGES FOR LOST PROFITS OR SALES, OR DAMAGES FOR INJURIES TO PERSON OR PROPERTY) SHALL BE AVAILABLE. NOTWITHSTANDING THE ABOVE, THE TOTAL AMOUNT THAT MAY IN ANY EVENT BE PAYABLE IN SETTLEMENT OF LIABILITY, HOWEVER INCURRED, SHALL NOT EXCEED THE CONTRACT PRICE.**

DUE TO CONTINUING RESEARCH SOLER & PALAU USA RESERVES THE RIGHT TO CHANGE SPECIFICATIONS WITHOUT NOTICE

Distributed By:



Soler & Palau USA
6393 Powers Avenue
Jacksonville, FL 32217
800.961.7370
800.961.7379
www.solerpalau-usa.com

Soler & Palau Canada
61 A Baywood Road
Toronto, ON M9V 3Y8
866.733.0233
866.358.5346
www.solerpalaucanada.com