



Centrifugal Spun Aluminum Products



SDB • SDBD • STXB • STXD

Downblast & Upblast Centrifugal Roof and Wall Exhausters

*Designed with **Efficiency** in Mind*

Centrifugal Spun Aluminum Line Overview

When we started the project to improve our upblast and downblast spun aluminum power roof ventilators we set fan efficiency as our number one goal. We knew the wheel, the heart of the unit, was the place to start so we took meticulous steps to design and engineer the most efficient and cost effective wheel we could. Our new wheel features curved blades, solid rivets and improved cooling vanes which together ensure the best fan performances possible.

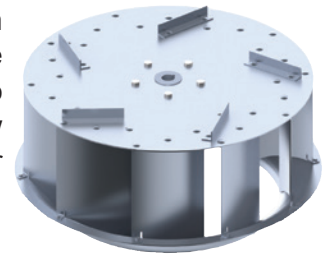

Since efficiency was a key factor in the design we looked to increase our manufacturing efficiency to save on costs and ultimately save you, the customer, money. Commonizing parts, improving manufacturing processes and creating a more robust product not only created a lower priced unit, but also lowered the operating cost over the lifetime of the product. Additionally, through improvements to important structural components of the fans we increased the overall strength of our centrifugal fans compared to our older models*. We are proud to say we have created a product line that you can be sure is one of the most efficient and robust available on the market today.

Efficient Engineering, Manufacturing and Performance

- Wheels feature curved blade design for more CFM per HP and lower sound levels
- Airflow analysis using Computational Fluid Dynamics (CFD) during the design process of the wheel and fan to ensure the units would perform at the most efficient levels possible
- Improved cooling vanes on the wheel to promote better cooling capability which maximizes the life of the motor and drive components
- Commonized parts across the line, which adds up to cost savings and lower cost units for the customer
- New dome shaped top allowing for a single pass in the spinning process, reducing cost when manufacturing
- Curb cap sizes designed to match the competition for easy replacement of our competitor's fans. No need to replace the existing roof curb or purchase a curb-cap adaptor, which increases the overall cost of the unit

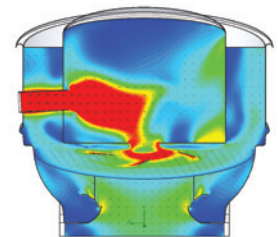
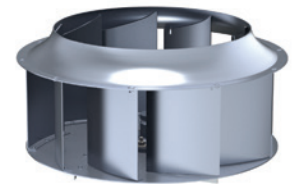

The Strongest Fans Are Now STRONGER

- Stress points are more evenly distributed throughout the fan base, providing for more stability during shipping and reducing vibration when the fan is operating
- The fan base is separated from the motor compartment with improved vibration isolators to reduce vibration and noise between the drive system and fan base
- Bead added to the fan shroud for more strength
- Increased motor compartment base strength Added bead to the dome shaped top to increase strength and allow for single point latches to reduce material



A Robust Product That Is Easier to Service

- Easy to remove motor compartments for accessing and servicing the wheel
- Motor mounting location moved to allow for better motor fit and easier adjustment in the field

* When comparing the new models to specific operating points of S&P's models DB, TXB, RED and TXD

Centrifugal Spun Aluminum Line Overview

We designed these fans so you can use smaller models and motors to meet the performance needed. With our new centrifugal spun aluminum line we are able to deliver wider performance ranges and unit sizes. The charts below show sample comparisons of the SDB and STXB vs. common competitors and the old DB and TXBs. These charts show at the most common static pressure points of these models (.25 to 1") the new SDB and STXB have more CFM/BHP. This means you can:

- Save \$ by using less energy to meet the same performance as the competitor.
- Save \$ by choosing the smallest motor to get the job done.

16" Downblast Belt Drive Performance Comparison

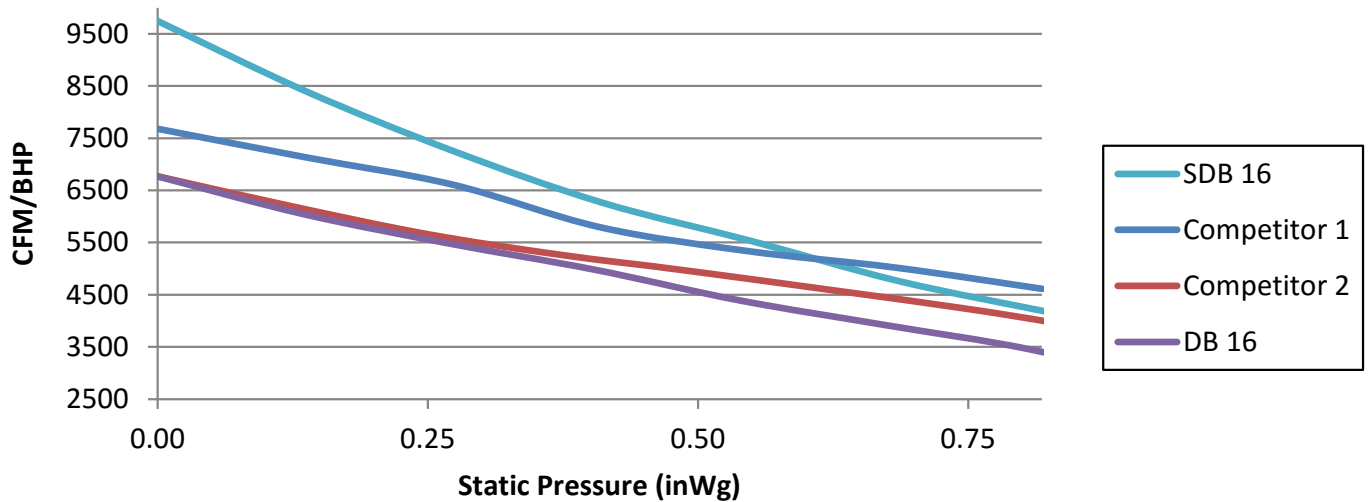

16" Upblast Belt Drive Performance Comparison

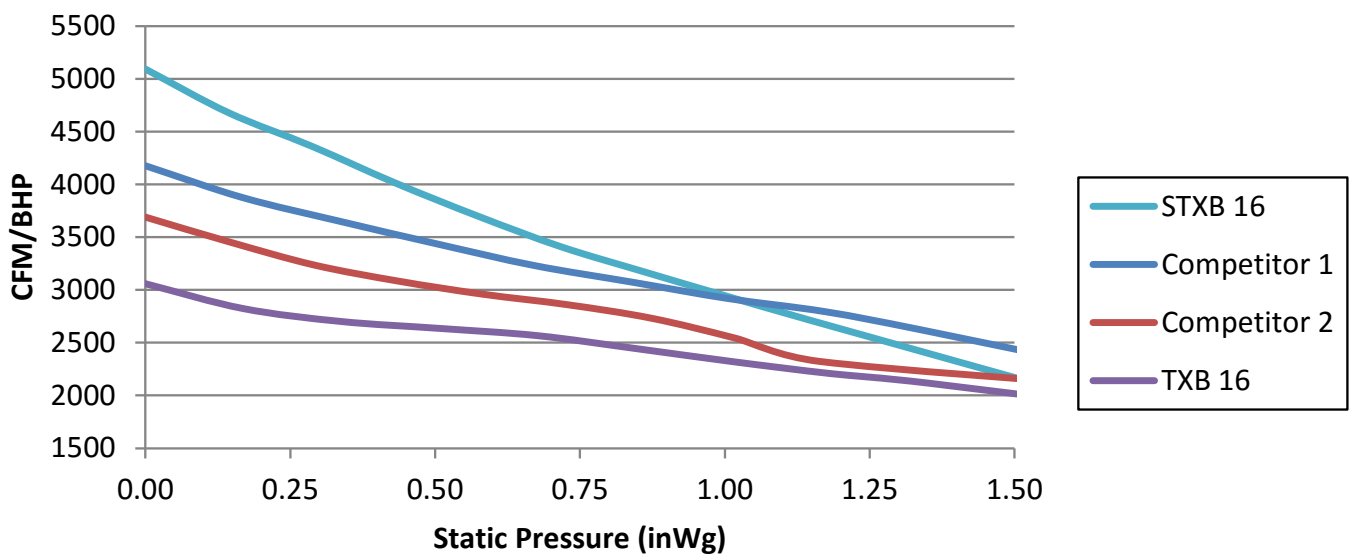



Downblast Model Overview & Construction Features

Model SDB - Belt Drive

Size Range	6, 7, 8, 10, 12, 14, 15 & 16
Motor HP Range	1/4 to 1
CFM Range	40 to 4135
Static Pressure	up to 1-1/2 in. w.g.
Warranty	5 years

Model SDBD & SDBDe* - Direct Drive

Size Range	6, 7, 8, 10, 12, 14, 15 & 16
Motor HP Range	1/25 to 1-1/2
CFM Range	40 to 4980
Static Pressure	up to 1-3/4 in. w.g.
Warranty	5 years

*Models SDBDe have Electronically Commutated (EC) Motors

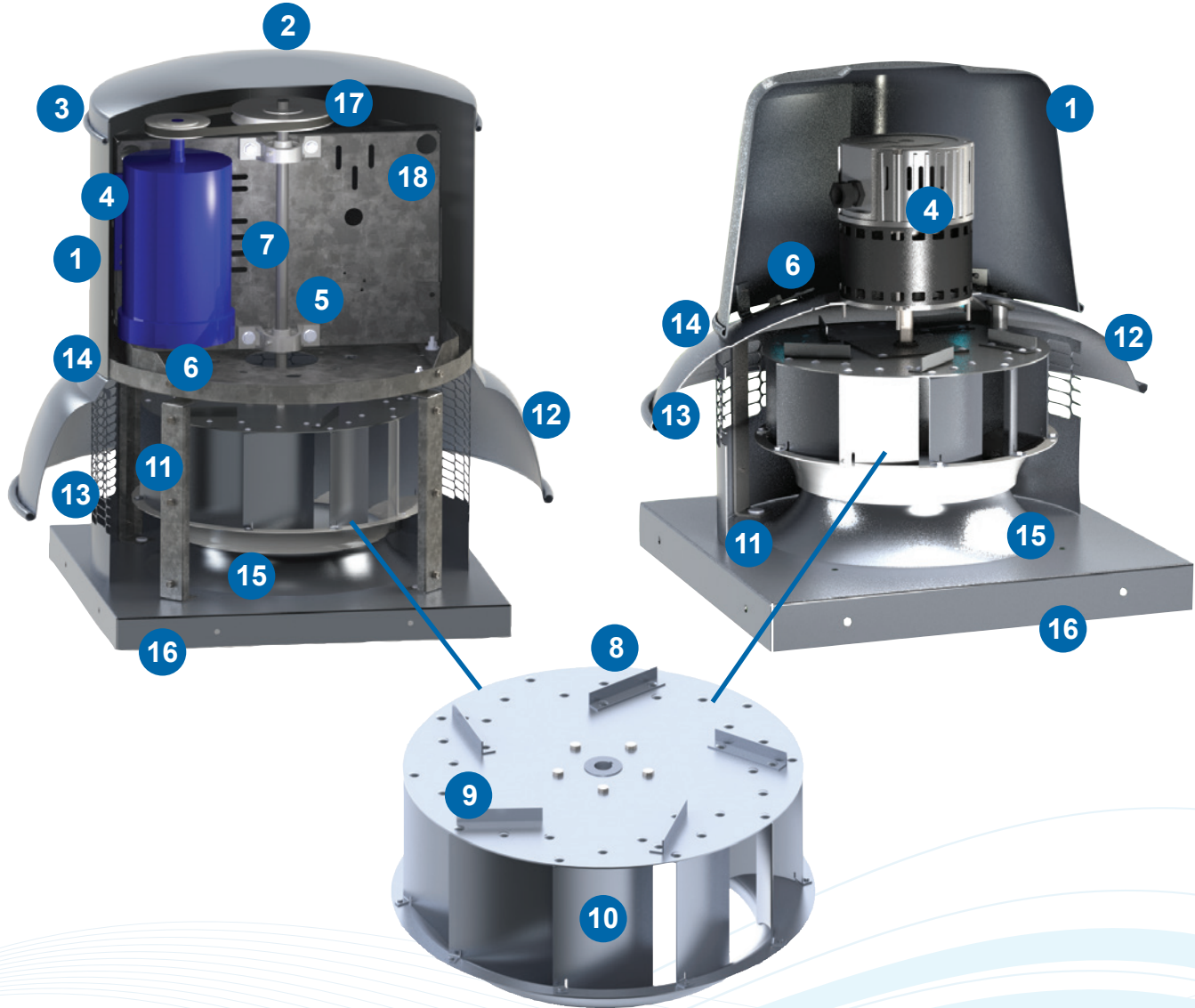

Applications

General Purpose Exhaust - Clean Air

- Bathrooms
- Garages
- General (non-grease) Kitchen Areas
- Offices
- Dormitories
- Manufacturing and Assembly plants
- Warehouse
- Places of Worship
- Schools
- Many More



Downblast Model Overview & Construction Features

#	Feature	Description
1	Motor Cover	Heavy-gauge aluminum motor cover provides weather protection for motor compartment.
2	Motor Cover Cap	Heavy-gauge aluminum top with rolled bead for added strength and quick-release latches.
3	Quick-Release Latches	Stainless steel latches for easy removal of motor cover cap for access to the motor compartment and motor.
4	Motor	Open drip-proof enclosure standard, many other options available. Model SDBDe comes standard with Electronically Commutated (EC) motors. See page 47 for additional EC motor information.
5	Bearings	Air handling ball bearing type with cast iron housing and grease fittings.
6	Vibration Isolators	Neoprene (rubber) vibration isolators to reduce vibration and noise.
7	Motor Mounting Plate	Heavy-gauge galvanized motor mounting plate.
8	Wheel	Aluminum, non-overloading, backward-inclined curved centrifugal wheel for maximum efficiency. Each wheel is dynamically balanced for smooth operation and long life.
9	Cooling Vanes	Helps promote cooling of the motor and drive by pulling air through the motor compartment. Helps maximize the life of the motor and drives.
10	Curved Blades	Designed to provide more CFM per HP and lower sound levels.
11	Support Legs	4 heavy-gauge galvanized support legs to anchor the motor plate to the fan base for stability and vibration reduction.
12	Fan Skirt	Aluminum fan skirt with rolled bead for extra strength. Fan skirt directs the exhausted air downward.
13	Birdscreen	Aluminum birdscreen standard to protect the fan from birds and other large objects.
14	Exterior Fasteners	Stainless steel.
15	Inlet Venturi	Deep spun single piece inlet venturi for optimum air and sound performance
16	Curb Cap	Fully welded curb cap for rigidity and weather protection. Pre-punched mounting holes for ease of installation.
17	Drives	Sized for 150% of drive HP, adjustable pitch motor sheaves.
18	Lifting Lugs	Standard on all belt drive models, SDB, for easy and safe placement of the fan on roof.
19	Disconnect Switch (not shown)	Standard with ODP and TE single speed motors. Ships loose.



DIMENSIONS

Dimensions in Inches

Model SDBD & SDBDe: Direct Drive Centrifugal Downblast

SDBD Sizes 6, 7, 8, & 10

SDBD Sizes 12, 14, 15, & 16

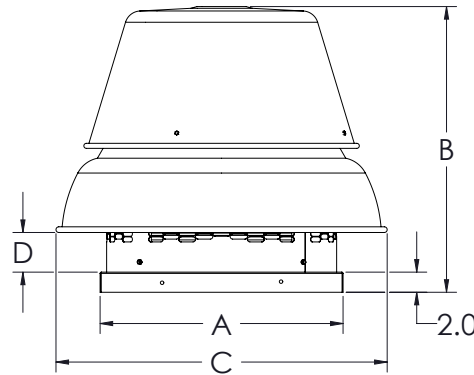
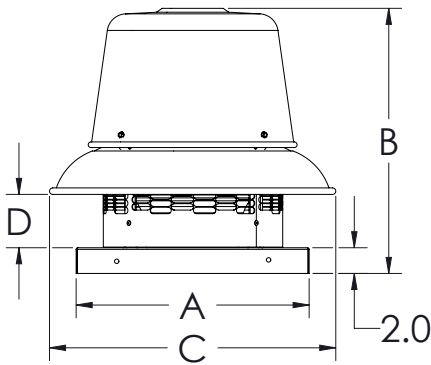

Size	A	B	C	D	Roof Opening	Curb O.D.	Damper O.D.	Average Ship Wt. Lbs.
6	18	14 1/8	22 1/4	1 1/2	13 1/2	16 1/2	12	109
7	18 1/8	20 5/8	22 1/4	4 1/8	13 1/2	16 1/2	12	109
8	18 1/8	20 5/8	22 1/4	4 1/8	13 1/2	16 1/2	12	109
10	18 1/8	20 5/8	22 1/4	4 1/8	13 1/2	16 1/2	12	109
12	20 1/8	27 11/16	27 9/16	3 5/8	15 1/2	18 1/2	14	122
14	20 1/8	27 11/16	27 9/16	3 5/8	15 1/2	18 1/2	14	126
15	24 1/8	28 3/8	32 7/8	3 15/16	19 1/2	22 1/2	18	140
16	24 1/8	28 3/8	32 7/8	3 15/16	19 1/2	22 1/2	18	140

Model SDB: Belt Drive Centrifugal Downblast

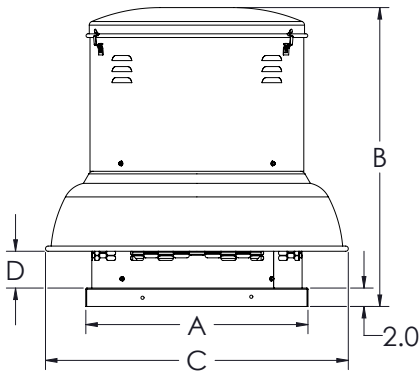

Size	A	B	C	D	Roof Opening	Curb O.D.	Damper (O.D.)	Average Ship Wt. Lbs.
6	18 1/8	30 1/16	25	3 3/8	13 1/2	16 1/2	12	109
7	18 1/8	30 1/16	25	3 3/8	13 1/2	16 1/2	12	109
8	18 1/8	30 1/16	25	3 3/8	13 1/2	16 1/2	12	109
10	18 1/8	30 1/16	25	3 3/8	13 1/2	16 1/2	12	109
12	20 1/8	31 11/16	27 9/16	3 7/8	15 1/2	18 1/2	14	122
14	20 1/8	31 11/16	27 9/16	3 7/8	15 1/2	18 1/2	14	126
15	24 1/8	32 7/16	32 7/8	4	19 1/2	22 1/2	18	140
16	24 1/8	32 7/16	32 7/8	4	19 1/2	22 1/2	18	140



OPTIONS/ACCESSORIES

Solid State Speed Control (SDBD): S&P's solid state control is matched to the motor and blower wheel to allow continuous reduction in performance allowing adjustments of airflow for system balancing. CFM is reduced in direct proportion to motor speed reduction. Speed control is available for 115 or 230 volt single phase. Exhauster performance can be controlled from the ventilated area.



Constant Pressure Controls (SDBDe): For constant pressure control applications, the S&P constant pressure control package is available. This package includes the components that are needed to complete a demand-based exhaust ventilation system for kitchens, bathrooms, and/or clothes dryer exhaust in multi-story buildings. S&P recognized that the programming procedure for many constant pressure controls can be challenging, so this package is the simplest system available. The control box can be easily installed in the field, either mounted on a curb or inside the building. The backlit LCD display and pressure transducer are pre-programmed to work together to increase or reduce the speed of the fan to accommodate for the actual demand.

Potentiometer Shipped Loose (SDBDe): If a variable rate that is manually changed by the operator from the occupied space is desired, the potentiometer is shipped loose and field installed in the appropriate accessible location. Simply rotating the dial will vary the speed of the fan from 20% to 100% full speed.

Automatic Belt Tensioner (SDB): Available on sizes 6-16, The Automatic Belt Tensioners eliminate the need for regular manual retensioning of drives, and the risk of inadvertently over-tensioning drive components is avoided and overall drive operating efficiency is enhanced. Benefits include reduction in startup and maintenance costs, increased belt life, increased drive efficiency, and ensure drive components do not snag obstructions.

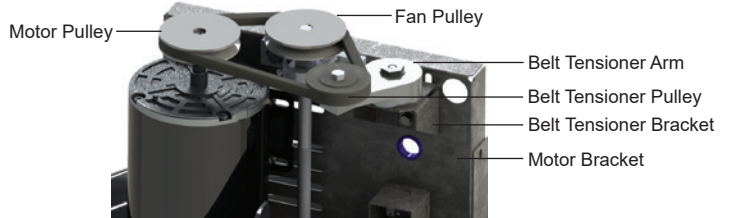

Roof Curb: Prefabricated heavy-gauge galvanized steel, welded construction, 12" high (other heights are also available) with 1-1/2" wood nailer. Assures perfect fit of exhauster to roof opening. Options include burglar bars, single or double pitch construction and hinged curbs for easy duct access.

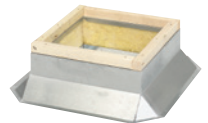

Sound Curb: Option of thermal acoustical lining or a complete maximum sound attenuating baffle system. Provision for mounting damper is available. Contact factory for information regarding effect on exhauster air performance and sound level.

Motor Operated Damper: Motor operated aluminum damper for positive closure against backdraft.

Automatic Damper: Automatic aluminum damper for ease in installation and effective backdraft protection.



Companion Gravity Units: Model RCX-II comes in a wide range of sizes and air capacities to provide relief or intake air to the system. Curbs and dampers are available to fit all sizes. Spun aluminum hoods provide a pleasing appearance, complementing the Model SDBD & SDB exhausters.

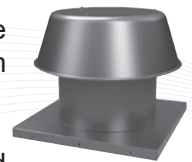

Special Coatings: Powered roof exhausters often require special coatings for protective and decorative purposes. Available coatings include: Synthetic Resin, Epoxy, and Heresite (air-dried phenolic). Contact your representative or the factory for more information on available coatings and colors.

Curb Hinge Arrangement: The curb hinge arrangement provides easy access to the exhaust fan, backdraft damper, and duct for servicing and cleaning.



CONSTRUCTION/SPECIFICATION CHECKLIST

Housing

- Curb cap has integral deep spun inlet for efficient performance and prepunched mounting holes for ease of installation.
- Spun aluminum hood and skirt for weather protection and attractive appearance.
- Heavy-gauge motor support for rigidity and strength.
- Neoprene isolators for reduction of vibration and sound.
- Conduit passage for easy electrical connection from below roof.
- Aluminum birdscreen is standard.
- Stainless steel fasteners on exterior.

Centrifugal Wheel

- All aluminum wheel.
- Backward-inclined for efficiency at higher static pressure.
- Non-overloading for safe operation in ducted systems.
- Curved blades for efficiency and quiet operation.
- Dynamically balanced for smooth operation.

Speed Controllable Motors

- Brands are nationally recognized and locally serviced.
- Motors are single speed, speed controllable and drip-proof.
- All motors are rated for continuous duty.
- Disconnect is standard.
- Motors ship mounted as standard.

Electronically Commutated Motors (SDBDe)

- Brands are nationally recognized and locally serviced.
- Easy speed control by DC 0-10 V variation.
- Motor has motor mounted potentiometer with digital readout for easy speed adjustment.
- Can be controlled by a PC or building management system.
- Motor has 80% usable turndown vs. 30% on a PSC motor.
- Internal motor circuitry converts 115/230 V single phase AC power to DC voltage for increased efficiencies.
- All motors are rated for continuous duty.
- Motor is 115/230V and 50/60 Hz.
- Disconnect is standard.
- Motors ship mounted as standard.

AMCA Seal

- Assures rating of Air and Sound performance.

UL Label

- UL 705 Listing assures electrical reliability.
- UL 705 must be specified when required.



PERFORMANCE

Sizes 6 & 7

Motor HP		RPM		Static Pressure in Inches w.g.							
				0	0.125	0.25	0.375	0.5	0.625	0.75	
SDBD6C 1/10 HP 1550 RPM	SDBDe6C 1/3 HP 1750 RPM	900	CFM	99	53	-	-	-	-	-	-
			BHP	0.01	0.01	-	-	-	-	-	-
			Sones	2.2	1.8	-	-	-	-	-	-
		1050	CFM	116	78	-	-	-	-	-	-
			BHP	0.02	0.02	-	-	-	-	-	-
			Sones	3.3	2.8	-	-	-	-	-	-
		1200	CFM	133	97	60	-	-	-	-	-
			BHP	0.02	0.03	0.03	-	-	-	-	-
			Sones	4.5	4.1	4.1	-	-	-	-	-
	1350	CFM	149	116	88	-	-	-	-	-	
		BHP	0.03	0.04	0.04	-	-	-	-	-	
		Sones	5.6	5.1	5	-	-	-	-	-	
	1500	CFM	166	134	111	80	-	-	-	-	
		BHP	0.05	0.05	0.05	0.05	-	-	-	-	
		Sones	6.5	6	5.9	5.9	-	-	-	-	
	1650	CFM	182	153	131	107	71	-	-	-	
		BHP	0.06	0.07	0.07	0.07	0.07	-	-	-	
		Sones	7.4	7	6.9	6.8	6.9	-	-	-	
	SDBD6 1/10 HP 1550 RPM	SDBDe6 1/3 HP 1750 RPM	900	CFM	192	91	-	-	-	-	-
				BHP	0.01	0.01	-	-	-	-	-
				Sones	1.9	1.5	-	-	-	-	-
1050			CFM	224	140	-	-	-	-	-	
			BHP	0.01	0.01	-	-	-	-	-	
			Sones	2.9	2.6	-	-	-	-	-	
1200			CFM	256	183	97	-	-	-	-	
			BHP	0.02	0.02	0.02	-	-	-	-	
			Sones	4	3.7	3.5	-	-	-	-	
1350		CFM	288	224	156	-	-	-	-		
		BHP	0.02	0.02	0.02	-	-	-	-		
		Sones	5	4.7	4.5	-	-	-	-		
1500		CFM	319	262	202	133	-	-	-		
		BHP	0.03	0.03	0.03	0.03	-	-	-		
		Sones	5.9	5.6	5.4	5.3	-	-	-		
1650		CFM	351	300	245	190	114	-	-		
		BHP	0.04	0.04	0.04	0.04	0.05	-	-		
		Sones	6.8	6.5	6.4	6.3	6.2	-	-		
SDBD7 1/10 HP 1550 RPM		SDBDe7 1/3 HP 1750 RPM	900	CFM	259	168	-	-	-	-	-
				BHP	0.01	0.02	-	-	-	-	-
				Sones	2.10	1.90	-	-	-	-	-
	1050		CFM	303	227	129	-	-	-	-	
			BHP	0.02	0.02	0.02	-	-	-	-	
			Sones	3.10	2.70	3.00	-	-	-	-	
	1200		CFM	346	281	204	97	-	-	-	
			BHP	0.03	0.03	0.04	0.04	-	-	-	
			Sones	4.40	3.80	3.90	4.20	-	-	-	
	1350	CFM	389	332	269	192	79	-	-		
		BHP	0.04	0.05	0.05	0.05	0.05	-	-		
		Sones	5.50	5.00	5.00	5.20	5.50	-	-		
	1500	CFM	432	382	326	264	191	79	-		
		BHP	0.06	0.06	0.07	0.07	0.07	0.07	-		
		Sones	6.40	6.20	6.20	6.30	6.50	6.70	-		
	1650	CFM	476	429	380	329	266	199	94		
		BHP	0.08	0.08	0.09	0.09	0.09	0.09	0.09		
		Sones	7.30	7.20	7.10	7.20	7.30	7.50	7.70		



S&P USA Ventilation Systems, LLC., Div. of Soler & Palau Ventilation Group, certifies that the Models SDBD shown herein are licensed to bear the AMCA Seal. The ratings shown are based on test and procedures performed in accordance with AMCA Publication 211 and AMCA Publication 311 and comply with the requirement of the AMCA Certified Ratings Program.



(1) Models SDBD6/SDBDe6 and SDBD6C/SDBDe6C have a choke plate. Performance certified is for installation type A-free inlet, free outlet. Performance ratings include the effects of birdscreen in the airstream.

The sound ratings shown are loudness values in fan sones @ 5' (1.5m) in a hemispherical free field calculated per AMCA Standard 301. Values shown are for Installation Type A: free inlet hemispherical sone levels.

Speed (RPM) shown is nominal. Performance is based on actual speed of test.

Fan RPM performances may vary from actual current motor offerings for any given model. See Optimizer2 fan selection software for current motor RPM offerings



Size 8

Motor HP	RPM		Static Pressure in Inches w.g.								
			0	0.125	0.25	0.375	0.5	0.625	0.75	0.875	
SDBD 1/25 HP 1050 RPM	700	CFM	361	187	-	-	-	-	-	-	-
		BHP	0.01	0.01	-	-	-	-	-	-	-
		Sones	2.3	1.5	-	-	-	-	-	-	-
	850	CFM	438	325	-	-	-	-	-	-	-
		BHP	0.01	0.01	-	-	-	-	-	-	-
		Sones	3.5	2.9	-	-	-	-	-	-	-
	1000	CFM	515	424	279	-	-	-	-	-	-
		BHP	0.02	0.02	0.02	-	-	-	-	-	-
		Sones	5	4.8	3.8	-	-	-	-	-	-
	1150	CFM	592	514	421	206	-	-	-	-	-
		BHP	0.03	0.03	0.03	0.03	-	-	-	-	-
		Sones	6.7	6.5	5.6	5	-	-	-	-	-
SDBD 1/10 HP 1550 RPM	1200	CFM	627	538	432	288	-	-	-	-	
		BHP	0.01	0.02	0.03	0.03	-	-	-	-	
		Sones	6	5.6	5.4	5	-	-	-	-	
	1250	CFM	653	568	470	348	-	-	-	-	
		BHP	0.01	0.02	0.03	0.04	-	-	-	-	
		Sones	6.5	6.1	5.9	5.5	-	-	-	-	
	1300	CFM	679	598	507	396	-	-	-	-	
		BHP	0.01	0.03	0.04	0.04	-	-	-	-	
		Sones	7.1	6.6	6.4	6.1	-	-	-	-	
	1350	CFM	705	627	543	437	284	-	-	-	
		BHP	0.02	0.03	0.04	0.04	0.04	-	-	-	
		Sones	7.6	7.1	6.9	6.6	6.3	-	-	-	
1400	CFM	731	657	576	476	351	-	-	-		
	BHP	0.02	0.03	0.04	0.05	0.05	-	-	-		
	Sones	8.2	7.7	7.4	7.2	6.8	-	-	-		
1450	CFM	757	687	609	514	409	-	-	-		
	BHP	0.02	0.04	0.05	0.05	0.06	-	-	-		
	Sones	8.8	8.3	7.9	7.8	7.4	-	-	-		
1500	CFM	783	716	640	552	456	304	-	-		
	BHP	0.02	0.04	0.05	0.06	0.06	0.05	-	-		
	Sones	9.5	8.9	8.5	8.4	8	7.7	-	-		
1550	CFM	809	746	672	589	497	373	-	-		
	BHP	0.03	0.04	0.05	0.06	0.07	0.07	-	-		
	Sones	10	9.3	8.9	8.9	8.5	8.2	-	-		
1600	CFM	835	775	702	626	537	434	265	-		
	BHP	0.03	0.04	0.05	0.07	0.07	0.08	0.06	-		
	Sones	10.4	9.8	9.3	9.3	9	8.7	8.4	-		
1650	CFM	862	804	733	662	576	485	343	-		
	BHP	0.03	0.05	0.06	0.08	0.08	0.08	0.07	-		
	Sones	10.9	10.3	9.7	9.7	9.5	9.2	8.9	-		
SDBD 1/4 HP 1625 RPM	1700	CFM	867	814	761	705	630	557	441	-	
		BHP	0.07	0.08	0.09	0.1	0.11	0.11	0.11	-	
		Sones	11	10.8	10.5	10.3	10	9.9	9.9	-	
	1750	CFM	892	842	789	738	667	595	505	297	
		BHP	0.08	0.09	0.1	0.11	0.12	0.12	0.12	0.1	
		Sones	11.5	11.3	11.1	10.8	10.6	10.4	10.4	11	

SDBDe
1/3 HP
1750 RPM



S&P USA Ventilation Systems, LLC., Div. of Soler & Palau Ventilation Group, certifies that the Models SDBD shown herein are licensed to bear the AMCA Seal. The ratings shown are based on test and procedures performed in accordance with AMCA Publication 211 and AMCA Publication 311 and comply with the requirement of the AMCA Certified Ratings Program.



Performance certified is for installation type A-free inlet, free outlet. Performance ratings include the effects of birdscreen in the airstream.

The sound ratings shown are loudness values in fan sones @ 5' (1.5m) in a hemispherical free field calculated per AMCA Standard 301. Values shown are for Installation Type A: free inlet hemispherical sone levels.

Speed (RPM) shown is nominal. Performance is based on actual speed of test.

Fan RPM performances may vary from actual current motor offerings for any given model. See Optisizer2 fan selection software for current motor RPM offerings



Size 10

Motor HP	RPM		Static Pressure in Inches w.g.										
			0	0.125	0.25	0.375	0.5	0.625	0.75	0.875	1		
SDBD 1/4 HP 1075 RPM	700	CFM	578	398	-	-	-	-	-	-	-	-	-
		BHP	0.01	0.02	-	-	-	-	-	-	-	-	-
		Sones	3.4	2.4	-	-	-	-	-	-	-	-	-
	850	CFM	701	559	-	-	-	-	-	-	-	-	-
		BHP	0.02	0.03	-	-	-	-	-	-	-	-	-
		Sones	5	4	-	-	-	-	-	-	-	-	-
	1000	CFM	825	705	575	-	-	-	-	-	-	-	-
		BHP	0.04	0.05	0.06	-	-	-	-	-	-	-	-
		Sones	6.7	5.7	5.4	-	-	-	-	-	-	-	-
	1150	CFM	949	847	738	607	419	-	-	-	-	-	-
		BHP	0.06	0.08	0.08	0.09	0.09	-	-	-	-	-	-
		Sones	8.6	7.6	7.1	7.1	7.1	-	-	-	-	-	-
	1200	CFM	951	857	748	624	458	-	-	-	-	-	-
		BHP	0.07	0.08	0.08	0.09	0.09	-	-	-	-	-	-
		Sones	7.3	6.8	5.9	5.1	5.2	-	-	-	-	-	-
1250	CFM	991	900	796	682	541	-	-	-	-	-	-	
	BHP	0.08	0.08	0.09	0.09	0.1	-	-	-	-	-	-	
	Sones	7.9	7.4	6.6	5.5	5.6	-	-	-	-	-	-	
1300	CFM	1031	944	844	739	613	424	-	-	-	-	-	
	BHP	0.09	0.09	0.1	0.1	0.11	0.11	-	-	-	-	-	
	Sones	8.5	8	7.4	6	6	6.2	-	-	-	-	-	
1350	CFM	1070	987	892	793	677	527	-	-	-	-	-	
	BHP	0.1	0.1	0.11	0.12	0.12	0.12	-	-	-	-	-	
	Sones	9.1	8.6	8.1	6.7	6.4	6.5	-	-	-	-	-	
1400	CFM	1110	1030	939	846	738	609	402	-	-	-	-	
	BHP	0.11	0.12	0.12	0.13	0.13	0.14	0.13	-	-	-	-	
	Sones	9.7	9.2	8.8	7.5	6.8	6.9	7.1	-	-	-	-	
1450	CFM	1150	1072	986	896	796	680	522	-	-	-	-	
	BHP	0.12	0.13	0.14	0.14	0.15	0.15	0.15	-	-	-	-	
	Sones	10.3	9.8	9.4	8.2	7.2	7.3	7.5	-	-	-	-	
1500	CFM	1189	1115	1033	946	852	745	614	398	-	-	-	
	BHP	0.13	0.14	0.15	0.15	0.16	0.17	0.17	0.16	-	-	-	
	Sones	11	10.5	10.1	9.1	7.8	7.8	7.9	8.1	-	-	-	
1550	CFM	1229	1157	1079	994	906	806	691	529	-	-	-	
	BHP	0.15	0.16	0.16	0.17	0.17	0.18	0.19	0.18	-	-	-	
	Sones	11.5	11	10.6	9.8	8.4	8	8.2	8.4	-	-	-	
1600	CFM	1269	1199	1125	1042	959	865	761	628	414	-	-	
	BHP	0.16	0.17	0.18	0.18	0.19	0.2	0.2	0.2	0.19	-	-	
	Sones	12	11.6	11.1	10.5	9.1	8.3	8.4	8.7	8.9	-	-	
1650	CFM	1308	1241	1170	1089	1011	922	824	710	550	-	-	
	BHP	0.18	0.19	0.2	0.2	0.21	0.22	0.22	0.22	0.22	-	-	
	Sones	12.6	12.1	11.7	11.2	9.8	8.6	8.8	9	9.1	-	-	
1700	CFM	1348	1282	1214	1137	1060	977	886	783	653	-	-	
	BHP	0.19	0.2	0.21	0.22	0.22	0.23	0.24	0.24	0.24	-	-	
	Sones	13.1	12.6	12.2	11.8	10.5	9.3	9.1	9.2	9.4	-	-	

SDBDe
1/3 HP
1750 RPM

SDBD
1/3 HP
1625 RPM

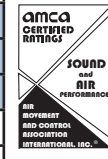

S&P USA Ventilation Systems, LLC., Div. of Soler & Palau Ventilation Group, certifies that the Models SDBD shown herein are licensed to bear the AMCA Seal. The ratings shown are based on test and procedures performed in accordance with AMCA Publication 211 and AMCA Publication 311 and comply with the requirement of the AMCA Certified Ratings Program.



Performance certified is for installation type A-free inlet, free outlet. Performance ratings include the effects of birdscreen in the airstream.

The sound ratings shown are loudness values in fan sones @ 5' (1.5m) in a hemispherical free field calculated per AMCA Standard 301. Values shown are for Installation Type A: free inlet hemispherical sone levels.

Speed (RPM) shown is nominal. Performance is based on actual speed of test.

Fan RPM performances may vary from actual current motor offerings for any given model. See Optimizer2 fan selection software for current motor RPM offerings



Size 12

Motor HP	RPM	Static Pressure in Inches w.g.											
		0	0.125	0.25	0.375	0.5	0.625	0.75	0.875	1	1.25		
SDBD 1/4 HP 1075 RPM	900	CFM	1000	856	673	-	-	-	-	-	-	-	-
		BHP	0.06	0.07	0.07	-	-	-	-	-	-	-	-
		Sones	6.0	5.4	4.9	-	-	-	-	-	-	-	-
	950	CFM	1055	920	756	479	-	-	-	-	-	-	-
		BHP	0.07	0.08	0.09	0.09	-	-	-	-	-	-	-
		Sones	6.6	6.0	5.5	5.3	-	-	-	-	-	-	-
	1000	CFM	1111	984	830	626	-	-	-	-	-	-	-
		BHP	0.08	0.09	0.10	0.10	-	-	-	-	-	-	-
		Sones	7.2	6.6	6.1	5.9	-	-	-	-	-	-	-
	1050	CFM	1167	1047	902	728	-	-	-	-	-	-	-
		BHP	0.10	0.11	0.11	0.12	-	-	-	-	-	-	-
		Sones	7.8	7.2	6.7	6.4	-	-	-	-	-	-	-
	1100	CFM	1222	1110	975	821	564	-	-	-	-	-	-
		BHP	0.11	0.12	0.13	0.13	0.13	-	-	-	-	-	-
		Sones	8.4	7.9	7.3	7.0	6.9	-	-	-	-	-	-
	1150	CFM	1281	1176	1050	909	719	-	-	-	-	-	-
		BHP	0.13	0.14	0.15	0.15	0.16	-	-	-	-	-	-
		Sones	9.1	8.5	8.0	7.5	7.5	-	-	-	-	-	-
	SDBD 1/2 HP 1625 RPM	1200	CFM	1331	1101	1108	971	805	524	-	-	-	-
			BHP	0.10	0.13	0.13	0.14	0.14	0.14	-	-	-	-
			Sones	9.0	8.6	8.3	8.0	8.0	8.0	-	-	-	-
1250		CFM	1386	1124	1175	1047	897	702	-	-	-	-	
		BHP	0.11	0.15	0.15	0.15	0.16	0.16	-	-	-	-	
		Sones	9.6	9.2	8.9	8.6	8.5	8.6	-	-	-	-	
1300		CFM	1442	1151	1240	1121	983	822	514	-	-	-	
		BHP	0.13	0.17	0.16	0.17	0.18	0.18	0.17	-	-	-	
		Sones	10.3	9.9	9.6	9.3	9.0	9.1	9.2	-	-	-	
1350		CFM	1497	1182	1304	1193	1065	916	707	-	-	-	
		BHP	0.14	0.19	0.18	0.19	0.20	0.20	0.20	-	-	-	
		Sones	10.9	10.5	10.2	10.0	9.6	9.7	9.8	-	-	-	
1400		CFM	1553	1215	1366	1263	1143	1007	850	539	-	-	
		BHP	0.16	0.21	0.20	0.21	0.22	0.23	0.23	0.21	-	-	
		Sones	11.6	11.2	10.9	10.6	10.3	10.3	10.4	10.5	-	-	
1450		CFM	1608	1252	1428	1331	1219	1093	949	735	-	-	
		BHP	0.18	0.24	0.22	0.23	0.24	0.25	0.25	0.25	-	-	
		Sones	12.3	11.9	11.6	11.3	11.0	10.8	10.9	11.1	-	-	
1500		CFM	1664	1291	1474	1398	1293	1175	1043	890	589	-	
		BHP	0.20	0.26	0.24	0.25	0.26	0.27	0.28	0.28	0.26	-	
		Sones	13.0	12.6	12.3	12.0	11.7	11.5	11.6	11.7	11.8	-	
1550	CFM	1719	1333	1495	1464	1365	1254	1132	995	785	-		
	BHP	0.22	0.29	0.27	0.28	0.29	0.30	0.31	0.31	0.30	-		
	Sones	13.7	13.3	12.9	12.7	12.4	12.1	12.1	12.2	12.3	-		
1600	CFM	1774	1377	1515	1529	1435	1331	1217	1089	942	-		
	BHP	0.24	0.32	0.30	0.30	0.31	0.32	0.33	0.34	0.34	-		
	Sones	14.4	14.0	13.6	13.3	13.0	12.8	12.6	12.7	12.8	-		
1650	CFM	1830	1424	1536	1592	1504	1406	1298	1180	1051	-		
	BHP	0.26	0.35	0.34	0.33	0.34	0.35	0.36	0.37	0.37	-		
	Sones	15.1	14.7	14.3	14.0	13.7	13.4	13.2	13.2	13.3	-		
1700	CFM	1902	1486	1565	1674	1592	1500	1401	1292	1173	811		
	BHP	0.29	0.39	0.38	0.36	0.38	0.39	0.40	0.41	0.41	0.41		
	Sones	15.9	15.4	15.0	14.7	14.4	14.1	13.8	13.7	13.9	14.1		

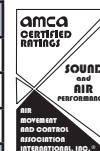

S&P USA Ventilation Systems, LLC., Div. of Soler & Palau Ventilation Group, certifies that the Models SDBD shown herein are licensed to bear the AMCA Seal. The ratings shown are based on test and procedures performed in accordance with AMCA Publication 211 and AMCA Publication 311 and comply with the requirement of the AMCA Certified Ratings Program.



Performance certified is for installation type A-free inlet, free outlet. Performance ratings include the effects of birdscreen in the airstream.

The sound ratings shown are loudness values in fan sones @ 5' (1.5m) in a hemispherical free field calculated per AMCA Standard 301. Values shown are for Installation Type A: free inlet hemispherical sone levels.

Speed (RPM) shown is nominal. Performance is based on actual speed of test.

Fan RPM performances may vary from actual current motor offerings for any given model. See Optimizer2 fan selection software for current motor RPM offerings



MODEL SDBD & SDBDe
DIRECT DRIVE CENTRIFUGAL DOWNBLAST ROOF EXHAUSTERS

Size 14

Motor HP	RPM	Static Pressure in Inches w.g.												
		0	0.125	0.25	0.375	0.5	0.625	0.75	0.875	1	1.25	1.5		
SDBD 1/4 HP 1075 RPM	750	CFM	1511	1269	942	-	-	-	-	-	-	-	-	-
		BHP	0.07	0.08	0.08	-	-	-	-	-	-	-	-	-
		Sones	6.5	5.7	4.6	-	-	-	-	-	-	-	-	-
	800	CFM	1612	1387	1103	-	-	-	-	-	-	-	-	-
		BHP	0.08	0.09	0.10	-	-	-	-	-	-	-	-	-
		Sones	7.3	6.5	5.3	-	-	-	-	-	-	-	-	-
	850	CFM	1712	1503	1252	892	-	-	-	-	-	-	-	-
		BHP	0.10	0.11	0.12	0.12	-	-	-	-	-	-	-	-
		Sones	8.2	7.4	6.2	5.7	-	-	-	-	-	-	-	-
	900	CFM	1813	1617	1393	1093	-	-	-	-	-	-	-	-
		BHP	0.12	0.13	0.14	0.15	-	-	-	-	-	-	-	-
		Sones	9.0	8.3	7.2	6.5	-	-	-	-	-	-	-	-
950	CFM	1914	1731	1524	1256	858	-	-	-	-	-	-	-	
	BHP	0.14	0.15	0.17	0.17	0.16	-	-	-	-	-	-	-	
	Sones	9.9	9.2	8.2	7.2	7.0	-	-	-	-	-	-	-	
1000	CFM	2015	1845	1649	1412	1116	-	-	-	-	-	-	-	
	BHP	0.16	0.18	0.19	0.20	0.20	-	-	-	-	-	-	-	
	Sones	11.0	10.2	9.4	8.0	7.8	-	-	-	-	-	-	-	
1050	CFM	2115	1958	1769	1560	1298	884	-	-	-	-	-	-	
	BHP	0.18	0.20	0.22	0.23	0.23	0.22	-	-	-	-	-	-	
	Sones	12.0	11.3	10.5	9.1	8.6	8.4	-	-	-	-	-	-	
1100	CFM	2196	2047	1864	1673	1428	1115	-	-	-	-	-	-	
	BHP	0.21	0.23	0.24	0.25	0.26	0.25	-	-	-	-	-	-	
	Sones	13.0	12.3	11.6	10.2	9.4	9.2	-	-	-	-	-	-	
SDBD 3/4 HP 1650 RPM	1,150	CFM	2285	2164	2042	1894	1732	1562	1306	-	-	-	-	
		BHP	0.25	0.28	0.31	0.33	0.36	0.37	0.37	-	-	-	-	
		Sones	12.2	11.6	11.2	10.7	10.2	9.7	10.4	-	-	-	-	
	1,200	CFM	2384	2268	2152	2018	1862	1708	1508	1207	-	-	-	
		BHP	0.28	0.31	0.34	0.37	0.40	0.42	0.43	0.40	-	-	-	
		Sones	13.1	12.5	12.1	11.7	11.2	10.6	10.8	11.7	-	-	-	
	1,250	CFM	2484	2372	2262	2138	1990	1842	1680	1437	-	-	-	
		BHP	0.32	0.35	0.38	0.41	0.44	0.46	0.48	0.47	-	-	-	
		Sones	13.8	13.3	13.0	12.7	12.2	11.6	11.1	12.0	-	-	-	
	1,300	CFM	2583	2476	2370	2255	2117	1974	1830	1643	1393	-	-	
		BHP	0.36	0.39	0.42	0.46	0.49	0.51	0.53	0.54	0.52	-	-	
		Sones	14.7	14.2	14.0	13.7	13.2	12.6	12.2	12.3	13.2	-	-	
1,350	CFM	2682	2579	2477	2369	2242	2104	1967	1814	1597	-	-		
	BHP	0.40	0.44	0.47	0.50	0.54	0.57	0.59	0.60	0.60	-	-		
	Sones	15.6	15.2	14.9	14.7	14.2	13.7	13.1	12.7	13.5	-	-		
1,400	CFM	2782	2682	2584	2482	2365	2231	2099	1965	1794	-	-		
	BHP	0.45	0.48	0.52	0.55	0.59	0.62	0.65	0.66	0.68	-	-		
	Sones	16.8	16.2	15.9	15.7	15.4	14.8	14.2	13.7	13.8	-	-		
1,450	CFM	2881	2785	2690	2593	2485	2358	2230	2103	1961	1540	-		
	BHP	0.50	0.53	0.57	0.61	0.64	0.68	0.71	0.73	0.75	0.72	-		
	Sones	17.9	17.3	17.0	16.7	16.5	15.9	15.4	14.9	14.3	16.0	-		
1,500	CFM	2980	2887	2796	2703	2601	2483	2358	2235	2110	1744	-		
	BHP	0.55	0.59	0.63	0.66	0.70	0.74	0.77	0.80	0.82	0.82	-		
	Sones	19.0	18.4	18.0	17.8	17.6	17.1	16.5	16.0	15.5	16.3	-		
1,550	CFM	3080	2990	2901	2812	2716	2607	2485	2367	2247	1950	-		
	BHP	0.61	0.65	0.69	0.72	0.76	0.80	0.84	0.87	0.89	0.92	-		
	Sones	20.2	19.6	19.0	18.7	18.4	18.0	17.5	16.9	16.4	16.4	-		
1,600	CFM	3179	3092	3006	2920	2829	2728	2612	2496	2380	2125	1744		
	BHP	0.67	0.71	0.75	0.79	0.83	0.87	0.91	0.94	0.97	1.01	0.98		
	Sones	21.4	20.8	20.2	19.6	19.4	19.2	18.6	18.0	17.5	16.7	18.4		
1,650	CFM	3278	3194	3110	3027	2940	2846	2737	2623	2512	2280	1941		
	BHP	0.73	0.78	0.82	0.86	0.90	0.94	0.98	1.02	1.05	1.09	1.10		
	Sones	22.6	21.9	21.3	20.8	20.3	20.1	19.5	19.0	18.4	17.4	18.5		
SDBD 1 HP 1725 RPM	1,725	CFM	3507	3432	3345	3245	3137	3025	2911	2802	2683	2401	2014	
		BHP	0.64	0.67	0.69	0.72	0.75	0.78	0.81	0.84	0.86	0.89	0.88	
		Sones	23.1	22.5	21.9	21.3	20.8	20.3	19.8	19.3	18.8	18.1	17.6	



S&P USA Ventilation Systems, LLC., Div. of Soler & Palau Ventilation Group, certifies that the Models SDBD shown herein are licensed to bear the AMCA Seal. The ratings shown are based on test and procedures performed in accordance with AMCA Publication 211 and AMCA Publication 311 and comply with the requirement of the AMCA Certified Ratings Program.



Performance certified is for installation type A-free inlet, free outlet. Performance ratings include the effects of birdscreen in the airstream.

The sound ratings shown are loudness values in fan sones @ 5' (1.5m) in a hemispherical free field calculated per AMCA Standard 301. Values shown are for Installation Type A: free inlet hemispherical sone levels.

Speed (RPM) shown is nominal. Performance is based on actual speed of test.

Fan RPM performances may vary from actual current motor offerings for any given model. See Optisizer2 fan selection software for current motor RPM offerings.

Numbers shown in **bold font** are only achievable by the SDBDe 1 HP model with EC motor.



MODEL SDBD & SDBDe
DIRECT DRIVE CENTRIFUGAL DOWNBLAST ROOF EXHAUSTERS

Size 15

Motor HP	RPM		Static Pressure in Inches w.g.													
			0	0.125	0.25	0.375	0.5	0.625	0.75	0.875	1	1.25	1.5	1.75		
SDBD 1/2 HP 1150 RPM	750	CFM	1748	1556	1282	779	-	-	-	-	-	-	-	-	-	-
		BHP	0.08	0.09	0.10	0.10	-	-	-	-	-	-	-	-	-	-
		Sones	7.4	6.9	6.2	5.6	-	-	-	-	-	-	-	-	-	-
	800	CFM	1865	1688	1445	1140	-	-	-	-	-	-	-	-	-	-
		BHP	0.10	0.11	0.12	0.13	-	-	-	-	-	-	-	-	-	-
		Sones	8.3	7.7	7.1	6.4	-	-	-	-	-	-	-	-	-	-
	850	CFM	1981	1816	1601	1334	-	-	-	-	-	-	-	-	-	-
		BHP	0.11	0.13	0.15	0.16	-	-	-	-	-	-	-	-	-	-
		Sones	9.2	8.6	8.2	7.3	-	-	-	-	-	-	-	-	-	-
	900	CFM	2098	1943	1751	1508	1199	-	-	-	-	-	-	-	-	-
		BHP	0.14	0.16	0.17	0.18	0.19	-	-	-	-	-	-	-	-	-
		Sones	10.1	9.5	9.3	8.3	7.8	-	-	-	-	-	-	-	-	-
	950	CFM	2214	2068	1896	1674	1419	-	-	-	-	-	-	-	-	-
		BHP	0.16	0.18	0.20	0.21	0.22	-	-	-	-	-	-	-	-	-
		Sones	11.1	10.5	10.3	9.5	8.6	-	-	-	-	-	-	-	-	-
	1000	CFM	2331	2192	2035	1833	1606	1301	-	-	-	-	-	-	-	-
		BHP	0.19	0.21	0.23	0.24	0.25	0.25	-	-	-	-	-	-	-	-
		Sones	12.2	11.5	11.3	10.7	9.8	9.4	-	-	-	-	-	-	-	-
	1050	CFM	2447	2315	2172	1988	1778	1537	-	-	-	-	-	-	-	-
		BHP	0.21	0.24	0.26	0.27	0.29	0.30	-	-	-	-	-	-	-	-
		Sones	13.2	12.6	12.3	11.9	11.0	10.2	-	-	-	-	-	-	-	-
	1100	CFM	2564	2438	2305	2138	1943	1732	1454	-	-	-	-	-	-	-
		BHP	0.25	0.27	0.29	0.31	0.33	0.34	0.34	-	-	-	-	-	-	-
		Sones	14.4	13.6	13.4	13.2	12.3	11.5	11.1	-	-	-	-	-	-	-
1150	CFM	2685	2565	2440	2289	2109	1913	1690	1260	-	-	-	-	-	-	
	BHP	0.28	0.31	0.33	0.35	0.37	0.38	0.39	0.38	-	-	-	-	-	-	
	Sones	15.6	14.8	14.6	14.4	13.6	12.7	12.0	12.0	-	-	-	-	-	-	
SDBD 3/4 HP 1650 RPM	1450	CFM	2774	2665	2547	2439	2321	2187	2058	1912	1757	1657	-	-	-	
		BHP	0.44	0.47	0.50	0.52	0.55	0.58	0.60	0.61	0.62	0.63	-	-	-	
		Sones	18.9	18.3	17.7	17.2	16.7	16.2	15.8	15.9	16.1	16.6	-	-	-	
	1500	CFM	2869	2764	2651	2545	2436	2307	2183	2050	1900	1700	-	-	-	
		BHP	0.49	0.52	0.55	0.57	0.60	0.63	0.65	0.67	0.68	0.69	-	-	-	
		Sones	20.1	19.4	18.8	18.2	17.7	17.3	16.9	16.8	17.0	17.4	-	-	-	
	1550	CFM	2965	2863	2754	2649	2549	2427	2304	2182	2044	1744	1517	-	-	
		BHP	0.54	0.57	0.60	0.63	0.66	0.69	0.71	0.73	0.75	0.77	0.76	-	-	
		Sones	21.0	20.4	19.8	19.2	18.6	18.1	17.7	17.4	17.5	17.9	18.4	-	-	
	1600	CFM	3061	2962	2857	2754	2657	2546	2424	-	-	-	-	-	-	
		BHP	0.59	0.63	0.66	0.68	0.72	0.75	0.77	-	-	-	-	-	-	
		Sones	21.9	21.3	20.8	20.2	19.7	19.2	18.7	-	-	-	-	-	-	
	1650	CFM	3156	3061	2960	2857	2765	-	-	-	-	-	-	-	-	
		BHP	0.65	0.68	0.72	0.74	0.78	-	-	-	-	-	-	-	-	
		Sones	22.8	22.2	21.7	21.1	20.6	-	-	-	-	-	-	-	-	
SDBD 1-1/2 HP 1725 RPM	1750	CFM	4083	4005	3920	3825	3723	3622	3523	3421	3308	3068	2810	2508		
		BHP	0.82	0.85	0.89	0.92	0.96	0.99	1.03	1.06	1.09	1.15	1.19	1.22		
		Sones	22.2	21.9	21.5	21.1	20.7	20.5	20.6	20.6	20.6	20.7	20.9	21.1		

Performance certified is for installation type A-free inlet, free outlet. Performance ratings include the effects of birdscreen in the airstream.

The sound ratings shown are loudness values in fan sones @ 5' (1.5m) in a hemispherical free field calculated per AMCA Standard 301. Values shown are for Installation Type A: free inlet hemispherical sone levels.

Speed (RPM) shown is nominal. Performance is based on actual speed of test.

Fan RPM performances may vary from actual current motor offerings for any given model. See Optimizer2 fan selection software for current motor RPM offerings

S&P USA: www.solerpalau-usa.com



S&P USA Ventilation Systems, LLC., Div. of Soler & Palau Ventilation Group, certifies that the Models SDBD shown herein are licensed to bear the AMCA Seal. The ratings shown are based on test and procedures performed in accordance with AMCA Publication 211 and AMCA Publication 311 and comply with the requirement of the AMCA Certified Ratings Program.



S&P Canada: www.solerpalaucanada.com



Size 16

Motor HP	RPM		Static Pressure in Inches w.g.												
			0	0.125	0.25	0.375	0.5	0.625	0.75	0.875	1	1.25	1.5	1.75	
SDBD 1/2 HP 1150	750	CFM	2172	1945	1680	1317	-	-	-	-	-	-	-	-	
		BHP	0.11	0.13	0.13	0.14	-	-	-	-	-	-	-	-	
		Sones	8.6	8.1	7.4	6.7	-	-	-	-	-	-	-	-	
	800	CFM	2316	2105	1864	1555	-	-	-	-	-	-	-	-	
		BHP	0.13	0.15	0.16	0.17	-	-	-	-	-	-	-	-	
		Sones	9.6	9.1	8.5	7.9	-	-	-	-	-	-	-	-	
	850	CFM	2461	2263	2039	1776	1424	-	-	-	-	-	-	-	
		BHP	0.16	0.18	0.19	0.20	0.20	-	-	-	-	-	-	-	
		Sones	10.6	10.1	9.6	9.1	8.3	-	-	-	-	-	-	-	
	900	CFM	2606	2419	2212	1984	1682	-	-	-	-	-	-	-	
		BHP	0.19	0.21	0.23	0.23	0.24	-	-	-	-	-	-	-	
		Sones	11.7	11.2	10.7	10.3	9.5	-	-	-	-	-	-	-	
	950	CFM	2751	2574	2383	2175	1913	1590	-	-	-	-	-	-	
		BHP	0.22	0.24	0.26	0.27	0.28	0.28	-	-	-	-	-	-	
		Sones	12.8	12.4	12.0	11.4	11.0	10.1	-	-	-	-	-	-	
	1000	CFM	2896	2727	2551	2354	2129	1849	-	-	-	-	-	-	
		BHP	0.25	0.28	0.30	0.32	0.33	0.33	-	-	-	-	-	-	
		Sones	13.9	13.5	13.2	12.7	12.3	11.5	-	-	-	-	-	-	
	1050	CFM	3040	2880	2716	2527	2334	2085	1802	-	-	-	-	-	
		BHP	0.29	0.32	0.34	0.36	0.37	0.38	0.38	-	-	-	-	-	
		Sones	15.1	14.7	14.4	14.0	13.6	13.1	12.1	-	-	-	-	-	
	1100	CFM	3185	3032	2877	2701	2523	2304	2048	-	-	-	-	-	
		BHP	0.34	0.36	0.39	0.41	0.42	0.44	0.44	-	-	-	-	-	
		Sones	16.4	16.0	15.7	15.3	14.9	14.6	13.7	-	-	-	-	-	
1150	CFM	3298	3150	3002	2835	2663	2468	2234	1975	-	-	-	-		
	BHP	0.37	0.40	0.43	0.45	0.47	0.48	0.49	0.49	-	-	-	-		
	Sones	17.7	17.3	17.0	16.6	16.3	15.9	15.4	14.3	-	-	-	-		
SDBD 1-1/2 HP 1725 RPM	1750	CFM	4984	4896	4804	4705	4601	4493	4383	4271	4155	3911	3636	3305	
		BHP	1.16	1.20	1.24	1.28	1.32	1.36	1.39	1.42	1.45	1.53	1.59	1.63	
		Sones	31.7	31.4	31.1	30.9	30.7	30.7	30.4	29.8	29.2	28.1	27.2	26.7	

Performance certified is for installation type A-free inlet, free outlet. Performance ratings include the effects of birdscreen in the airstream.

The sound ratings shown are loudness values in fan sones @ 5' (1.5m) in a hemispherical free field calculated per AMCA Standard 301. Values shown are for Installation Type A: free inlet hemispherical sone levels.

Speed (RPM) shown is nominal. Performance is based on actual speed of test.

Fan RPM performances may vary from actual current motor offerings for any given model. See Optimizer2 fan selection software for current motor RPM offerings



S&P USA Ventilation Systems, LLC., Div. of Soler & Palau Ventilation Group, certifies that the Models SDBD shown herein are licensed to bear the AMCA Seal. The ratings shown are based on test and procedures performed in accordance with AMCA Publication 211 and AMCA Publication 311 and comply with the requirement of the AMCA Certified Ratings Program.





CONSTRUCTION/SPECIFICATION CHECKLIST

Housing

- Curb cap has integral deep spun inlet for efficient performance and prepunched mounting holes for ease of installation.
- Lifting lugs for easy and safe placement of the fan on the roof.
- Spun aluminum hood and skirt for weather protection and attractive appearance.
- Heavy-gauge motor support for rigidity and strength.
- Neoprene isolators for reduction of vibration and sound.
- Quick-Release latches on motor cover for easy access to motor compartment.
- Conduit passage for easy electrical connection from below roof.
- Aluminum birdscreen is standard.
- Stainless steel fasteners on exterior.

Centrifugal Wheel

- All aluminum wheel.
- Backward-inclined for efficiency at higher static pressure.
- Non-overloading for safe operation in ducted systems.
- Curved blades for efficiency and quiet operation.
- Dynamically balanced for smooth operation.

Motors

- 1 year warranty.
- Brands are nationally recognized and locally serviced.
- Single speed open drip-proof are standard.
- Explosion-proof, totally enclosed and two-speed motors are available.
- All motors are rated for continuous duty.
- 182T and larger motors shipped unmounted for field installation.
- Disconnect switch standard on single speed drip-proof and totally enclosed motors.

Drives

- Sized for minimum 150% of drive horsepower.
- Machined cast iron adjustable motor pulleys.
- Adjustable base for belt tensioning.
- Non-static oil resistant V-Belts.

Bearings

- 5 year bearing warranty.
- Heavy-duty ball bearing type.
- Air handling with grease fittings.
- Sized for a minimum L50 life in excess of 200,000 hours.

AMCA Seal

- Assures accuracy of Air and Sound Performance.

cULus Label

- cULus 705 listing assures electrical safety and reliability.
- cULus 705 must be specified when required.



SIZE 6

Motor HP	RPM		Static Pressure in Inches w.g.							
			0	0.125	0.25	0.375	0.5	0.625	0.75	0.875
1/4	700	CFM	131	41	-	-	-	-	-	-
		BHP	0.01	0.01	-	-	-	-	-	-
		Sones	1.2	1.2	-	-	-	-	-	-
1/4	850	CFM	159	104	-	-	-	-	-	-
		BHP	0.01	0.02	-	-	-	-	-	-
		Sones	2.1	2.0	-	-	-	-	-	-
1/4	900	CFM	169	118	-	-	-	-	-	-
		BHP	0.02	0.02	-	-	-	-	-	-
		Sones	2.4	2.3	-	-	-	-	-	-
1/4	1000	CFM	187	144	63	-	-	-	-	-
		BHP	0.02	0.03	0.03	-	-	-	-	-
		Sones	3.1	2.8	3.1	-	-	-	-	-
1/4	1100	CFM	206	167	112	-	-	-	-	-
		BHP	0.03	0.03	0.03	-	-	-	-	-
		Sones	3.9	3.6	3.8	-	-	-	-	-
1/4	1200	CFM	225	189	146	64	-	-	-	-
		BHP	0.04	0.04	0.04	0.04	-	-	-	-
		Sones	4.8	4.5	4.6	4.9	-	-	-	-
1/4	1300	CFM	244	212	174	116	-	-	-	-
		BHP	0.05	0.05	0.06	0.06	-	-	-	-
		Sones	5.8	5.5	5.4	5.7	-	-	-	-
1/4	1400	CFM	262	234	200	157	81	-	-	-
		BHP	0.07	0.07	0.07	0.07	0.07	-	-	-
		Sones	6.8	6.5	6.4	6.6	6.8	-	-	-
1/4	1500	CFM	281	255	223	188	133	56	-	-
		BHP	0.08	0.08	0.08	0.09	0.09	0.09	-	-
		Sones	7.9	7.6	7.4	7.5	7.7	7.9	-	-
1/4	1600	CFM	300	275	246	215	176	109	-	-
		BHP	0.10	0.10	0.10	0.10	0.11	0.11	-	-
		Sones	8.7	8.4	8.2	8.2	8.4	8.6	-	-
1/4	1700	CFM	319	295	268	241	208	160	92	-
		BHP	0.12	0.12	0.12	0.12	0.12	0.13	0.13	-
		Sones	9.5	9.2	8.9	9.0	9.1	9.2	9.4	-
1/4	1800	CFM	337	315	291	265	235	201	144	80
		BHP	0.14	0.14	0.14	0.14	0.15	0.15	0.15	0.15
		Sones	10.3	10.0	9.7	9.7	9.8	9.9	10.1	10.2
1/4	1900	CFM	356	335	313	288	262	232	193	132
		BHP	0.16	0.16	0.17	0.17	0.17	0.17	0.18	0.18
		Sones	11.1	10.8	10.5	10.4	10.5	10.6	10.8	10.9
1/4	2000	CFM	375	355	335	310	288	260	229	184
		BHP	0.19	0.19	0.19	0.19	0.20	0.20	0.20	0.21
		Sones	12.0	11.7	11.4	11.2	11.3	11.3	11.5	11.6

Power Ratings (BHP) does not include drive losses.
 Performance certified is for installation type A - free inlet, free outlet.
 Performance ratings include the effects of birdscreen in the airstream.
 The sound ratings shown are loudness values in fan sones @ 5' (1.5m) in a hemispherical free field calculated per AMCA Standard 301. Values shown are for: Installation Type A: free inlet hemispherical sone levels.



S&P USA Ventilation Systems, LLC., Div. of Soler & Palau Ventilation Group, certifies that the Models SDB shown herein are licensed to bear the AMCA Seal. The ratings shown are based on test and procedures performed in accordance with AMCA Publication 211 and AMCA Publication 311 and comply with the requirement of the AMCA Certified Ratings Program.





SIZE 7

Motor HP	RPM		Static Pressure in Inches w.g.							
			0	0.125	0.25	0.375	0.5	0.625	0.75	0.875
1/4	700	CFM	192	44	-	-	-	-	-	-
		BHP	0.01	0.01	-	-	-	-	-	-
		Sones	1.3	1.4	-	-	-	-	-	-
1/4	800	CFM	219	102	-	-	-	-	-	-
		BHP	0.01	0.01	-	-	-	-	-	-
		Sones	2.1	2.0	-	-	-	-	-	-
1/4	900	CFM	246	150	-	-	-	-	-	-
		BHP	0.02	0.02	-	-	-	-	-	-
		Sones	2.7	2.4	-	-	-	-	-	-
1/4	1000	CFM	274	191	68	-	-	-	-	-
		BHP	0.02	0.03	0.03	-	-	-	-	-
		Sones	3.3	3.0	3.4	-	-	-	-	-
1/4	1100	CFM	301	227	126	-	-	-	-	-
		BHP	0.03	0.03	0.04	-	-	-	-	-
		Sones	4.0	3.7	4.1	-	-	-	-	-
1/4	1200	CFM	328	260	180	69	-	-	-	-
		BHP	0.04	0.04	0.05	0.05	-	-	-	-
		Sones	5.1	4.7	4.9	5.3	-	-	-	-
1/4	1300	CFM	356	293	224	127	-	-	-	-
		BHP	0.05	0.06	0.06	0.06	-	-	-	-
		Sones	6.1	5.7	5.7	6.1	-	-	-	-
1/4	1400	CFM	383	325	264	184	88	-	-	-
		BHP	0.07	0.07	0.07	0.07	0.07	-	-	-
		Sones	7.2	6.8	6.6	6.9	7.3	-	-	-
1/4	1500	CFM	411	357	301	234	146	-	-	-
		BHP	0.08	0.08	0.09	0.09	0.09	-	-	-
		Sones	8.5	8.1	7.7	7.9	8.3	-	-	-
1/4	1600	CFM	438	388	336	277	204	119	-	-
		BHP	0.10	0.10	0.10	0.11	0.11	0.11	-	-
		Sones	9.3	8.9	8.5	8.6	8.9	9.2	-	-
1/4	1700	CFM	465	419	369	318	256	177	-	-
		BHP	0.12	0.12	0.12	0.13	0.13	0.13	-	-
		Sones	10.1	9.7	9.4	9.2	9.5	9.8	-	-
1/4	1800	CFM	493	449	402	356	300	234	158	-
		BHP	0.14	0.14	0.15	0.15	0.15	0.15	0.16	-
		Sones	10.9	10.6	10.2	9.9	10.1	10.4	10.7	-
1/4	1900	CFM	520	478	434	391	342	286	216	145
		BHP	0.16	0.17	0.17	0.17	0.18	0.18	0.18	0.18
		Sones	11.7	11.4	11.1	10.8	10.8	11.1	11.3	11.6
1/4	2000	CFM	547	507	466	425	381	330	272	202
		BHP	0.19	0.19	0.20	0.20	0.20	0.21	0.21	0.21
		Sones	12.5	12.2	11.9	11.7	11.5	11.7	12.0	12.3

Power Ratings (BHP) does not include drive losses.

Performance certified is for installation type A - free inlet, free outlet.

Performance ratings include the effects of birdscreen in the airstream.

The sound ratings shown are loudness values in fan sones @ 5' (1.5m) in a hemispherical free field calculated per AMCA Standard 301. Values shown are for: Installation Type A: free inlet hemispherical sone levels.



S&P USA Ventilation Systems, LLC., Div. of Soler & Palau Ventilation Group, certifies that the Models SDB shown herein are licensed to bear the AMCA Seal. The ratings shown are based on test and procedures performed in accordance with AMCA Publication 211 and AMCA Publication 311 and comply with the requirement of the AMCA Certified Ratings Program.





SIZE 8

Motor HP	RPM		Static Pressure in Inches w.g.								
			0	0.125	0.25	0.375	0.5	0.625	0.75	0.875	1
1/4	700	CFM	377	194	-	-	-	-	-	-	-
		BHP	0.01	0.01	-	-	-	-	-	-	-
		Sones	2.0	1.4	-	-	-	-	-	-	-
1/4	800	CFM	431	302	-	-	-	-	-	-	-
		BHP	0.02	0.02	-	-	-	-	-	-	-
		Sones	2.9	2.4	-	-	-	-	-	-	-
1/4	900	CFM	485	378	-	-	-	-	-	-	-
		BHP	0.02	0.03	-	-	-	-	-	-	-
		Sones	3.8	3.1	-	-	-	-	-	-	-
1/4	1000	CFM	539	445	293	-	-	-	-	-	-
		BHP	0.03	0.03	0.04	-	-	-	-	-	-
		Sones	4.6	3.9	3.6	-	-	-	-	-	-
1/4	1100	CFM	593	508	403	-	-	-	-	-	-
		BHP	0.04	0.04	0.05	-	-	-	-	-	-
		Sones	5.4	4.7	4.6	-	-	-	-	-	-
1/4	1200	CFM	647	570	481	310	-	-	-	-	-
		BHP	0.05	0.05	0.06	0.06	-	-	-	-	-
		Sones	6.3	5.7	5.6	5.2	-	-	-	-	-
1/4	1300	CFM	701	630	553	450	-	-	-	-	-
		BHP	0.06	0.07	0.07	0.08	-	-	-	-	-
		Sones	7.2	6.8	6.6	6.4	-	-	-	-	-
1/4	1400	CFM	754	688	620	535	-	-	-	-	-
		BHP	0.08	0.08	0.09	0.10	-	-	-	-	-
		Sones	8.3	7.9	7.6	7.6	-	-	-	-	-
1/4	1500	CFM	808	746	684	612	519	-	-	-	-
		BHP	0.10	0.10	0.11	0.12	0.12	-	-	-	-
		Sones	9.5	9.0	8.6	8.7	8.5	-	-	-	-
1/4	1600	CFM	862	803	747	683	605	492	-	-	-
		BHP	0.12	0.12	0.13	0.14	0.14	0.14	-	-	-
		Sones	10.4	10.0	9.6	9.5	9.5	9.1	-	-	-
1/4	1700	CFM	916	860	808	750	683	602	445	-	-
		BHP	0.14	0.15	0.16	0.16	0.17	0.17	0.17	-	-
		Sones	11.6	10.9	10.6	10.4	10.4	10.2	9.9	-	-
1/4	1800	CFM	970	917	868	814	755	685	598	395	-
		BHP	0.17	0.18	0.18	0.19	0.20	0.20	0.20	0.19	-
		Sones	12.8	12.1	11.6	11.3	11.3	11.3	10.9	10.6	-
1/4	1900	CFM	1024	973	927	877	824	763	693	592	-
		BHP	0.20	0.21	0.21	0.22	0.23	0.24	0.24	0.24	-
		Sones	13.8	13.2	12.6	12.3	12.2	12.2	12.1	11.8	-
1/3	2000	CFM	1078	1029	985	939	890	836	773	702	586
		BHP	0.23	0.24	0.25	0.25	0.27	0.27	0.28	0.28	0.28
		Sones	15.0	14.3	13.8	13.3	13.1	13.1	13.2	12.9	12.7
1/3	2100	CFM	1132	1085	1043	1000	954	905	850	787	712
		BHP	0.26	0.28	0.28	0.29	0.30	0.31	0.32	0.32	0.33
		Sones	16.1	15.5	15.0	14.5	14.0	14.1	14.1	14.1	13.8

Power Ratings (BHP) does not include drive losses.
 Performance certified is for installation type A - free inlet, free outlet.
 Performance ratings include the effects of birdscreen in the airstream.
 The sound ratings shown are loudness values in fan sones @ 5' (1.5m) in a hemispherical free field calculated per AMCA Standard 301. Values shown are for: Installation Type A: free inlet hemispherical sone levels.



S&P USA Ventilation Systems, LLC., Div. of Soler & Palau Ventilation Group, certifies that the Models SDB shown herein are licensed to bear the AMCA Seal. The ratings shown are based on test and procedures performed in accordance with AMCA Publication 211 and AMCA Publication 311 and comply with the requirement of the AMCA Certified Ratings Program.





SIZE 10

Motor HP	RPM		Static Pressure in Inches w.g.								
			0	0.125	0.25	0.375	0.5	0.625	0.75	0.875	1
1/4	700	CFM	586	423	-	-	-	-	-	-	-
		BHP	0.02	0.02	-	-	-	-	-	-	-
		Sones	3.1	2.6	-	-	-	-	-	-	-
1/4	800	CFM	669	537	244	-	-	-	-	-	-
		BHP	0.02	0.03	0.03	-	-	-	-	-	-
		Sones	4.1	3.5	3.5	-	-	-	-	-	-
1/4	900	CFM	753	639	479	-	-	-	-	-	-
		BHP	0.03	0.04	0.05	-	-	-	-	-	-
		Sones	5.1	4.5	4.3	-	-	-	-	-	-
1/4	1000	CFM	837	737	610	374	-	-	-	-	-
		BHP	0.05	0.06	0.06	0.06	-	-	-	-	-
		Sones	6.0	5.5	5.2	5.3	-	-	-	-	-
1/4	1100	CFM	920	832	725	583	-	-	-	-	-
		BHP	0.06	0.07	0.08	0.08	-	-	-	-	-
		Sones	7.1	6.6	6.4	6.3	-	-	-	-	-
1/4	1200	CFM	1004	924	830	717	562	-	-	-	-
		BHP	0.08	0.09	0.10	0.11	0.11	-	-	-	-
		Sones	8.3	7.8	7.5	7.3	7.4	-	-	-	-
1/4	1300	CFM	1088	1014	931	836	716	513	-	-	-
		BHP	0.10	0.11	0.12	0.13	0.14	0.14	-	-	-
		Sones	9.6	9.1	8.8	8.6	8.5	8.7	-	-	-
1/4	1400	CFM	1171	1104	1029	945	846	725	-	-	-
		BHP	0.13	0.14	0.15	0.16	0.17	0.17	-	-	-
		Sones	11.1	10.5	10.1	10.0	9.8	9.9	-	-	-
1/3	1500	CFM	1255	1192	1124	1048	964	863	744	-	-
		BHP	0.16	0.17	0.18	0.19	0.20	0.21	0.21	-	-
		Sones	12.6	12.1	11.5	11.4	11.3	11.2	11.3	-	-
1/3	1600	CFM	1339	1280	1217	1148	1073	988	888	768	-
		BHP	0.19	0.21	0.22	0.23	0.24	0.25	0.26	0.26	-
		Sones	13.8	13.3	12.8	12.6	12.5	12.3	12.3	12.4	-
1/3	1700	CFM	1422	1368	1309	1246	1177	1103	1018	920	801
		BHP	0.23	0.24	0.26	0.27	0.28	0.30	0.31	0.31	0.31
		Sones	15.1	14.6	14.1	13.8	13.7	13.5	13.4	13.5	13.6

Power Ratings (BHP) does not include drive losses.

Performance certified is for installation type A - free inlet, free outlet.

Performance ratings include the effects of birdscreen in the airstream.

The sound ratings shown are loudness values in fan sones @ 5' (1.5m) in a hemispherical free field calculated per AMCA Standard 301. Values shown are for: Installation Type A: free inlet hemispherical sone levels.



S&P USA Ventilation Systems, LLC., Div. of Soler & Palau Ventilation Group, certifies that the Models SDB shown herein are licensed to bear the AMCA Seal. The ratings shown are based on test and procedures performed in accordance with AMCA Publication 211 and AMCA Publication 311 and comply with the requirement of the AMCA Certified Ratings Program.





SIZE 12

Motor HP	RPM		Static Pressure in Inches w.g.										
			0	0.125	0.25	0.375	0.5	0.625	0.75	0.875	1	1.25	
1/4	600	CFM	660	425	-	-	-	-	-	-	-	-	-
		BHP	0.01	0.02	-	-	-	-	-	-	-	-	-
		Sones	2.5	2.1	-	-	-	-	-	-	-	-	-
1/4	700	CFM	770	585	-	-	-	-	-	-	-	-	-
		BHP	0.02	0.03	-	-	-	-	-	-	-	-	-
		Sones	3.5	3.2	-	-	-	-	-	-	-	-	-
1/4	800	CFM	880	726	509	-	-	-	-	-	-	-	-
		BHP	0.03	0.04	0.05	-	-	-	-	-	-	-	-
		Sones	4.5	4.2	3.9	-	-	-	-	-	-	-	-
1/4	900	CFM	990	859	690	-	-	-	-	-	-	-	-
		BHP	0.05	0.06	0.07	-	-	-	-	-	-	-	-
		Sones	5.6	5.3	5.0	-	-	-	-	-	-	-	-
1/4	1000	CFM	1100	987	842	665	-	-	-	-	-	-	-
		BHP	0.07	0.08	0.09	0.09	-	-	-	-	-	-	-
		Sones	6.6	6.4	6.1	5.9	-	-	-	-	-	-	-
1/4	1100	CFM	1210	1108	983	842	638	-	-	-	-	-	-
		BHP	0.09	0.10	0.11	0.12	0.12	-	-	-	-	-	-
		Sones	7.7	7.5	7.2	7.0	6.8	-	-	-	-	-	-
1/4	1200	CFM	1320	1227	1119	995	850	-	-	-	-	-	-
		BHP	0.11	0.13	0.14	0.15	0.16	-	-	-	-	-	-
		Sones	8.9	8.7	8.4	8.2	8.0	-	-	-	-	-	-
1/4	1300	CFM	1430	1343	1251	1138	1020	876	-	-	-	-	-
		BHP	0.15	0.16	0.17	0.19	0.19	0.20	-	-	-	-	-
		Sones	10.2	10.0	9.7	9.4	9.2	9.1	-	-	-	-	-
1/4	1400	CFM	1540	1459	1378	1277	1170	1053	913	-	-	-	-
		BHP	0.18	0.20	0.21	0.23	0.24	0.25	0.25	-	-	-	-
		Sones	11.5	11.3	11.1	10.8	10.5	10.4	10.3	-	-	-	-
1/3	1500	CFM	1650	1574	1500	1411	1313	1212	1096	960	-	-	-
		BHP	0.22	0.24	0.26	0.27	0.28	0.30	0.30	0.31	-	-	-
		Sones	12.9	12.7	12.6	12.3	11.9	11.8	11.7	11.6	-	-	-
1/2	1600	CFM	1760	1689	1620	1542	1452	1358	1261	1147	1019	-	-
		BHP	0.27	0.29	0.31	0.32	0.34	0.35	0.36	0.37	0.37	-	-
		Sones	14.2	14.0	13.9	13.7	13.4	13.1	12.9	12.8	12.7	-	-
1/2	1700	CFM	1870	1803	1738	1669	1587	1500	1411	1318	1207	872	-
		BHP	0.32	0.34	0.36	0.38	0.40	0.41	0.43	0.44	0.44	0.43	-
		Sones	15.6	15.4	15.3	15.1	14.8	14.5	14.3	14.2	14.0	13.9	-

Power Ratings (BHP) does not include drive losses.

Performance certified is for installation type A - free inlet, free outlet.

Performance ratings include the effects of birdscreen in the airstream.

The sound ratings shown are loudness values in fan sones @ 5' (1.5m) in a hemispherical free field calculated per AMCA Standard 301. Values shown are for: Installation Type A: free inlet hemispherical sone levels.



S&P USA Ventilation Systems, LLC., Div. of Soler & Palau Ventilation Group, certifies that the Models SDB shown herein are licensed to bear the AMCA Seal. The ratings shown are based on test and procedures performed in accordance with AMCA Publication 211 and AMCA Publication 311 and comply with the requirement of the AMCA Certified Ratings Program.





SIZE 14

Motor HP	RPM		Static Pressure in Inches w.g.											
			0	0.125	0.25	0.375	0.5	0.625	0.75	0.875	1	1.25	1.5	
1/4	550	CFM	1108	802	-	-	-	-	-	-	-	-	-	-
		BHP	0.03	0.03	-	-	-	-	-	-	-	-	-	-
		Sones	3.4	2.4	-	-	-	-	-	-	-	-	-	-
1/4	650	CFM	1309	1070	-	-	-	-	-	-	-	-	-	-
		BHP	0.04	0.05	-	-	-	-	-	-	-	-	-	-
		Sones	4.6	3.7	-	-	-	-	-	-	-	-	-	-
1/4	750	CFM	1511	1312	1048	-	-	-	-	-	-	-	-	-
		BHP	0.07	0.08	0.09	-	-	-	-	-	-	-	-	-
		Sones	6.2	5.2	4.8	-	-	-	-	-	-	-	-	-
1/4	850	CFM	1712	1539	1332	1016	-	-	-	-	-	-	-	-
		BHP	0.10	0.11	0.12	0.12	-	-	-	-	-	-	-	-
		Sones	7.8	6.8	6.1	6.0	-	-	-	-	-	-	-	-
1/4	950	CFM	1914	1759	1591	1382	-	-	-	-	-	-	-	-
		BHP	0.13	0.15	0.16	0.17	-	-	-	-	-	-	-	-
		Sones	9.1	8.3	7.5	7.1	-	-	-	-	-	-	-	-
1/4	1050	CFM	2115	1975	1831	1655	1446	-	-	-	-	-	-	-
		BHP	0.18	0.19	0.21	0.23	0.23	-	-	-	-	-	-	-
		Sones	10.6	9.8	9.1	8.7	8.4	-	-	-	-	-	-	-
1/3	1150	CFM	2316	2188	2060	1914	1745	1531	-	-	-	-	-	-
		BHP	0.23	0.25	0.27	0.29	0.30	0.31	-	-	-	-	-	-
		Sones	12.2	11.5	10.9	10.4	10.0	9.9	-	-	-	-	-	-
1/2	1250	CFM	2518	2399	2283	2157	2011	1852	1639	-	-	-	-	-
		BHP	0.30	0.31	0.34	0.36	0.38	0.39	0.40	-	-	-	-	-
		Sones	14.0	13.4	12.8	12.3	11.9	11.5	11.5	-	-	-	-	-
1/2	1350	CFM	2719	2609	2502	2390	2266	2122	1973	1770	-	-	-	-
		BHP	0.38	0.39	0.42	0.44	0.46	0.48	0.49	0.50	-	-	-	-
		Sones	16.1	15.5	14.8	14.3	13.9	13.4	13.1	13.1	-	-	-	-
3/4	1450	CFM	2921	2818	2718	2616	2507	2384	2248	2107	1918	-	-	-
		BHP	0.47	0.48	0.51	0.53	0.56	0.58	0.60	0.61	0.62	-	-	-
		Sones	18.1	17.5	17.0	16.4	16.0	15.6	15.3	14.9	14.9	-	-	-
3/4	1550	CFM	3122	3026	2931	2838	2739	2633	2512	2385	2252	1846	-	-
		BHP	0.57	0.59	0.61	0.64	0.67	0.70	0.72	0.74	0.75	0.75	-	-
		Sones	20.2	19.6	19.0	18.3	17.8	17.5	17.2	16.8	16.5	16.9	-	-
1	1650	CFM	3324	3233	3144	3056	2966	2871	2766	2651	2531	2251	1756	-
		BHP	0.69	0.71	0.73	0.76	0.79	0.82	0.85	0.87	0.89	0.91	0.87	-
		Sones	22.0	21.4	20.8	20.3	19.7	19.4	19.0	18.7	18.3	17.8	18.6	-
1	1750	CFM	3525	3440	3355	3273	3189	3102	3009	2908	2797	2568	2247	-
		BHP	0.83	0.84	0.86	0.89	0.93	0.96	0.99	1.02	1.04	1.07	1.08	-
		Sones	24.2	23.6	22.9	22.2	21.6	21.1	20.7	20.4	20.1	19.5	19.6	-

Power Ratings (BHP) does not include drive losses.

Performance certified is for installation type A - free inlet, free outlet.

Performance ratings include the effects of birdscreen in the airstream.

The sound ratings shown are loudness values in fan sones @ 5' (1.5m) in a hemispherical free field calculated per AMCA Standard 301. Values shown are for: Installation Type A: free inlet hemispherical sone levels.



S&P USA Ventilation Systems, LLC., Div. of Soler & Palau Ventilation Group, certifies that the Models SDB shown herein are licensed to bear the AMCA Seal. The ratings shown are based on test and procedures performed in accordance with AMCA Publication 211 and AMCA Publication 311 and comply with the requirement of the AMCA Certified Ratings Program.





SIZE 15

Motor HP	RPM		Static Pressure in Inches w.g.											
			0	0.125	0.25	0.375	0.5	0.625	0.75	0.875	1	1.25	1.5	
1/4	500	CFM	1164	843	-	-	-	-	-	-	-	-	-	-
		BHP	0.02	0.03	-	-	-	-	-	-	-	-	-	-
		Sones	3.3	2.4	-	-	-	-	-	-	-	-	-	-
1/4	600	CFM	1396	1146	543	-	-	-	-	-	-	-	-	
		BHP	0.04	0.05	0.05	-	-	-	-	-	-	-	-	
		Sones	4.6	3.9	2.8	-	-	-	-	-	-	-	-	
1/4	700	CFM	1629	1421	1168	-	-	-	-	-	-	-	-	
		BHP	0.06	0.08	0.09	-	-	-	-	-	-	-	-	
		Sones	6.1	5.5	4.6	-	-	-	-	-	-	-	-	
1/4	800	CFM	1862	1685	1478	1206	-	-	-	-	-	-	-	
		BHP	0.09	0.11	0.12	0.13	-	-	-	-	-	-	-	
		Sones	7.9	7.2	6.6	5.6	-	-	-	-	-	-	-	
1/4	900	CFM	2095	1944	1766	1570	1278	-	-	-	-	-	-	
		BHP	0.13	0.15	0.17	0.18	0.19	-	-	-	-	-	-	
		Sones	9.7	9.0	8.3	7.7	6.7	-	-	-	-	-	-	
1/3	1000	CFM	2327	2197	2037	1870	1687	1393	-	-	-	-	-	
		BHP	0.18	0.20	0.22	0.24	0.26	0.26	-	-	-	-	-	
		Sones	11.1	10.5	10.0	9.5	8.7	7.9	-	-	-	-	-	
1/3	1100	CFM	2560	2445	2301	2156	1996	1823	1553	-	-	-	-	
		BHP	0.23	0.26	0.28	0.31	0.33	0.35	0.35	-	-	-	-	
		Sones	12.7	12.2	11.7	11.2	10.7	9.9	9.1	-	-	-	-	
1/2	1200	CFM	2793	2690	2562	2429	2291	2143	1980	1739	-	-	-	
		BHP	0.30	0.33	0.36	0.38	0.41	0.43	0.45	0.45	-	-	-	
		Sones	14.3	13.9	13.5	13.1	12.6	12.1	11.3	10.5	-	-	-	
3/4	1300	CFM	3026	2932	2818	2694	2572	2441	2304	2152	1938	-	-	
		BHP	0.39	0.42	0.44	0.47	0.50	0.53	0.55	0.57	0.57	-	-	
		Sones	16.3	15.8	15.3	15.0	14.7	14.5	13.9	12.9	12.0	-	-	
3/4	1400	CFM	3258	3172	3071	2956	2843	2728	2602	2476	2336	1876	-	
		BHP	0.48	0.51	0.55	0.57	0.61	0.64	0.66	0.69	0.71	0.71	-	
		Sones	18.6	18.1	17.7	17.3	17.0	16.9	16.7	16.1	14.9	13.2	-	
1	1500	CFM	3491	3412	3321	3216	3107	3003	2893	2775	2657	2373	-	
		BHP	0.59	0.63	0.66	0.69	0.72	0.76	0.79	0.82	0.84	0.88	-	
		Sones	20.9	20.5	20.0	19.6	19.5	19.3	19.2	19.1	18.4	16.1	-	
1	1600	CFM	3724	3650	3567	3472	3370	3271	3172	3067	2956	2729	2412	
		BHP	0.72	0.76	0.79	0.83	0.86	0.89	0.93	0.96	0.99	1.05	1.07	
		Sones	23.3	22.9	22.4	21.9	21.5	21.1	21.0	20.8	20.7	19.0	17.3	

Power Ratings (BHP) does not include drive losses.

Performance certified is for installation type A - free inlet, free outlet.

Performance ratings include the effects of birdscreen in the airstream.

The sound ratings shown are loudness values in fan sones @ 5' (1.5m) in a hemispherical free field calculated per AMCA Standard 301. Values shown are for: Installation Type A: free inlet hemispherical sone levels.



S&P USA Ventilation Systems, LLC., Div. of Soler & Palau Ventilation Group, certifies that the Models SDB shown herein are licensed to bear the AMCA Seal. The ratings shown are based on test and procedures performed in accordance with AMCA Publication 211 and AMCA Publication 311 and comply with the requirement of the AMCA Certified Ratings Program.





SIZE 16

Motor HP	RPM		Static Pressure in Inches w.g.											
			0	0.125	0.25	0.375	0.5	0.625	0.75	0.875	1	1.25	1.5	
1/4	550	CFM	1568	1275	-	-	-	-	-	-	-	-	-	-
		BHP	0.04	0.06	-	-	-	-	-	-	-	-	-	-
		Sones	4.4	3.5	-	-	-	-	-	-	-	-	-	-
1/4	650	CFM	1853	1614	1292	-	-	-	-	-	-	-	-	
		BHP	0.07	0.08	0.10	-	-	-	-	-	-	-	-	
		Sones	6.0	5.1	4.3	-	-	-	-	-	-	-	-	
1/4	750	CFM	2139	1936	1702	1356	-	-	-	-	-	-	-	
		BHP	0.10	0.12	0.14	0.15	-	-	-	-	-	-	-	
		Sones	7.8	7.3	6.2	5.6	-	-	-	-	-	-	-	
1/4	850	CFM	2424	2249	2052	1817	1502	-	-	-	-	-	-	
		BHP	0.15	0.17	0.20	0.21	0.22	-	-	-	-	-	-	
		Sones	9.5	8.9	8.1	7.3	6.9	-	-	-	-	-	-	
1/3	950	CFM	2709	2556	2383	2198	1964	1678	-	-	-	-	-	
		BHP	0.21	0.23	0.26	0.28	0.30	0.31	-	-	-	-	-	
		Sones	11.2	10.7	10.1	9.2	8.6	8.2	-	-	-	-	-	
1/2	1050	CFM	2994	2857	2704	2543	2368	2142	1878	-	-	-	-	
		BHP	0.28	0.31	0.34	0.37	0.39	0.41	0.41	-	-	-	-	
		Sones	12.9	12.5	12.1	11.3	10.5	10.0	9.6	-	-	-	-	
3/4	1150	CFM	3279	3156	3019	2874	2724	2557	2345	2095	-	-	-	
		BHP	0.37	0.40	0.43	0.46	0.49	0.52	0.53	0.54	-	-	-	
		Sones	14.7	14.4	14.0	13.4	12.6	11.9	11.5	11.3	-	-	-	
3/4	1250	CFM	3564	3452	3329	3197	3062	2921	2763	2568	2348	-	-	
		BHP	0.47	0.51	0.54	0.58	0.61	0.64	0.66	0.68	0.70	-	-	
		Sones	16.9	16.5	16.3	16.0	15.1	14.4	13.7	13.5	13.3	-	-	
1	1350	CFM	3849	3746	3634	3514	3391	3264	3132	2983	2805	2402	-	
		BHP	0.59	0.63	0.67	0.71	0.75	0.78	0.81	0.84	0.86	0.88	-	
		Sones	19.4	19.2	18.9	18.6	18.0	17.3	16.5	15.8	15.5	15.1	-	
1	1450	CFM	4135	4038	3936	3827	3713	3597	3478	3354	3216	2875	2467	
		BHP	0.74	0.78	0.82	0.86	0.90	0.94	0.97	1.01	1.04	1.08	1.08	
		Sones	22.2	21.9	21.7	21.5	21.3	20.4	19.6	18.8	18.0	17.5	17.0	

Power Ratings (BHP) does not include drive losses.

Performance certified is for installation type A - free inlet, free outlet.

Performance ratings include the effects of birdscreen in the airstream.

The sound ratings shown are loudness values in fan sones @ 5' (1.5m) in a hemispherical free field calculated per AMCA Standard 301. Values shown are for: Installation Type A: free inlet hemispherical sone levels.



S&P USA Ventilation Systems, LLC., Div. of Soler & Palau Ventilation Group, certifies that the Models SDB shown herein are licensed to bear the AMCA Seal. The ratings shown are based on test and procedures performed in accordance with AMCA Publication 211 and AMCA Publication 311 and comply with the requirement of the AMCA Certified Ratings Program.





Upblast Model Overview & Construction Features

Model STXB - Belt Drive

Size Range	8, 10, 12, 14, 15 & 16
Motor HP Range	1/4 to 1-1/2
CFM Range	200 to 3975
Static Pressure	up to 1-1/2 in. w.g.
Mounting	Suitable for Roof or Wall
Warranty	5 years/2 years for RHUL models

Models STXD & STXDe* - Direct Drive

Size Range	6, 7, 8, 10, 12, 14, 15 & 16
Motor HP Range	1/25 to 1-1/2
CFM Range	55 to 4780
Static Pressure	up to 1-1/2 in. w.g.
Mounting	Suitable for Roof or Wall
Warranty	5 years/2 years for RHUL models

*Models STXDe have Electronically Commutated (EC) Motors



Applications

Exhaust Contaminated, Grease Laden and/or High Temperature Air

- Restaurant Hoods/Kitchen Ventilation
- Fume and Smoke Removal
- Laboratory Fume Hoods
- Chemical Process Exhaust



Upblast Model Overview & Construction Features

#	Feature	Description
1	Motor Cover	Heavy-gauge aluminum motor cover provides weather protection for motor compartment.
2	Motor Cover Cap	Heavy-gauge aluminum top with rolled bead for added strength and quick-release latches.
3	Quick-Release Latches	Stainless steel latches for easy removal of motor cover cap for access to the motor compartment and motor.
4	Motor	Open drip-proof enclosure standard on STXD & STXB and many other options are available. Model STXDe comes standard with Electronically Commutated (EC) motors. See page 47 for additional EC motor information.
5	Bearings	Air handling ball bearing type with cast iron housing and grease fittings.
6	Vibration Isolators	Neoprene (rubber) vibration isolators to reduce vibration and noise.
7	Motor Mounting Plate	Heavy-gauge galvanized motor mounting plate.
8	Wheel	Aluminum, non-overloading, backward-inclined, curved centrifugal wheel for maximum efficiency. Each wheel is dynamically balanced for smooth operation and long life.
9	Cooling Vanes	Helps promote cooling of the motor and drive by pulling air through the motor compartment. Helps maximize the life of the motor and drives.
10	Curved Blades	Designed to provide more CFM per HP and lower sound levels.
11	Support Legs	4 heavy-gauge galvanized support legs to anchor the motor plate to the fan base for stability and vibration reduction.
12	Shroud	Spun aluminum fan shroud with rolled bead for extra strength. Fan shroud directs the exhausted air upward away from the mounting surface.
13	Exterior Fasteners	Stainless steel.
14	Inlet Venturi	Deep spun single piece inlet venturi for optimum air and sound performance
15	Curb Cap	Fully welded curb cap for rigidity and weather protection. Pre-punched mounting holes for ease of installation.
16	Drives	Sized for 150% of drive HP, adjustable pitch motor sheaves.
17	Lifting Lugs	Standard on all belt drive models, STXB, for easy and safe placement of the fan on roof.
18	Vent Tube	Oversized vent tube for maximum motor cooling.
19	Grease Drain Fitting	Grease drain fitting for connection of Grease Trough or Grease Grabber.
20	Disconnect Switch (not shown)	Standard with ODP and TE single speed motors. Ships loose.



DIMENSIONS

Dimensions in Inches

Model STXD & STXDe: Direct Drive Centrifugal Upblast

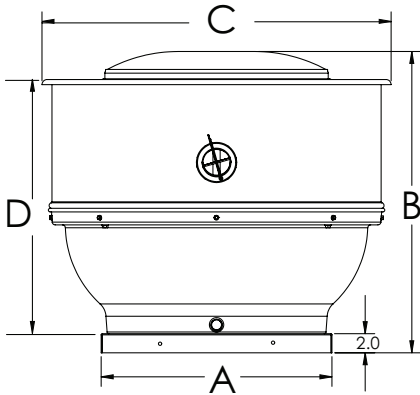

Size	A	B	C	D	Roof Opening	Curb O.D.	Damper (O.D.)	Average Ship Wt. Lbs.
6	18 1/8	25 1/2	28 5/8	19 3/4	13 1/2	16 1/2	12	90
7	18 1/8	25 1/2	28 5/8	19 3/4	13 1/2	16 1/2	12	89
8	18 1/8	25 1/2	28 5/8	19 3/4	13 1/2	16 1/2	12	98
10	18 1/8	25 1/2	28 5/8	19 3/4	13 1/2	16 1/2	12	114
12	20 1/8	27 1/8	31 1/4	21 3/8	15 1/2	18 1/2	14	118
14	20 1/8	27 1/8	31 1/4	21 3/8	15 1/2	18 1/2	14	117
15	24 1/8	27 7/8	36 1/2	22	19 1/2	22 1/2	18	135
16	24 1/8	27 7/8	36 1/2	22	19 1/2	22 1/2	18	136

Model STXB: Belt Drive Centrifugal Upblast

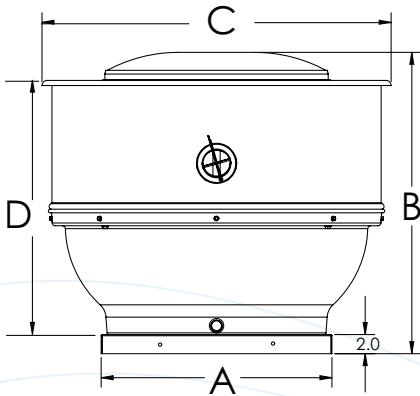

Size	A	B	C	D	Roof Opening	Curb O.D.	Damper (O.D.)	Average Ship Wt. Lbs.
8	18 1/8	29 1/3	28 5/8	24 1/3	13 1/2	16 1/2	12	123
10	18 1/8	29 1/3	28 5/8	24 1/3	13 1/2	16 1/2	12	124
12	20 1/8	30 7/8	31 1/3	25 7/8	15 1/2	18 1/2	14	136
14	20 1/8	30 7/8	31 1/3	25 7/8	15 1/2	18 1/2	14	138
15	24 1/8	31 3/8	36 1/2	26 5/8	19 1/2	22 1/2	18	155
16	24 1/8	31 3/8	36 1/2	26 5/8	19 1/2	22 1/2	18	155



OPTIONS/ACCESSORIES

Solid State Speed Control (STXD): S&P's solid state control is matched to the motor and blower wheel to allow continuous reduction in performance allowing adjustments of airflow for system balancing. CFM is reduced in direct proportion to motor speed reduction. Speed control is available for 115 or 230 volt single phase. Exhauster performance can be controlled from the ventilated area.



Constant Pressure Controls (STXDe): (Not for UL762 use) For constant pressure control applications, the S&P constant pressure control package is available. This package includes the components that are needed to complete a demand-based exhaust ventilation system for kitchens, bathrooms, and/or clothes dryer exhaust in multi-story buildings. S&P recognized that the programming procedure for many constant pressure controls can be challenging, so this package is the simplest system available. The control box can be easily installed in the field, either mounted on a curb or inside the building. The backlit LCD display and pressure transducer are pre-programmed to work together to increase or reduce the speed of the fan to accommodate for the actual demand.

Potentiometer Shipped Loose (STXDe): (Not for UL762 use) If a variable rate that is manually changed by the operator from the occupied space is desired, the potentiometer is shipped loose and field installed in the appropriate accessible location. Simply rotating the dial will vary the speed of the fan from 20% to 100% full speed.

Automatic Belt Tensioner (STXB): Available on sizes 8-16, The Automatic Belt Tensioners eliminate the need for regular manual retensioning of drives, and the risk of inadvertently over-tensioning drive components is avoided and overall drive operating efficiency is enhanced. Benefits include reduction in startup and maintenance costs, increased belt life, increased drive efficiency, and ensure drive components do not snag obstructions.

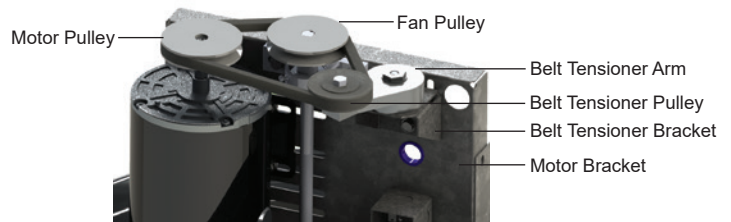

Roof Curb: Prefabricated heavy-gauge galvanized steel, welded construction, 12" high (other heights are also available) with 1-1/2" wood nailer. Assures perfect fit of exhauster to roof opening. Options include burglar bars, single or double pitch construction and hinged curbs for easy duct access.

Common Curb: Designed to allow both the supply fan and exhaust fan to be mounted on the same curb. This curb requires only one roof opening and speeds installation time.



Motor Operated Damper: Motor operated aluminum damper for positive closure against backdraft. (Not for UL762 use).



Automatic Damper: Automatic aluminum damper for ease in installation and effective backdraft protection. (Not for UL762 use).

Grease Grabber or Aluminum Grease Trough: Trap designed for fast and inexpensive replacement. Grease collects in a container for safe and sanitary disposal. Keeps roof clean with proper use.

Curb Hinge Arrangement: The curb hinge arrangement provides easy access to the exhaust fan, backdraft damper, and duct for servicing and cleaning.

Wheel Cleaning Port: 4" diameter port for access to clean the outside of the wheel. Meets NFPA 96 standards. (Ships loose for installation in the field).



Birdscreen: To protect the fan from birds and other large objects. (Ships installed when ordered with Build-to-order fans; ships loose when ordered with stock fans / Quickship)

Insect Screen: Helps prevent insects, snow, airborne mist or water droplets from entering. (Ships installed when ordered with Build-to-order fans)

Special Coatings: Powered roof exhausters often require special coatings for protective and decorative purposes. Available coatings include: Synthetic Resin, Epoxy, and Heresite (air-dried phenolic). Contact your representative or the factory for more information on available coatings and colors.



CONSTRUCTION/SPECIFICATION CHECKLIST

Housing

- Curb cap with integral deep single piece spun inlet for efficient performance and prevention of leakage into ductwork.
- Heavy-gauge aluminum housing and curb cap for strength and rigidity. Curb cap is galvanized steel on all UL762 units.
- Stainless steel exterior fasteners.
- Enclosed, ventilated motor compartment isolates motor from exhaust air.
- Neoprene isolators for reduction of vibration and sound.
- Quick-Release latches on motor cover for easy access to motor compartment.
- Water-tight conduit tube for easy electrical connection without having to wire through the breather tube.
- NFPA - Model STXD is suitable for National Fire Protection Association installations. Contact factory for required accessories.

Centrifugal Wheel

- All aluminum wheel.
- Backward-inclined for efficiency at higher static pressure.
- Non-overloading for safe operation in ducted systems.
- Curved blades for efficiency and quiet operation.
- Dynamically balanced for smooth operation.

Speed Controllable Motors (STXD)

- Brands are nationally recognized and locally serviced.
- Standard motors are single speed, speed controllable and drip-proof.
- All motors are rated for continuous duty.
- Disconnect switch is standard with drip-proof motors.
- Heavy-gauge steel motor brackets designed for maximum strength.

Electronically Commutated Motors (STXDe)

- Brands are nationally recognized and locally serviced.
- Easy speed control by DC 0-10 V variation.
- Motor has motor mounted potentiometer with digital readout for easy speed adjustment.
- Can be controlled by a PC or building management system.
- Motor has 80% usable turndown vs. 30% on a PSC motor.
- Internal motor circuitry converts 115/230 V single phase AC power to DC voltage for increased efficiencies.
- All motors are rated for continuous duty.
- Motor is 115/230V and 50/60 Hz.
- Disconnect is standard.
- Motors ship mounted as standard.

AMCA Seal

- Assures accuracy of Air and Sound Performance.

cULus Label

- cULus 705 Listed Power Roof Ventilator label assures electrical reliability.



SIZE 6

Motor HP	RPM		Static Pressure in Inches w.g.							
			0	.125	.25	.375	.5	.625	.75	
STXD6C 1/10 HP 1550 RPM	900	CFM	125	92	-	-	-	-	-	-
		BHP	0.01	0.01	-	-	-	-	-	-
		Sones	2.1	1.7	-	-	-	-	-	-
	1050	CFM	145	119	81	-	-	-	-	-
		BHP	0.01	0.01	0.01	-	-	-	-	-
		Sones	3.1	2.6	2.7	-	-	-	-	-
	1200	CFM	166	144	117	61	-	-	-	-
		BHP	0.01	0.02	0.02	0.02	-	-	-	-
		Sones	4.2	3.7	3.6	3.8	-	-	-	-
	1350	CFM	187	168	145	116	56	-	-	-
		BHP	0.02	0.02	0.02	0.03	0.03	-	-	-
		Sones	5.4	4.9	4.8	4.8	5.0	-	-	-
	1500	CFM	208	190	170	149	119	58	-	-
		BHP	0.03	0.03	0.03	0.03	0.04	0.04	-	-
		Sones	6.6	6.1	5.9	5.9	6.0	6.2	-	-
	1650	CFM	225	208	191	172	149	115	56	-
		BHP	0.04	0.04	0.04	0.04	0.04	0.05	0.04	-
		Sones	7.5	7.1	6.9	6.8	6.8	6.9	7.1	-
STXD6 1/10 HP 1550 RPM	900	CFM	170	123	-	-	-	-	-	-
		BHP	0.01	0.01	-	-	-	-	-	-
		Sones	2.1	1.8	-	-	-	-	-	-
	1050	CFM	199	160	95	-	-	-	-	-
		BHP	0.01	0.01	0.01	-	-	-	-	-
		Sones	3.0	2.7	2.8	-	-	-	-	-
	1200	CFM	227	195	153	71	-	-	-	-
		BHP	0.01	0.02	0.02	0.02	-	-	-	-
		Sones	4.2	3.7	3.6	3.8	-	-	-	-
	1350	CFM	255	228	194	147	65	-	-	-
		BHP	0.02	0.02	0.02	0.03	0.03	-	-	-
		Sones	5.3	5.0	4.8	4.9	5.0	-	-	-
	1500	CFM	284	259	230	196	143	68	-	-
		BHP	0.03	0.03	0.03	0.03	0.04	0.04	-	-
		Sones	6.6	6.3	6.1	5.9	6.1	6.2	-	-
	1650	CFM	308	285	259	231	194	133	68	-
		BHP	0.03	0.04	0.04	0.04	0.05	0.05	0.05	-
		Sones	7.5	7.2	7.0	6.9	6.9	7.0	7.1	-

(1) Models STXD6/STXDe6 and STXD6C/STXDe6C have choke plate.
 Performance certified is for installation type A-free inlet, free outlet. Performance ratings include the effects of birdscreen in the airstream.

The sound ratings shown are loudness values in fan sones @ 5' (1.5m) in a hemispherical free field calculated per AMCA Standard 301. Values shown are for Installation Type A: free inlet hemispherical sone levels.

Speed (RPM) shown is nominal. Performance is based on actual speed of test.

Fan RPM performances may vary from actual current motor offerings for any given model. See Optimizer2 fan selection software for current motor RPM offerings



S&P USA Ventilation Systems, LLC.,
 Div. of Soler & Palau Ventilation Group,
 certifies that the Models STXD shown
 herein are licensed to bear the AMCA
 Seal. The ratings shown are based
 on test and procedures performed in
 accordance with AMCA Publication
 211 and AMCA Publication 311 and
 comply with the requirement of the
 AMCA Certified Ratings Program.



STXD & STXDe:
STANDARD 705 for Electrical
STXD:
STANDARD 762 for Grease Removal



MODEL STXD & STXDe
DIRECT DRIVE CENTRIFUGAL UPBLAST ROOF EXHAUSTER

SIZE 7

Motor HP	RPM		Static Pressure in Inches w.g.						
			0	.125	.25	.375	.5	.625	.75
STXD 1/10 HP 1550 RPM	900	CFM	242	150	-	-	-	-	-
		BHP	0.00	0.01	-	-	-	-	-
		Sones	2.4	1.9	-	-	-	-	-
	1050	CFM	283	209	104	-	-	-	-
		BHP	0.01	0.01	0.01	-	-	-	-
		Sones	3.3	2.7	3.1	-	-	-	-
	1200	CFM	323	261	182	83	-	-	-
		BHP	0.01	0.01	0.02	0.02	-	-	-
		Sones	4.2	3.7	3.8	4.2	-	-	-
	1350	CFM	363	310	244	163	78	-	-
		BHP	0.01	0.02	0.02	0.02	0.02	-	-
		Sones	5.3	4.9	4.8	5.1	5.5	-	-
	1500	CFM	404	356	302	236	155	82	-
		BHP	0.02	0.02	0.03	0.03	0.03	0.03	-
		Sones	6.5	6.1	6.0	6.0	6.3	6.7	-
	1650	CFM	437	394	345	287	223	145	80
		BHP	0.02	0.03	0.03	0.04	0.04	0.04	0.04
		Sones	7.7	7.1	6.9	6.8	7.0	7.3	7.8

Performance certified is for installation type A-free inlet, free outlet. Performance ratings include the effects of birdscreen in the airstream.

The sound ratings shown are loudness values in fan sones @ 5' (1.5m) in a hemispherical free field calculated per AMCA Standard 301. Values shown are for Installation Type A: free inlet hemispherical sone levels.

Speed (RPM) shown is nominal. Performance is based on actual speed of test.

Fan RPM performances may vary from actual current motor offerings for any given model. See Optimizer2 fan selection software for current motor RPM offerings



S&P USA Ventilation Systems, LLC., Div. of Soler & Palau Ventilation Group, certifies that the Models STXD shown herein are licensed to bear the AMCA Seal. The ratings shown are based on test and procedures performed in accordance with AMCA Publication 211 and AMCA Publication 311 and comply with the requirement of the AMCA Certified Ratings Program.



STXD & STXDe:
STANDARD 705 for Electrical
STXD:
STANDARD 762 for Grease Removal



MODEL STXD & STXDe
DIRECT DRIVE CENTRIFUGAL UPBLAST ROOF EXHAUSTER

SIZE 8

Motor HP	RPM		Static Pressure in Inches w.g.								
			0	.125	.25	.375	.5	.625	.75	.875	
STXD 1/25 HP 1050 RPM	700	CFM	379	205	-	-	-	-	-	-	-
		BHP	0.01	0.01	-	-	-	-	-	-	-
		Sones	2.3	1.6	-	-	-	-	-	-	-
	850	CFM	460	342	-	-	-	-	-	-	-
		BHP	0.01	0.02	-	-	-	-	-	-	-
		Sones	3.4	3.1	-	-	-	-	-	-	-
	1000	CFM	542	446	307	-	-	-	-	-	-
		BHP	0.02	0.02	0.03	-	-	-	-	-	-
		Sones	4.9	4.5	3.9	-	-	-	-	-	-
	1150	CFM	612	531	427	-	-	-	-	-	-
		BHP	0.03	0.03	0.04	-	-	-	-	-	-
		Sones	6.6	6.0	5.7	-	-	-	-	-	-
STXDe 1/3 HP 1750 RPM	1200	CFM	680	587	465	302	-	-	-	-	
		BHP	0.03	0.04	0.05	0.04	-	-	-	-	
		Sones	6.6	5.8	5.1	4.8	-	-	-	-	
	1250	CFM	708	620	507	366	-	-	-	-	
		BHP	0.03	0.04	0.05	0.05	-	-	-	-	
		Sones	7.1	6.4	5.5	5.3	-	-	-	-	
	1300	CFM	736	653	550	421	228	-	-	-	
		BHP	0.04	0.05	0.06	0.06	0.05	-	-	-	
		Sones	7.7	6.9	6.1	5.8	5.6	-	-	-	
	1350	CFM	765	686	591	469	299	-	-	-	
		BHP	0.04	0.05	0.06	0.07	0.06	-	-	-	
		Sones	8.3	7.5	6.7	6.3	6.1	-	-	-	
	1400	CFM	793	717	628	512	368	174	-	-	
		BHP	0.05	0.06	0.07	0.08	0.07	0.05	-	-	
		Sones	8.9	8.1	7.3	6.8	6.6	6.5	-	-	
	1450	CFM	821	749	663	554	430	250	-	-	
		BHP	0.05	0.06	0.08	0.08	0.08	0.06	-	-	
		Sones	9.5	8.7	8.0	7.3	7.1	7.0	-	-	
	1500	CFM	850	780	697	594	485	321	-	-	
		BHP	0.06	0.07	0.08	0.09	0.09	0.08	-	-	
		Sones	10.2	9.5	8.6	7.8	7.7	7.5	-	-	
	1550	CFM	878	811	731	637	533	391	216	-	
		BHP	0.06	0.08	0.09	0.10	0.10	0.09	0.07	-	
		Sones	10.8	9.9	9.2	8.2	8.0	7.9	7.8	-	
1600	CFM	906	842	765	680	577	456	291	-		
	BHP	0.07	0.08	0.10	0.11	0.11	0.11	0.09	-		
	Sones	11.2	10.4	9.8	8.7	8.4	8.3	8.2	-		
1650	CFM	877	810	729	636	531	389	213	-		
	BHP	0.06	0.08	0.09	0.10	0.10	0.09	0.07	-		
	Sones	11.7	10.9	10.3	9.3	8.8	8.7	8.6	-		
1700	CFM	904	849	797	736	669	586	443	182		
	BHP	0.09	0.10	0.11	0.12	0.12	0.13	0.12	0.08		
	Sones	10.8	10.5	10.3	9.7	9.2	8.8	8.3	8.0		
1750	CFM	935	881	832	773	712	636	536	312		
	BHP	0.09	0.11	0.12	0.13	0.13	0.14	0.14	0.11		
	Sones	11.4	10.9	10.8	10.2	9.7	9.2	8.8	8.4		



S&P USA Ventilation Systems, LLC., Div. of Soler & Palau Ventilation Group, certifies that the Models STXD shown herein are licensed to bear the AMCA Seal. The ratings shown are based on test and procedures performed in accordance with AMCA Publication 211 and AMCA Publication 311 and comply with the requirement of the AMCA Certified Ratings Program.



STXD & STXDe:
STANDARD 705 for Electrical
STXD:
STANDARD 762 for Grease Removal

Performance certified is for installation type A-free inlet, free outlet. Performance ratings include the effects of birdscreen in the airstream.

The sound ratings shown are loudness values in fan sones @ 5' (1.5m) in a hemispherical free field calculated per AMCA Standard 301. Values shown are for Installation Type A: free inlet hemispherical sone levels.

Speed (RPM) shown is nominal. Performance is based on actual speed of test.

Fan RPM performances may vary from actual current motor offerings for any given model. See Optimizer2 fan selection software for current motor RPM offerings



MODEL STXD & STXDe
DIRECT DRIVE CENTRIFUGAL UPBLAST ROOF EXHAUSTER

SIZE 10

Motor HP	RPM	Static Pressure in Inches w.g.										
		0	.125	.25	.375	.5	.625	.75	.875	1		
STXD 1/4 HP 1075 RPM	700	CFM	587	410	-	-	-	-	-	-	-	-
		BHP	0.02	0.03	-	-	-	-	-	-	-	-
		Sones	3.2	2.4	-	-	-	-	-	-	-	-
	850	CFM	712	575	377	-	-	-	-	-	-	-
		BHP	0.04	0.04	0.05	-	-	-	-	-	-	-
		Sones	4.8	4.1	3.5	-	-	-	-	-	-	-
	1000	CFM	838	726	591	360	-	-	-	-	-	-
		BHP	0.06	0.07	0.08	0.07	-	-	-	-	-	-
		Sones	6.5	5.8	5.4	4.8	-	-	-	-	-	-
	1150	CFM	979	886	777	657	452	-	-	-	-	-
		BHP	0.09	0.10	0.11	0.12	0.12	-	-	-	-	-
		Sones	8.4	7.7	7.2	6.8	6.3	-	-	-	-	-
STXD 1/3 HP 1625 RPM	1200	CFM	1005	914	810	693	533	-	-	-	-	
		BHP	0.07	0.08	0.09	0.09	0.09	-	-	-	-	
		Sones	7.9	7.5	7.2	6.9	6.7	-	-	-	-	
	1250	CFM	1046	960	861	753	620	355	-	-	-	
		BHP	0.08	0.09	0.10	0.10	0.11	0.10	-	-	-	
		Sones	8.5	8.1	7.8	7.5	7.3	7.1	-	-	-	
	1300	CFM	1088	1006	911	811	691	499	-	-	-	
		BHP	0.09	0.10	0.11	0.12	0.12	0.12	-	-	-	
		Sones	9.1	8.7	8.4	8.1	7.9	7.7	-	-	-	
	1350	CFM	1130	1051	960	866	756	613	324	-	-	
		BHP	0.10	0.11	0.12	0.13	0.13	0.13	0.12	-	-	
		Sones	9.8	9.4	9.1	8.8	8.5	8.3	8.2	-	-	
	1400	CFM	1172	1096	1010	920	818	697	481	-	-	
		BHP	0.12	0.12	0.13	0.14	0.15	0.15	0.14	-	-	
		Sones	10.5	10.1	9.7	9.4	9.2	9.0	8.8	-	-	
	1450	CFM	1214	1141	1059	972	877	767	609	322	-	
		BHP	0.13	0.13	0.14	0.15	0.16	0.17	0.16	0.14	-	
		Sones	11.2	10.8	10.4	10.2	9.9	9.7	9.5	9.3	-	
1500	CFM	1256	1186	1107	1023	935	834	710	484	-		
	BHP	0.14	0.15	0.16	0.17	0.18	0.18	0.18	0.17	-		
	Sones	11.9	11.5	11.2	10.9	10.7	10.4	10.2	10.0	-		
1550	CFM	1298	1230	1155	1073	991	896	788	620	344		
	BHP	0.16	0.16	0.17	0.18	0.19	0.20	0.20	0.20	0.17		
	Sones	12.4	12.1	11.7	11.4	11.2	11.0	10.8	10.6	10.4		
1600	CFM	1340	1275	1202	1123	1045	955	856	731	507		
	BHP	0.17	0.18	0.19	0.20	0.21	0.22	0.22	0.22	0.21		
	Sones	13.0	12.6	12.2	12.0	11.7	11.5	11.3	11.1	10.9		
1650	CFM	1381	1319	1249	1173	1097	1014	922	815	645		
	BHP	0.19	0.19	0.20	0.22	0.23	0.24	0.24	0.25	0.24		
	Sones	13.6	13.2	12.8	12.5	12.3	12.0	11.8	11.7	11.5		
1700	CFM	1445	1385	1319	1248	1175	1100	1015	922	809		
	BHP	0.22	0.22	0.23	0.24	0.26	0.27	0.27	0.28	0.28		
	Sones	14.2	13.8	13.4	13.1	12.8	12.6	12.4	12.2	12.0		

STXDe
1/3 HP
1750 RPM



S&P USA Ventilation Systems, LLC., Div. of Soler & Palau Ventilation Group, certifies that the Models STXD shown herein are licensed to bear the AMCA Seal. The ratings shown are based on test and procedures performed in accordance with AMCA Publication 211 and AMCA Publication 311 and comply with the requirement of the AMCA Certified Ratings Program.



STXD & STXDe:
STANDARD 705 for Electrical
STXD:
STANDARD 762 for Grease Removal
 Performance certified is for installation type A-free inlet, free outlet. Performance ratings include the effects of birdscreen in the airstream.

The sound ratings shown are loudness values in fan sones @ 5' (1.5m) in a hemispherical free field calculated per AMCA Standard 301. Values shown are for Installation Type A: free inlet hemispherical sone levels.

Speed (RPM) shown is nominal. Performance is based on actual speed of test.

Fan RPM performances may vary from actual current motor offerings for any given model. See Optimizer2 fan selection software for current motor RPM offerings



MODEL STXD & STXDe
DIRECT DRIVE CENTRIFUGAL UPBLAST ROOF EXHAUSTER

SIZE 12

Motor HP	RPM		Static Pressure in Inches w.g.										
			0	.125	.25	.375	.5	.625	.75	.875	1	1.25	
STXD 1/4 HP 1075 RPM	900	CFM	998	833	642	-	-	-	-	-	-	-	-
		BHP	0.05	0.06	0.07	-	-	-	-	-	-	-	-
		Sones	5.7	5.3	5.0	-	-	-	-	-	-	-	-
	950	CFM	1053	897	729	470	-	-	-	-	-	-	-
		BHP	0.06	0.08	0.08	0.08	-	-	-	-	-	-	-
		Sones	6.2	5.9	5.7	5.3	-	-	-	-	-	-	-
	1000	CFM	1109	959	808	601	-	-	-	-	-	-	-
		BHP	0.08	0.09	0.09	0.10	-	-	-	-	-	-	-
		Sones	6.8	6.5	6.3	5.9	-	-	-	-	-	-	-
	1050	CFM	1164	1021	883	697	-	-	-	-	-	-	-
		BHP	0.09	0.10	0.11	0.11	-	-	-	-	-	-	-
		Sones	7.4	7.2	6.9	6.6	-	-	-	-	-	-	-
	1100	CFM	1220	1083	953	782	552	-	-	-	-	-	-
		BHP	0.10	0.11	0.12	0.13	0.13	-	-	-	-	-	-
		Sones	8.1	7.8	7.6	7.3	6.9	-	-	-	-	-	-
	1150	CFM	1284	1155	1031	883	701	-	-	-	-	-	-
		BHP	0.12	0.13	0.14	0.15	0.15	-	-	-	-	-	-
		Sones	8.7	8.5	8.2	7.9	7.6	-	-	-	-	-	-
	STXD 1/2 HP 1625 RPM	1200	CFM	1337	1218	1091	955	795	524	-	-	-	-
			BHP	0.10	0.11	0.12	0.13	0.14	0.13	-	-	-	-
			Sones	8.8	8.5	8.2	7.7	7.5	7.3	-	-	-	-
		1250	CFM	1393	1278	1157	1030	883	681	-	-	-	-
			BHP	0.11	0.12	0.13	0.14	0.15	0.15	-	-	-	-
			Sones	9.5	9.2	8.9	8.4	8.1	7.9	-	-	-	-
1300		CFM	1449	1338	1223	1103	967	806	522	-	-	-	
		BHP	0.12	0.14	0.15	0.16	0.17	0.17	0.16	-	-	-	
		Sones	10.2	9.9	9.6	9.1	8.8	8.6	8.4	-	-	-	
1350		CFM	1505	1397	1288	1174	1047	904	690	-	-	-	
		BHP	0.14	0.15	0.17	0.18	0.19	0.19	0.19	-	-	-	
		Sones	10.9	10.6	10.2	9.9	9.5	9.3	9.0	-	-	-	
1400		CFM	1560	1456	1353	1242	1125	991	828	-	-	-	
		BHP	0.15	0.17	0.18	0.20	0.21	0.21	0.22	-	-	-	
		Sones	11.6	11.3	11.0	10.6	10.2	10.0	9.8	-	-	-	
1450		CFM	1616	1515	1417	1310	1200	1076	936	-	-	-	
		BHP	0.17	0.19	0.20	0.21	0.23	0.23	0.24	-	-	-	
		Sones	12.4	12.1	11.7	11.4	11.0	10.8	10.5	-	-	-	
1500		CFM	1672	1573	1481	1376	1273	1156	1028	863	-	-	
		BHP	0.19	0.20	0.22	0.23	0.25	0.26	0.26	0.26	-	-	
		Sones	13.1	12.8	12.5	12.1	11.8	11.5	11.3	11.1	-	-	
1550		CFM	1727	1632	1543	1442	1343	1234	1114	979	769	-	
		BHP	0.21	0.22	0.24	0.26	0.27	0.28	0.29	0.29	0.29	-	
		Sones	13.8	13.4	13.1	12.7	12.4	12.1	11.9	11.7	11.5	-	
1600	CFM	1783	1690	1605	1508	1412	1310	1197	1075	913	-		
	BHP	0.23	0.25	0.26	0.28	0.29	0.30	0.31	0.32	0.32	-		
	Sones	14.4	14.0	13.7	13.4	13.1	12.7	12.5	12.3	12.1	-		
1650	CFM	1839	1748	1665	1573	1480	1384	1277	1162	1032	-		
	BHP	0.25	0.27	0.29	0.30	0.32	0.33	0.34	0.35	0.35	-		
	Sones	15.0	14.7	14.3	14.0	13.7	13.4	13.1	12.9	12.7	-		
1700	CFM	1918	1831	1751	1665	1574	1485	1387	1282	1168	822		
	BHP	0.28	0.30	0.32	0.34	0.35	0.37	0.38	0.39	0.40	0.39		
	Sones	15.6	15.3	15.0	14.7	14.3	14.0	13.7	13.5	13.3	13.0		

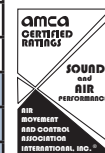

S&P USA Ventilation Systems, LLC., Div. of Soler & Palau Ventilation Group, certifies that the Models STXD shown herein are licensed to bear the AMCA Seal. The ratings shown are based on test and procedures performed in accordance with AMCA Publication 211 and AMCA Publication 311 and comply with the requirement of the AMCA Certified Ratings Program.



STXD & STXDe:
STANDARD 705 for Electrical
STXD:
STANDARD 762 for Grease Removal

Performance certified is for installation type A-free inlet, free outlet. Performance ratings include the effects of birdscreen in the airstream.

The sound ratings shown are loudness values in fan sones @ 5' (1.5m) in a hemispherical free field calculated per AMCA Standard 301. Values shown are for Installation Type A: free inlet hemispherical sone levels.

Speed (RPM) shown is nominal. Performance is based on actual speed of test.

Fan RPM performances may vary from actual current motor offerings for any given model. See Optisizer2 fan selection software for current motor RPM offerings



SIZE 14

Motor HP	RPM		Static Pressure in Inches w.g.											
			0	.125	.25	.375	.5	.625	.75	.875	1	1.25	1.5	
STXD 1/4 HP 1075 RPM	750	CFM	1479	1246	930	-	-	-	-	-	-	-	-	-
		BHP	0.07	0.08	0.09	-	-	-	-	-	-	-	-	-
		Sones	6.4	5.7	5.1	-	-	-	-	-	-	-	-	-
	850	CFM	1677	1481	1240	868	-	-	-	-	-	-	-	-
		BHP	0.10	0.12	0.12	0.12	-	-	-	-	-	-	-	-
		Sones	8.1	7.4	6.7	6.3	-	-	-	-	-	-	-	-
	950	CFM	1874	1702	1500	1244	-	-	-	-	-	-	-	-
		BHP	0.14	0.16	0.17	0.17	-	-	-	-	-	-	-	-
		Sones	10.0	9.3	8.5	8.0	-	-	-	-	-	-	-	-
	1100	CFM	2148	1998	1830	1651	1411	1077	-	-	-	-	-	-
		BHP	0.21	0.23	0.25	0.26	0.26	0.25	-	-	-	-	-	-
		Sones	13.2	12.4	11.7	11.0	10.5	10.2	-	-	-	-	-	-
STXD 3/4 HP 1650 RPM	1,150	CFM	2195	2076	1950	1808	1659	1475	1201	-	-	-	-	-
		BHP	0.25	0.27	0.30	0.32	0.34	0.35	0.34	-	-	-	-	-
		Sones	12.1	11.8	11.5	11.1	10.5	10.0	10.7	-	-	-	-	-
	1,200	CFM	2290	2177	2058	1923	1784	1625	1447	-	-	-	-	-
		BHP	0.29	0.31	0.33	0.36	0.38	0.40	0.40	-	-	-	-	-
		Sones	13.1	12.8	12.5	12.1	11.6	11.1	11.2	-	-	-	-	-
	1,250	CFM	2386	2277	2165	2037	1904	1762	1585	1354	-	-	-	-
		BHP	0.32	0.35	0.37	0.40	0.42	0.44	0.45	0.44	-	-	-	-
		Sones	14.0	13.7	13.5	13.2	12.6	12.2	11.7	12.5	-	-	-	-
	1,300	CFM	2481	2376	2269	2149	2022	1891	1738	1575	-	-	-	-
		BHP	0.36	0.39	0.42	0.44	0.47	0.49	0.51	0.51	-	-	-	-
		Sones	15.1	14.8	14.5	14.2	13.8	13.3	12.8	13.0	-	-	-	-
	1,350	CFM	2576	2476	2373	2260	2139	2015	1879	1712	1524	-	-	-
		BHP	0.41	0.43	0.46	0.49	0.52	0.54	0.56	0.57	0.56	-	-	-
		Sones	16.2	15.9	15.6	15.3	14.9	14.5	14.0	13.6	14.4	-	-	-
	1,400	CFM	2672	2575	2477	2370	2254	2135	2011	1865	1715	-	-	-
		BHP	0.45	0.48	0.51	0.54	0.57	0.59	0.62	0.63	0.63	-	-	-
		Sones	17.2	16.9	16.7	16.4	16.1	15.6	15.2	14.8	15.0	-	-	-
	1,450	CFM	2767	2674	2579	2478	2367	2253	2136	2007	1851	1252	-	-
		BHP	0.50	0.53	0.56	0.59	0.62	0.65	0.68	0.70	0.71	0.63	-	-
		Sones	18.3	18.0	17.7	17.5	17.2	16.8	16.4	16.0	15.6	17.2	-	-
	1,500	CFM	2863	2772	2681	2585	2479	2370	2258	2140	2003	1653	-	-
		BHP	0.56	0.59	0.62	0.65	0.68	0.71	0.74	0.76	0.78	0.77	-	-
		Sones	19.5	19.2	18.9	18.6	18.3	18.0	17.6	17.2	16.9	17.8	-	-
1,550	CFM	2958	2871	2782	2691	2590	2485	2377	2267	2145	1871	-	-	
	BHP	0.62	0.64	0.68	0.71	0.74	0.77	0.80	0.83	0.85	0.86	-	-	
	Sones	20.3	20.0	19.7	19.5	19.2	18.9	18.5	18.1	17.8	18.0	-	-	
1,600	CFM	3054	2969	2883	2796	2700	2598	2495	2390	2279	2008	1481	-	
	BHP	0.68	0.71	0.74	0.77	0.81	0.84	0.87	0.90	0.93	0.95	0.88	-	
	Sones	21.2	21.0	20.7	20.5	20.2	19.9	19.5	19.1	18.7	18.1	19.9	-	
1,650	CFM	3149	3067	2984	2900	2809	2711	2612	2510	2406	2159	1849	-	
	BHP	0.74	0.77	0.81	0.84	0.87	0.91	0.94	0.97	1.00	1.04	1.03	-	
	Sones	22.2	21.9	21.6	21.3	21.1	20.8	20.4	20.0	19.7	18.9	20.0	-	
STXD 1 HP 1725 RPM	1,725	CFM	3426	3352	3272	3188	3099	3002	2899	2794	2686	2448	2125	
		BHP	0.65	0.67	0.69	0.72	0.76	0.79	0.81	0.83	0.86	0.89	0.89	
		Sones	23.9	23.1	22.2	21.5	21.1	20.7	20.4	20.1	19.9	19.3	18.8	



S&P USA Ventilation Systems, LLC., Div. of Soler & Palau Ventilation Group, certifies that the Models STXD shown herein are licensed to bear the AMCA Seal. The ratings shown are based on test and procedures performed in accordance with AMCA Publication 211 and AMCA Publication 311 and comply with the requirement of the AMCA Certified Ratings Program.



STXD & STXDe:
STANDARD 705 for Electrical
STXD:
STANDARD 762 for Grease Removal

Performance certified is for installation type A-free inlet, free outlet. Performance ratings include the effects of birdscreen in the airstream.

The sound ratings shown are loudness values in fan sones @ 5' (1.5m) in a hemispherical free field calculated per AMCA Standard 301. Values shown are for Installation Type A: free inlet hemispherical sone levels.

Speed (RPM) shown is nominal. Performance is based on actual speed of test.

Fan RPM performances may vary from actual current motor offerings for any given model. See Optimizer2 fan selection software for current motor RPM offerings

Numbers shown in **bold font** are only achievable by the SDBDe 1 HP model with EC motor.



SIZE 15 - 1/2 HP

Motor HP	RPM		Static Pressure in Inches w.g.												
			0	.125	.25	.375	.5	.625	.75	.875	1	1.25	1.5	1.75	
STXD 1/2 HP 1140 RPM	750	CFM	1719	1515	1258	800	-	-	-	-	-	-	-	-	-
		BHP	0.08	0.09	0.10	0.10	-	-	-	-	-	-	-	-	-
		Sones	6.8	6.1	5.4	4.8	-	-	-	-	-	-	-	-	-
	800	CFM	1834	1647	1404	1124	-	-	-	-	-	-	-	-	-
		BHP	0.10	0.11	0.12	0.13	-	-	-	-	-	-	-	-	-
		Sones	7.6	7.0	6.2	5.7	-	-	-	-	-	-	-	-	-
	850	CFM	1948	1772	1548	1315	-	-	-	-	-	-	-	-	-
		BHP	0.11	0.13	0.14	0.15	-	-	-	-	-	-	-	-	-
		Sones	8.5	7.9	7.1	6.5	-	-	-	-	-	-	-	-	-
	900	CFM	2063	1895	1691	1484	1194	-	-	-	-	-	-	-	-
		BHP	0.14	0.16	0.17	0.18	0.19	-	-	-	-	-	-	-	-
		Sones	9.4	8.7	8.1	7.4	6.9	-	-	-	-	-	-	-	-
	950	CFM	2178	2016	1833	1634	1398	-	-	-	-	-	-	-	-
		BHP	0.16	0.18	0.19	0.21	0.22	-	-	-	-	-	-	-	-
		Sones	10.3	9.7	9.1	8.4	7.9	-	-	-	-	-	-	-	-
	1000	CFM	2292	2137	1974	1778	1584	1301	-	-	-	-	-	-	-
		BHP	0.19	0.21	0.22	0.24	0.25	0.25	-	-	-	-	-	-	-
		Sones	11.3	10.7	10.1	9.4	8.8	8.4	-	-	-	-	-	-	-
	1050	CFM	2407	2256	2113	1922	1747	1514	-	-	-	-	-	-	-
		BHP	0.22	0.24	0.26	0.27	0.29	0.29	-	-	-	-	-	-	-
		Sones	12.4	11.8	11.2	10.5	9.8	9.4	-	-	-	-	-	-	-
	1100	CFM	2522	2375	2248	2065	1896	1707	1451	-	-	-	-	-	-
		BHP	0.25	0.27	0.29	0.31	0.32	0.33	0.34	-	-	-	-	-	-
		Sones	13.4	12.9	12.3	11.6	11.0	10.4	9.9	-	-	-	-	-	-
1150	CFM	2643	2501	2384	2215	2048	1887	1670	1298	-	-	-	-	-	
	BHP	0.29	0.31	0.33	0.35	0.37	0.38	0.39	0.38	-	-	-	-	-	
	Sones	14.6	14.0	13.5	12.8	12.1	11.5	11.0	10.6	-	-	-	-	-	

Performance certified is for installation type A-free inlet, free outlet.
 Performance ratings do not include the effects of birdscreen in the airstream.
 The sound ratings shown are loudness values in fan sones @ 5' (1.5m) in a hemispherical free field calculated per AMCA Standard 301. Values shown are for Installation Type A-free inlet fan sone levels.

Speed (RPM) shown is nominal. Performance is based on actual speed of test.

Fan RPM performances may vary from actual current motor offerings for any given model. See Optimizer2 fan selection software for current motor RPM offerings



S&P USA Ventilation Systems, LLC.,
 Div. of Soler & Palau Ventilation Group,
 certifies that the Models STXD shown
 herein are licensed to bear the AMCA
 Seal. The ratings shown are based
 on test and procedures performed in
 accordance with AMCA Publication 211
 and AMCA Publication 311 and comply
 with the requirement of the AMCA
 Certified Ratings Program.



STXD & STXDe:
STANDARD 705 for Electrical
STXD:
STANDARD 762 for Grease Removal



MODEL STXD & STXDc
DIRECT DRIVE CENTRIFUGAL UPBLAST ROOF EXHAUSTER

SIZE 15 - 3/4 & 1 HP

Motor HP	RPM		Static Pressure in Inches w.g.											
			0	.125	.25	.375	.5	.625	.75	.875	1	1.25	1.5	1.75
STXD 3/4 HP 1650 RPM	1300	CFM	2658	2554	2452	2347	2226	2085	1938	1790	1578	-	-	-
		BHP	0.30	0.32	0.35	0.37	0.39	0.42	0.44	0.46	0.46	-	-	-
		Sones	15.5	15.0	14.5	14.1	13.6	13.2	12.9	12.5	12.3	-	-	-
	1350	CFM	2760	2660	2562	2462	2351	2220	2078	1943	1790	-	-	-
		BHP	0.34	0.36	0.38	0.41	0.44	0.46	0.48	0.50	0.52	-	-	-
		Sones	16.5	16.0	15.6	15.2	14.7	14.4	14.0	13.6	13.3	-	-	-
	1400	CFM	2862	2766	2671	2575	2473	2352	2218	2082	1947	1410	-	-
		BHP	0.38	0.40	0.42	0.45	0.48	0.50	0.52	0.55	0.57	0.54	-	-
		Sones	17.6	17.1	16.6	16.2	15.8	15.4	15.1	14.7	14.4	13.8	-	-
	1450	CFM	2965	2871	2780	2688	2592	2480	2354	2222	2096	1745	-	-
		BHP	0.42	0.44	0.47	0.49	0.52	0.55	0.57	0.60	0.62	0.63	-	-
		Sones	18.7	18.2	17.8	17.3	16.9	16.5	16.2	15.8	15.5	14.9	-	-
	1500	CFM	3067	2977	2888	2799	2708	2606	2488	2362	2235	1968	-	-
		BHP	0.46	0.49	0.51	0.54	0.57	0.60	0.62	0.65	0.68	0.71	-	-
		Sones	19.8	19.3	18.9	18.5	18.0	17.6	17.3	16.9	16.6	16.0	-	-
	1550	CFM	3169	3082	2996	2910	2823	2729	2618	2499	2375	2127	-	-
		BHP	0.51	0.53	0.56	0.59	0.62	0.65	0.68	0.70	0.73	0.78	-	-
		Sones	20.7	20.3	19.8	19.4	18.9	18.6	18.2	17.9	17.5	16.9	-	-
	1600	CFM	3271	3187	3103	3020	2936	2848	2746	2634	-	-	-	-
		BHP	0.56	0.59	0.61	0.64	0.68	0.71	0.73	0.76	-	-	-	-
		Sones	21.6	21.2	20.7	20.3	19.9	19.5	19.1	18.8	-	-	-	-
	1650	CFM	3374	3291	3210	3130	3049	2965	-	-	-	-	-	-
		BHP	0.61	0.64	0.67	0.70	0.73	0.76	-	-	-	-	-	-
		Sones	22.5	22.1	21.6	21.2	20.8	20.4	-	-	-	-	-	-
STXD 1-1/2 HP 1725 RPM	1750	CFM	3997	3900	3806	3717	3628	3535	3436	3336	3237	3027	2781	2492
		BHP	0.78	0.82	0.86	0.90	0.94	0.97	1.01	1.04	1.08	1.13	1.18	1.21
		Sones	26.2	25.7	25.2	24.7	24.5	24.2	23.8	23.4	23.0	22.3	21.9	21.6

Performance certified is for installation type A-free inlet, free outlet.

Performance ratings do not include the effects of birdscreen in the airstream.

The sound ratings shown are loudness values in fan sones @ 5' (1.5m) in a hemispherical free field calculated per AMCA Standard 301. Values shown are for Installation Type A-free inlet fan sone levels.

Speed (RPM) shown is nominal. Performance is based on actual speed of test.

Fan RPM performances may vary from actual current motor offerings for any given model. See Optimizer2 fan selection software for current motor RPM offerings



S&P USA Ventilation Systems, LLC., Div. of Soler & Palau Ventilation Group, certifies that the Models STXD shown herein are licensed to bear the AMCA Seal. The ratings shown are based on test and procedures performed in accordance with AMCA Publication 211 and AMCA Publication 311 and comply with the requirement of the AMCA Certified Ratings Program.



STXD & STXDc:
STANDARD 705 for Electrical
STXD:
STANDARD 762 for Grease Removal



SIZE 16

Motor HP	RPM		Static Pressure in Inches w.g.											
			0	.125	.25	.375	.5	.625	.75	.875	1	1.25	1.5	1.75
STXD 1/2 HP 1140 RPM	750	CFM	2108	1894	1633	1272	-	-	-	-	-	-	-	-
		BHP	0.11	0.13	0.14	0.14	-	-	-	-	-	-	-	-
		Sones	7.9	7.7	6.7	6.3	-	-	-	-	-	-	-	-
	800	CFM	2248	2048	1815	1515	-	-	-	-	-	-	-	-
		BHP	0.14	0.15	0.17	0.17	-	-	-	-	-	-	-	-
		Sones	8.6	8.4	7.6	7.0	-	-	-	-	-	-	-	-
	850	CFM	2389	2200	1989	1730	1375	-	-	-	-	-	-	-
		BHP	0.16	0.18	0.20	0.20	0.21	-	-	-	-	-	-	-
		Sones	9.4	9.3	8.5	7.6	7.6	-	-	-	-	-	-	-
	900	CFM	2529	2351	2159	1930	1637	-	-	-	-	-	-	-
		BHP	0.20	0.21	0.23	0.24	0.25	-	-	-	-	-	-	-
		Sones	10.1	9.9	9.3	8.5	8.2	-	-	-	-	-	-	-
	950	CFM	2670	2500	2324	2117	1865	1535	-	-	-	-	-	-
		BHP	0.23	0.25	0.27	0.28	0.29	0.29	-	-	-	-	-	-
		Sones	10.9	10.7	10.2	9.3	8.8	8.9	-	-	-	-	-	-
	1000	CFM	2810	2649	2486	2295	2074	1799	-	-	-	-	-	-
		BHP	0.27	0.29	0.31	0.33	0.33	0.34	-	-	-	-	-	-
		Sones	11.8	11.6	11.3	10.3	9.6	9.5	-	-	-	-	-	-
	1050	CFM	2951	2796	2645	2467	2270	2032	1739	-	-	-	-	-
		BHP	0.31	0.33	0.35	0.37	0.38	0.39	0.39	-	-	-	-	-
		Sones	12.7	12.5	12.3	11.4	10.6	10.1	10.3	-	-	-	-	-
	1100	CFM	3091	2944	2800	2636	2455	2245	1994	-	-	-	-	-
		BHP	0.36	0.38	0.40	0.42	0.44	0.44	0.45	-	-	-	-	-
		Sones	13.6	13.5	13.3	12.5	11.7	11.1	11.1	-	-	-	-	-
1150	CFM	3187	3043	2904	2749	2577	2383	2154	1877	-	-	-	-	
	BHP	0.39	0.41	0.44	0.46	0.48	0.48	0.49	0.49	-	-	-	-	
	Sones	14.6	14.4	14.2	13.7	12.9	12.4	12.0	12.2	-	-	-	-	
STXD 1-1/2 HP 1725 RPM	1750	CFM	4781	4687	4591	4494	4396	4295	4192	4084	3973	3737	3489	3175
		BHP	1.20	1.24	1.28	1.32	1.35	1.39	1.42	1.45	1.48	1.55	1.60	1.63
		Sones	29.3	29.3	29.2	29.1	29.1	29.0	28.6	27.8	27.2	25.9	24.7	24.2

Performance certified is for installation type A-free inlet, free outlet.
 Performance ratings do not include the effects of birdscreen in the airstream.
 The sound ratings shown are loudness values in fan sones @ 5' (1.5m) in a hemispherical free field calculated per AMCA Standard 301. Values shown are for Installation Type A-free inlet fan sone levels.

Speed (RPM) shown is nominal. Performance is based on actual speed of test.

Fan RPM performances may vary from actual current motor offerings for any given model. See Optimizer2 fan selection software for current motor RPM offerings



S&P USA Ventilation Systems, LLC.,
 Div. of Soler & Palau Ventilation Group,
 certifies that the Models STXD shown
 herein are licensed to bear the AMCA
 Seal. The ratings shown are based
 on test and procedures performed in
 accordance with AMCA Publication 211
 and AMCA Publication 311 and comply
 with the requirement of the AMCA
 Certified Ratings Program.



STXD & STXDe:
STANDARD 705 for Electrical
STXD:
STANDARD 762 for Grease Removal



CONSTRUCTION/SPECIFICATION CHECKLIST

Housing

- Curb cap with integral deep single piece spun inlet for efficient performance and prevention of leakage into ductwork.
- Lifting lugs for easy and safe placement of the fan on the roof.
- Heavy-gauge aluminum housing and curb cap for strength and rigidity. Curb cap is galvanized steel on all UL 762 units.
- Adjustable motor base for proper belt tension and ease of adjustment.
- Enclosed ventilated motor/drive compartment isolates motor and drives from exhaust air.
- Neoprene isolators for reduction of vibration and sound.
- Quick-Release latches on motor cover for easy access to motor compartment.
- Water-tight conduit tube for easy electrical connection without having to wire through the breather tube.
- NFPA - Model STXB is suitable for National Fire Protection Association installations. Contact factory for required accessories.

Centrifugal Wheel

- All aluminum wheel.
- Backward-inclined for efficiency at higher static pressure.
- Non-overloading for safe operation in ducted systems.
- Curved blades for efficiency and quiet operation.
- Dynamically balanced for smooth operation.

Motors

- Brands are nationally recognized and locally serviced.
- Single speed drip-proof motors are provided on standard models.
- Disconnect switch is standard with single speed open drip-proof and totally enclosed motors.
- Welded motor brackets designed for maximum strength.

Drives

- Sized for minimum 150% of drive horse power.
- Machined cast iron adjustable motor pulleys.
- Adjustable base for belt tensioning.
- Nonstatic oil resistant V-Belts.

Bearings

- 5 year bearing warranty.
- Heavy-duty ball bearing type.
- Air handling with grease fittings.
- Sized for a minimum L50 life in excess of 200,000 hours.

AMCA Seal

- Assures accuracy of Air and Sound Performance.

cULus Label

- cULus 705 Listed Power Roof Ventilator label assures electrical reliability.
- cUL762us Listed for Restaurant Exhaust Appliance available for applications where required.



SIZE 8

Motor HP	RPM		Static Pressure in Inches w.g.									
			0	0.125	0.25	0.375	0.5	0.625	0.75	0.875	1	
1/4	700	CFM	376	201	-	-	-	-	-	-	-	-
		BHP	0.01	0.01	-	-	-	-	-	-	-	-
		Sones	2.1	1.3	-	-	-	-	-	-	-	-
1/4	800	CFM	430	302	-	-	-	-	-	-	-	-
		BHP	0.02	0.02	-	-	-	-	-	-	-	-
		Sones	2.9	2.2	-	-	-	-	-	-	-	-
1/4	900	CFM	483	377	-	-	-	-	-	-	-	-
		BHP	0.02	0.03	-	-	-	-	-	-	-	-
		Sones	3.9	3.0	-	-	-	-	-	-	-	-
1/4	1000	CFM	537	443	301	-	-	-	-	-	-	-
		BHP	0.03	0.03	0.04	-	-	-	-	-	-	-
		Sones	4.7	3.8	3.3	-	-	-	-	-	-	-
1/4	1100	CFM	591	507	400	-	-	-	-	-	-	-
		BHP	0.04	0.04	0.05	-	-	-	-	-	-	-
		Sones	5.6	4.8	4.3	-	-	-	-	-	-	-
1/4	1200	CFM	645	569	482	322	-	-	-	-	-	-
		BHP	0.05	0.06	0.06	0.06	-	-	-	-	-	-
		Sones	6.5	5.8	5.4	5.0	-	-	-	-	-	-
1/4	1300	CFM	698	629	552	445	-	-	-	-	-	-
		BHP	0.06	0.07	0.08	0.08	-	-	-	-	-	-
		Sones	7.5	6.9	6.5	6.1	-	-	-	-	-	-
1/4	1400	CFM	752	687	618	535	402	-	-	-	-	-
		BHP	0.08	0.09	0.09	0.10	0.10	-	-	-	-	-
		Sones	8.7	8.1	7.7	7.3	6.9	-	-	-	-	-
1/4	1500	CFM	806	744	682	612	512	-	-	-	-	-
		BHP	0.10	0.11	0.11	0.12	0.12	-	-	-	-	-
		Sones	10.0	9.5	9.0	8.6	8.2	-	-	-	-	-
1/4	1600	CFM	859	801	745	682	604	500	-	-	-	-
		BHP	0.12	0.13	0.13	0.14	0.15	0.15	-	-	-	-
		Sones	11.0	10.4	10.0	9.5	9.2	8.8	-	-	-	-
1/4	1700	CFM	913	857	807	748	683	595	462	-	-	-
		BHP	0.14	0.15	0.16	0.16	0.17	0.17	0.17	-	-	-
		Sones	12.0	11.5	11.0	10.5	10.2	9.8	9.6	-	-	-
1/4	1800	CFM	967	914	867	812	755	685	595	415	-	-
		BHP	0.17	0.18	0.19	0.19	0.20	0.21	0.21	0.21	0.20	-
		Sones	13.0	12.5	12.0	11.6	11.2	10.9	10.5	10.2	-	-
1/4	1900	CFM	1021	970	926	875	822	763	687	599	-	-
		BHP	0.20	0.21	0.22	0.22	0.23	0.24	0.24	0.24	0.24	-
		Sones	14.1	13.4	13.0	12.6	12.2	11.9	11.6	11.4	-	-
1/3	2000	CFM	1074	1026	983	938	887	835	773	693	601	-
		BHP	0.23	0.24	0.25	0.26	0.27	0.28	0.28	0.28	0.28	0.28
		Sones	15.2	14.4	14.0	13.6	13.3	13.0	12.7	12.5	12.2	-
1/3	2100	CFM	1128	1081	1041	999	951	903	850	785	705	-
		BHP	0.27	0.28	0.29	0.30	0.30	0.31	0.32	0.33	0.33	-
		Sones	16.4	15.7	15.0	14.6	14.3	14.0	13.8	13.6	13.4	-

Power Ratings (BHP) does not include transmission losses.
 Performance certified is for installation type A - free inlet, free outlet.
 Performance ratings do not include the effects of birdscreen in the airstream.
 The sound ratings shown are loudness values in fan sones @ 5' (1.5m) in a hemispherical free field calculated per AMCA Standard 301. Values shown are for: Installation Type A: free inlet hemispherical sone levels.



S&P USA Ventilation Systems, LLC., Div. of Soler & Palau Ventilation Group, certifies that the Models STXB shown herein are licensed to bear the AMCA Seal. The ratings shown are based on test and procedures performed in accordance with AMCA Publication 211 and AMCA Publication 311 and comply with the requirement of the AMCA Certified Ratings Program.



STANDARD 705 for Electrical
STANDARD 762 for Grease Removal



SIZE 10

Motor HP	RPM		Static Pressure in Inches w.g.								
			0	0.125	0.25	0.375	0.5	0.625	0.75	0.875	1
1/4	650	CFM	545	348	-	-	-	-	-	-	-
		BHP	0.01	0.02	-	-	-	-	-	-	-
		Sones	2.6	2.0	-	-	-	-	-	-	-
1/4	750	CFM	629	468	-	-	-	-	-	-	-
		BHP	0.02	0.03	-	-	-	-	-	-	-
		Sones	3.6	2.9	-	-	-	-	-	-	-
1/4	850	CFM	713	575	384	-	-	-	-	-	-
		BHP	0.03	0.04	0.04	-	-	-	-	-	-
		Sones	4.6	3.9	3.6	-	-	-	-	-	-
1/4	950	CFM	797	675	533	-	-	-	-	-	-
		BHP	0.04	0.05	0.05	-	-	-	-	-	-
		Sones	5.5	4.9	4.5	-	-	-	-	-	-
1/4	1050	CFM	881	771	651	488	-	-	-	-	-
		BHP	0.06	0.06	0.07	0.07	-	-	-	-	-
		Sones	6.5	6.0	5.6	5.4	-	-	-	-	-
1/4	1150	CFM	965	864	758	636	-	-	-	-	-
		BHP	0.07	0.08	0.09	0.10	-	-	-	-	-
		Sones	7.6	7.2	6.7	6.5	-	-	-	-	-
1/4	1250	CFM	1049	958	862	757	628	-	-	-	-
		BHP	0.09	0.10	0.11	0.12	0.12	-	-	-	-
		Sones	8.9	8.5	8.0	7.7	7.5	-	-	-	-
1/4	1350	CFM	1132	1050	961	866	762	619	-	-	-
		BHP	0.12	0.13	0.14	0.15	0.15	0.16	-	-	-
		Sones	10.2	9.9	9.4	8.9	8.8	8.7	-	-	-
1/4	1450	CFM	1216	1141	1057	973	881	774	610	-	-
		BHP	0.14	0.16	0.17	0.18	0.19	0.19	0.19	-	-
		Sones	11.7	11.4	10.9	10.4	10.2	10.0	9.9	-	-
1/4	1550	CFM	1300	1230	1151	1076	991	902	797	615	-
		BHP	0.18	0.19	0.20	0.21	0.22	0.23	0.24	0.23	-
		Sones	13.1	12.7	12.3	11.9	11.5	11.3	11.2	11.0	-
1/3	1650	CFM	1384	1319	1245	1174	1098	1018	930	825	638
		BHP	0.21	0.23	0.24	0.25	0.26	0.27	0.28	0.29	0.28
		Sones	14.3	13.9	13.5	13.1	12.6	12.4	12.3	12.1	12.0
1/3	1750	CFM	1468	1407	1338	1270	1201	1126	1050	962	860
		BHP	0.25	0.27	0.28	0.29	0.30	0.32	0.33	0.34	0.34
		Sones	15.5	15.1	14.8	14.4	13.9	13.5	13.4	13.3	13.2

Power Ratings (BHP) does not include transmission losses.
 Performance certified is for installation type A - free inlet, free outlet.
 Performance ratings do not include the effects of birdscreen in the airstream.
 The sound ratings shown are loudness values in fan sones @ 5' (1.5m) in a hemispherical free field calculated per AMCA Standard 301. Values shown are for: Installation Type A: free inlet hemispherical sone levels.



S&P USA Ventilation Systems, LLC., Div. of Soler & Palau Ventilation Group, certifies that the Models STXB shown herein are licensed to bear the AMCA Seal. The ratings shown are based on test and procedures performed in accordance with AMCA Publication 211 and AMCA Publication 311 and comply with the requirement of the AMCA Certified Ratings Program.



STANDARD 705 for Electrical STANDARD 762 for Grease Removal



SIZE 12

Motor HP	RPM		Static Pressure in Inches w.g.									
			0	0.125	0.25	0.375	0.5	0.625	0.75	0.875	1	1.25
1/4	800	CFM	884	715	475	-	-	-	-	-	-	-
		BHP	0.03	0.04	0.04	-	-	-	-	-	-	-
		Sones	4.4	3.9	3.4	-	-	-	-	-	-	-
1/4	900	CFM	995	849	666	318	-	-	-	-	-	-
		BHP	0.05	0.06	0.06	0.06	-	-	-	-	-	-
		Sones	5.5	4.9	4.5	4.0	-	-	-	-	-	-
1/4	1000	CFM	1105	972	821	626	-	-	-	-	-	-
		BHP	0.06	0.07	0.08	0.09	-	-	-	-	-	-
		Sones	6.6	6.0	5.6	5.1	-	-	-	-	-	-
1/4	1100	CFM	1216	1092	967	811	595	-	-	-	-	-
		BHP	0.08	0.09	0.11	0.11	0.11	-	-	-	-	-
		Sones	7.7	7.2	6.8	6.5	6.1	-	-	-	-	-
1/4	1200	CFM	1326	1214	1108	969	813	-	-	-	-	-
		BHP	0.11	0.12	0.13	0.14	0.15	-	-	-	-	-
		Sones	8.9	8.5	8.1	7.8	7.4	-	-	-	-	-
1/4	1300	CFM	1437	1333	1235	1115	986	827	-	-	-	-
		BHP	0.14	0.15	0.17	0.18	0.18	0.19	-	-	-	-
		Sones	10.3	9.9	9.5	9.2	8.8	8.5	-	-	-	-
1/4	1400	CFM	1547	1452	1357	1260	1140	1013	854	-	-	-
		BHP	0.17	0.18	0.20	0.22	0.22	0.23	0.24	-	-	-
		Sones	11.8	11.4	11.0	10.7	10.4	10.0	9.6	-	-	-
1/3	1500	CFM	1658	1569	1477	1396	1285	1177	1050	896	-	-
		BHP	0.21	0.22	0.24	0.26	0.27	0.28	0.29	0.29	-	-
		Sones	13.4	13.0	12.6	12.3	12.0	11.7	11.3	10.9	-	-
1/3	1600	CFM	1768	1686	1599	1522	1431	1326	1221	1098	950	-
		BHP	0.25	0.27	0.29	0.31	0.32	0.33	0.34	0.35	0.35	-
		Sones	14.7	14.2	13.8	13.5	13.2	13.0	12.6	12.3	11.9	-
1/2	1700	CFM	1879	1801	1720	1644	1570	1471	1375	1272	1155	822
		BHP	0.30	0.32	0.34	0.36	0.38	0.39	0.40	0.41	0.42	0.41
		Sones	16.0	15.6	15.2	14.8	14.6	14.3	14.0	13.7	13.3	12.7
1/2	1800	CFM	1989	1916	1840	1765	1698	1616	1520	1431	1331	1086
		BHP	0.36	0.38	0.40	0.42	0.44	0.46	0.47	0.48	0.49	0.50
		Sones	17.3	16.9	16.5	16.2	15.9	15.7	15.4	15.2	14.8	14.1

Power Ratings (BHP) does not include transmission losses.
 Performance certified is for installation type A - free inlet, free outlet.
 Performance ratings do not include the effects of birdscreen in the airstream.
 The sound ratings shown are loudness values in fan sones @ 5' (1.5m) in a hemispherical free field calculated per AMCA Standard 301. Values shown are for: Installation Type A: free inlet hemispherical sone levels.



S&P USA Ventilation Systems, LLC., Div. of Soler & Palau Ventilation Group, certifies that the Models STXB shown herein are licensed to bear the AMCA Seal. The ratings shown are based on test and procedures performed in accordance with AMCA Publication 211 and AMCA Publication 311 and comply with the requirement of the AMCA Certified Ratings Program.



STANDARD 705 for Electrical
STANDARD 762 for Grease Removal





MODEL STXB
BELT DRIVE CENTRIFUGAL UPBLAST ROOF EXHAUSTER

SIZE 14

Motor HP	RPM		Static Pressure in Inches w.g.										
			0	0.125	0.25	0.375	0.5	0.625	0.75	0.875	1	1.25	1.5
1/4	550	CFM	1111	808	-	-	-	-	-	-	-	-	-
		BHP	0.03	0.03	-	-	-	-	-	-	-	-	-
		Sones	3.3	2.3	-	-	-	-	-	-	-	-	-
1/4	650	CFM	1313	1081	-	-	-	-	-	-	-	-	
		BHP	0.04	0.05	-	-	-	-	-	-	-	-	
		Sones	4.5	3.7	-	-	-	-	-	-	-	-	
1/4	750	CFM	1515	1324	1062	-	-	-	-	-	-	-	
		BHP	0.06	0.08	0.09	-	-	-	-	-	-	-	
		Sones	6.0	5.4	4.7	-	-	-	-	-	-	-	
1/4	850	CFM	1717	1552	1344	1070	-	-	-	-	-	-	
		BHP	0.09	0.11	0.12	0.13	-	-	-	-	-	-	
		Sones	7.5	6.8	6.0	5.8	-	-	-	-	-	-	
1/4	950	CFM	1920	1775	1607	1392	1049	-	-	-	-	-	
		BHP	0.13	0.15	0.16	0.18	0.18	-	-	-	-	-	
		Sones	8.9	8.2	7.4	6.8	6.9	-	-	-	-	-	
1/4	1050	CFM	2122	1993	1847	1671	1472	-	-	-	-	-	
		BHP	0.17	0.20	0.21	0.23	0.24	-	-	-	-	-	
		Sones	10.3	9.6	9.0	8.5	8.1	-	-	-	-	-	
1/3	1150	CFM	2324	2208	2077	1934	1758	1573	-	-	-	-	
		BHP	0.23	0.25	0.27	0.29	0.31	0.32	-	-	-	-	
		Sones	11.8	11.3	10.9	10.3	9.8	9.6	-	-	-	-	
1/2	1250	CFM	2526	2421	2303	2178	2030	1865	1691	-	-	-	
		BHP	0.29	0.32	0.34	0.37	0.39	0.40	0.41	-	-	-	
		Sones	13.6	13.2	12.9	12.4	11.8	11.3	11.2	-	-	-	
1/2	1350	CFM	2728	2631	2525	2411	2289	2142	1987	1826	-	-	
		BHP	0.37	0.40	0.42	0.45	0.47	0.49	0.51	0.52	-	-	
		Sones	15.6	15.2	15.0	14.6	13.9	13.4	12.9	12.9	-	-	
3/4	1450	CFM	2930	2841	2743	2639	2530	2408	2267	2123	1975	-	
		BHP	0.46	0.49	0.52	0.54	0.57	0.59	0.61	0.63	0.64	-	
		Sones	17.7	17.3	17.1	16.9	16.3	15.7	15.2	14.6	14.7	-	
3/4	1550	CFM	3132	3049	2960	2863	2763	2658	2537	2405	2269	1947	
		BHP	0.56	0.59	0.62	0.65	0.68	0.71	0.73	0.75	0.77	0.78	
		Sones	19.6	19.4	19.1	18.8	18.4	17.8	17.3	16.8	16.3	16.6	
1	1650	CFM	3334	3256	3174	3085	2991	2897	2795	2676	2551	2298	1856
		BHP	0.68	0.71	0.74	0.77	0.80	0.83	0.86	0.89	0.91	0.94	0.92
		Sones	21.3	21.1	20.8	20.6	20.4	19.8	19.3	18.7	18.1	17.7	18.1

Power Ratings (BHP) does not include transmission losses.
Performance certified is for installation type A - free inlet, free outlet.
Performance ratings do not include the effects of birdscreen in the airstream.
The sound ratings shown are loudness values in fan sones @ 5' (1.5m) in a hemispherical free field calculated per AMCA Standard 301. Values shown are for: Installation Type A: free inlet hemispherical sone levels.



S&P USA Ventilation Systems, LLC., Div. of Soler & Palau Ventilation Group, certifies that the Models STXB shown herein are licensed to bear the AMCA Seal. The ratings shown are based on test and procedures performed in accordance with AMCA Publication 211 and AMCA Publication 311 and comply with the requirement of the AMCA Certified Ratings Program.



STANDARD 705 for Electrical
STANDARD 762 for Grease Removal



SIZE 15

Motor HP	RPM		Static Pressure in Inches w.g.											
			0	0.125	0.25	0.375	0.5	0.625	0.75	0.875	1	1.25	1.5	1.75
1/4	700	CFM	1612	1394	1126	-	-	-	-	-	-	-	-	-
		BHP	0.06	0.07	0.09	-	-	-	-	-	-	-	-	-
		Sones	5.5	4.8	4.4	-	-	-	-	-	-	-	-	-
1/4	800	CFM	1842	1656	1448	1162	-	-	-	-	-	-	-	
		BHP	0.09	0.11	0.12	0.13	-	-	-	-	-	-	-	
		Sones	6.9	6.3	5.8	5.8	-	-	-	-	-	-	-	
1/4	900	CFM	2072	1910	1729	1524	1249	-	-	-	-	-	-	
		BHP	0.12	0.15	0.16	0.18	0.19	-	-	-	-	-	-	
		Sones	8.3	7.7	7.2	7.0	7.0	-	-	-	-	-	-	
1/4	1000	CFM	2302	2160	1998	1832	1627	1366	-	-	-	-	-	
		BHP	0.17	0.19	0.22	0.24	0.25	0.26	-	-	-	-	-	
		Sones	9.7	9.1	8.6	8.3	8.3	8.3	-	-	-	-	-	
1/3	1100	CFM	2533	2405	2260	2111	1953	1757	1519	-	-	-	-	
		BHP	0.22	0.25	0.28	0.30	0.32	0.34	0.34	-	-	-	-	
		Sones	11.4	10.7	10.2	9.9	9.6	9.7	10.5	-	-	-	-	
1/2	1200	CFM	2763	2648	2517	2382	2244	2091	1907	1694	1147	-	-	
		BHP	0.29	0.32	0.35	0.38	0.40	0.42	0.44	0.44	0.40	-	-	
		Sones	13.2	12.7	12.3	11.9	11.5	11.3	12.3	11.5	11.6	-	-	
3/4	1300	CFM	2993	2888	2770	2646	2519	2391	2244	2073	1876	-	-	
		BHP	0.37	0.40	0.43	0.46	0.49	0.51	0.54	0.56	0.56	-	-	
		Sones	15.2	14.8	14.4	14.0	13.6	13.3	14.1	13.3	13.4	-	-	
3/4	1400	CFM	3223	3126	3019	2905	2788	2671	2549	2410	2252	1850	-	
		BHP	0.46	0.50	0.53	0.56	0.59	0.62	0.65	0.68	0.70	0.70	-	
		Sones	17.4	17.0	16.7	16.3	15.9	15.6	16.4	15.2	15.3	15.5	-	
1	1500	CFM	3453	3363	3266	3160	3052	2943	2833	2718	2588	2279	1750	
		BHP	0.56	0.60	0.64	0.68	0.71	0.74	0.77	0.80	0.83	0.87	0.84	
		Sones	19.8	19.4	19.0	18.6	18.3	18.0	18.5	17.3	17.3	17.5	17.7	
1	1600	CFM	3684	3600	3510	3412	3311	3210	3107	3004	2895	2638	2325	1669
		BHP	0.68	0.73	0.77	0.81	0.84	0.88	0.91	0.94	0.97	1.04	1.05	0.98
		Sones	21.5	21.2	20.9	20.5	20.2	19.8	19.4	19.1	18.7	18.9	19.1	19.3

Power Ratings (BHP) does not include transmission losses.
 Performance certified is for installation type A - free inlet, free outlet.
 Performance ratings do not include the effects of birdscreen in the airstream.
 The sound ratings shown are loudness values in fan sones @ 5' (1.5m) in a hemispherical free field calculated per AMCA Standard 301. Values shown are for: Installation Type A: free inlet hemispherical sone levels.



S&P USA Ventilation Systems, LLC., Div. of Soler & Palau Ventilation Group, certifies that the Models STXB shown herein are licensed to bear the AMCA Seal. The ratings shown are based on test and procedures performed in accordance with AMCA Publication 211 and AMCA Publication 311 and comply with the requirement of the AMCA Certified Ratings Program.



STANDARD 705 for Electrical
STANDARD 762 for Grease Removal



SIZE 15 HIGH PRESSURE

Motor HP	RPM		Static Pressure in Inches w.g.												
			0.25	0.375	0.5	0.625	0.75	0.875	1	1.25	1.5	1.75	2	2.25	2.5
1/4	750	CFM	881	483	-	-	-	-	-	-	-	-	-	-	-
		BHP	0.07	0.07	-	-	-	-	-	-	-	-	-	-	-
		Sones	4.4	4.3	-	-	-	-	-	-	-	-	-	-	-
1/4	850	CFM	1110	908	439	-	-	-	-	-	-	-	-	-	
		BHP	0.10	0.11	0.10	-	-	-	-	-	-	-	-	-	
		Sones	5.9	5.5	5.4	-	-	-	-	-	-	-	-	-	
1/4	950	CFM	1324	1154	960	488	-	-	-	-	-	-	-	-	
		BHP	0.13	0.14	0.15	0.13	-	-	-	-	-	-	-	-	
		Sones	7.4	6.7	6.6	6.4	-	-	-	-	-	-	-	-	
1/4	1050	CFM	1523	1379	1221	1035	606	-	-	-	-	-	-	-	
		BHP	0.16	0.18	0.20	0.20	0.19	-	-	-	-	-	-	-	
		Sones	9.0	8.3	7.8	7.7	7.6	-	-	-	-	-	-	-	
1/4	1150	CFM	1713	1594	1454	1308	1133	767	-	-	-	-	-	-	
		BHP	0.21	0.23	0.25	0.26	0.27	0.25	-	-	-	-	-	-	
		Sones	10.6	9.9	9.3	8.9	8.8	8.7	-	-	-	-	-	-	
1/3	1250	CFM	1898	1795	1675	1544	1409	1250	952	-	-	-	-	-	
		BHP	0.26	0.28	0.30	0.32	0.33	0.34	0.34	-	-	-	-	-	
		Sones	12.3	11.6	11.0	10.4	10.2	10.0	10.0	-	-	-	-	-	
1/2	1350	CFM	2079	1987	1886	1768	1647	1521	1377	-	-	-	-	-	
		BHP	0.32	0.34	0.36	0.39	0.41	0.42	0.43	-	-	-	-	-	
		Sones	14.1	13.4	12.9	12.2	11.6	11.5	11.4	-	-	-	-	-	
1/2	1450	CFM	2258	2175	2085	1985	1873	1760	1643	1336	-	-	-	-	
		BHP	0.38	0.41	0.44	0.46	0.48	0.50	0.52	0.54	-	-	-	-	
		Sones	16.0	15.4	14.8	14.2	13.7	13.2	13.0	13.0	-	-	-	-	
3/4	1550	CFM	2436	2359	2278	2191	2092	1987	1881	1652	1276	-	-	-	
		BHP	0.46	0.49	0.52	0.54	0.57	0.59	0.62	0.65	0.65	-	-	-	
		Sones	18.0	17.4	16.8	16.3	15.7	15.1	14.7	14.4	14.4	-	-	-	
3/4	1650	CFM	2612	2540	2466	2388	2303	2208	2109	1907	1677	1238	-	-	
		BHP	0.54	0.58	0.61	0.64	0.66	0.69	0.72	0.76	0.79	0.77	-	-	
		Sones	19.9	19.3	18.8	18.3	17.8	17.3	16.8	16.2	15.8	15.7	-	-	
1	1750	CFM	2787	2720	2651	2579	2503	2420	2330	2142	1947	1709	1235	-	
		BHP	0.64	0.68	0.71	0.75	0.77	0.80	0.83	0.88	0.92	0.94	0.91	-	
		Sones	21.8	21.2	20.7	20.2	19.7	19.3	18.9	18.1	17.6	17.3	17.0	-	
1	1850	CFM	2961	2898	2833	2767	2698	2624	2544	2370	2189	1998	1752	1270	
		BHP	0.75	0.79	0.82	0.86	0.89	0.92	0.95	1.01	1.06	1.10	1.12	1.06	
		Sones	23.7	23.2	22.6	22.1	21.7	21.3	20.9	20.0	19.3	19.0	18.7	18.5	

Power Ratings (BHP) does not include transmission losses.
 Performance certified is for installation type A - free inlet, free outlet.
 Performance ratings do not include the effects of birdscreen in the airstream.
 The sound ratings shown are loudness values in fan sones @ 5' (1.5m) in a hemispherical free field calculated per AMCA Standard 301. Values shown are for: Installation Type A: free inlet hemispherical sone levels.



S&P USA Ventilation Systems, LLC., Div. of Soler & Palau Ventilation Group, certifies that the Models STXB shown herein are licensed to bear the AMCA Seal. The ratings shown are based on test and procedures performed in accordance with AMCA Publication 211 and AMCA Publication 311 and comply with the requirement of the AMCA Certified Ratings Program.



STANDARD 705 for Electrical
STANDARD 762 for Grease Removal



MODEL STXB
BELT DRIVE CENTRIFUGAL UPBLAST ROOF EXHAUSTER

SIZE 16

Motor HP	RPM		Static Pressure in Inches w.g.										
			0	0.125	0.25	0.375	0.5	0.625	0.75	0.875	1	1.25	1.5
1/4	700	CFM	1988	1762	1494	977	-	-	-	-	-	-	-
		BHP	0.09	0.10	0.12	0.12	-	-	-	-	-	-	-
		Sones	6.8	6.3	5.3	4.2	-	-	-	-	-	-	-
1/4	750	CFM	2130	1920	1683	1363	-	-	-	-	-	-	-
		BHP	0.10	0.12	0.14	0.15	-	-	-	-	-	-	-
		Sones	8.0	7.6	6.6	5.3	-	-	-	-	-	-	-
1/4	800	CFM	2272	2076	1863	1596	1006	-	-	-	-	-	-
		BHP	0.13	0.15	0.17	0.18	0.17	-	-	-	-	-	-
		Sones	8.7	8.3	7.5	6.4	5.3	-	-	-	-	-	-
1/4	850	CFM	2414	2231	2035	1801	1495	-	-	-	-	-	-
		BHP	0.15	0.17	0.20	0.22	0.22	-	-	-	-	-	-
		Sones	9.5	9.2	8.4	7.4	6.3	-	-	-	-	-	-
1/4	900	CFM	2555	2383	2201	1992	1740	1208	-	-	-	-	-
		BHP	0.18	0.20	0.23	0.25	0.26	0.24	-	-	-	-	-
		Sones	10.3	9.9	9.3	8.5	7.4	6.5	-	-	-	-	-
1/4	950	CFM	2697	2535	2364	2175	1952	1670	-	-	-	-	-
		BHP	0.21	0.24	0.26	0.29	0.30	0.31	-	-	-	-	-
		Sones	11.2	10.6	10.1	9.3	8.4	7.5	-	-	-	-	-
1/3	1000	CFM	2839	2685	2524	2352	2152	1917	1511	-	-	-	-
		BHP	0.25	0.27	0.30	0.33	0.35	0.36	0.35	-	-	-	-
		Sones	12.1	11.5	10.9	10.2	9.4	8.5	7.8	-	-	-	-
1/2	1050	CFM	2981	2835	2682	2522	2341	2132	1875	-	-	-	-
		BHP	0.29	0.32	0.34	0.37	0.39	0.41	0.42	-	-	-	-
		Sones	13.0	12.5	12.0	11.2	10.4	9.6	8.9	-	-	-	-
1/2	1100	CFM	3123	2984	2839	2688	2523	2335	2121	1822	-	-	-
		BHP	0.33	0.36	0.39	0.42	0.44	0.47	0.48	0.48	-	-	-
		Sones	13.9	13.4	13.0	12.3	11.5	10.8	10.0	9.3	-	-	-
3/4	1150	CFM	3265	3132	2994	2852	2699	2528	2334	2105	1687	-	-
		BHP	0.38	0.41	0.44	0.47	0.50	0.52	0.54	0.55	0.53	-	-
		Sones	14.9	14.4	14.0	13.4	12.8	12.2	11.3	10.6	9.9	-	-
3/4	1200	CFM	3407	3280	3148	3012	2871	2713	2539	2344	2103	-	-
		BHP	0.43	0.46	0.49	0.52	0.56	0.58	0.61	0.62	0.62	-	-
		Sones	15.9	15.5	15.1	14.7	14.1	13.5	12.8	11.9	11.2	-	-
3/4	1250	CFM	3549	3427	3301	3171	3038	2892	2732	2555	2355	-	-
		BHP	0.48	0.52	0.55	0.58	0.62	0.65	0.67	0.69	0.71	-	-
		Sones	17.0	16.8	16.5	16.2	15.5	14.9	14.3	13.4	12.6	-	-
1	1300	CFM	3691	3574	3453	3329	3202	3067	2919	2757	2579	2051	-
		BHP	0.54	0.58	0.61	0.65	0.68	0.72	0.75	0.77	0.79	0.78	-
		Sones	18.4	18.1	17.8	17.5	17.0	16.4	15.8	15.0	14.1	12.6	-
1	1350	CFM	3833	3720	3605	3485	3364	3238	3100	2950	2788	2394	-
		BHP	0.61	0.65	0.68	0.72	0.75	0.79	0.82	0.85	0.87	0.89	-
		Sones	19.8	19.5	19.2	18.9	18.4	17.8	17.3	16.6	15.7	14.0	-
1	1400	CFM	3975	3867	3755	3641	3524	3404	3276	3137	2988	2645	1953
		BHP	0.68	0.72	0.75	0.79	0.83	0.87	0.90	0.93	0.96	0.99	0.93
		Sones	21.1	20.9	20.7	20.4	20.1	19.4	18.8	18.2	17.4	15.7	14.1

Power Ratings (BHP) does not include transmission losses.
Performance certified is for installation type A - free inlet, free outlet.
Performance ratings do not include the effects of birdscreen in the airstream.
The sound ratings shown are loudness values in fan sones @ 5' (1.5m) in a hemispherical free field calculated per AMCA Standard 301. Values shown are for: Installation Type A: free inlet hemispherical sone levels.



S&P USA Ventilation Systems, LLC., Div. of Soler & Palau Ventilation Group, certifies that the Models STXB shown herein are licensed to bear the AMCA Seal. The ratings shown are based on test and procedures performed in accordance with AMCA Publication 211 and AMCA Publication 311 and comply with the requirement of the AMCA Certified Ratings Program.





SIZE 16 HIGH PRESSURE

Motor HP	RPM		Static Pressure in Inches w.g.											
			0.25	0.375	0.5	0.625	0.75	0.875	1	1.25	1.5	1.75	2	2.25
1/4	800	CFM	1294	1054	-	-	-	-	-	-	-	-	-	-
		BHP	0.11	0.12	-	-	-	-	-	-	-	-	-	-
		Sones	6.2	5.7	-	-	-	-	-	-	-	-	-	-
1/4	900	CFM	1560	1362	1140	603	-	-	-	-	-	-	-	
		BHP	0.15	0.16	0.17	0.15	-	-	-	-	-	-	-	
		Sones	7.9	7.4	6.9	6.4	-	-	-	-	-	-	-	
1/4	1000	CFM	1797	1641	1458	1253	804	-	-	-	-	-	-	
		BHP	0.19	0.21	0.23	0.24	0.22	-	-	-	-	-	-	
		Sones	9.4	8.9	8.6	8.1	7.7	-	-	-	-	-	-	
1/3	1100	CFM	2027	1905	1742	1576	1389	1040	-	-	-	-	-	
		BHP	0.24	0.27	0.29	0.31	0.32	0.31	-	-	-	-	-	
		Sones	10.9	10.5	10.2	9.8	9.4	9.0	-	-	-	-	-	
1/2	1200	CFM	2257	2144	2017	1865	1712	1539	1283	-	-	-	-	
		BHP	0.30	0.33	0.36	0.38	0.40	0.41	0.41	-	-	-	-	
		Sones	12.7	12.3	11.9	11.6	11.2	10.8	10.4	-	-	-	-	
1/3	1300	CFM	2483	2374	2272	2143	2003	1861	1700	1119	-	-	-	
		BHP	0.37	0.40	0.43	0.46	0.48	0.50	0.52	0.50	-	-	-	
		Sones	14.4	14.0	13.7	13.4	13.1	12.7	12.3	11.9	-	-	-	
3/4	1400	CFM	2705	2604	2509	2409	2281	2152	2020	1721	995	-	-	
		BHP	0.46	0.49	0.52	0.55	0.58	0.60	0.63	0.65	0.59	-	-	
		Sones	16.6	16.2	15.8	15.4	15.1	14.8	14.5	14.0	13.5	-	-	
1	1500	CFM	2925	2833	2739	2652	2551	2430	2309	2056	1742	944	-	
		BHP	0.55	0.59	0.62	0.66	0.69	0.72	0.74	0.79	0.81	0.70	-	
		Sones	18.8	18.4	18.2	17.8	17.5	17.1	16.8	16.1	15.5	15.2	-	
1	1600	CFM	3142	3058	2969	2886	2802	2702	2588	2361	2109	1775	969	
		BHP	0.66	0.69	0.73	0.77	0.81	0.84	0.87	0.93	0.96	0.98	0.83	
		Sones	20.9	20.5	20.0	19.7	19.4	19.1	18.8	18.3	17.6	17.0	16.6	
1	1700	CFM	3357	3281	3198	3115	3039	2958	2861	2646	2430	2186	1834	1061
		BHP	0.78	0.82	0.86	0.90	0.94	0.98	1.01	1.07	1.13	1.16	1.17	1.01
		Sones	23.1	22.7	22.3	22.0	21.7	21.4	21.1	20.5	19.9	19.1	18.5	18.1

Power Ratings (BHP) does not include transmission losses.
 Performance certified is for installation type A - free inlet, free outlet.
 Performance ratings do not include the effects of birdscreen in the airstream.
 The sound ratings shown are loudness values in fan sones @ 5' (1.5m) in a hemispherical free field calculated per AMCA Standard 301. Values shown are for: Installation Type A: free inlet hemispherical sone levels.



S&P USA Ventilation Systems, LLC., Div. of Soler & Palau Ventilation Group, certifies that the Models STXB shown herein are licensed to bear the AMCA Seal. The ratings shown are based on test and procedures performed in accordance with AMCA Publication 211 and AMCA Publication 311 and comply with the requirement of the AMCA Certified Ratings Program.



STANDARD 705 for Electrical
 STANDARD 762 for Grease Removal

eMotor - Electronically Commutated Motor

S&P's eMotor is 115/230V and 50/60 Hz and is available in 1/3, 1/2, 3/4 and 1 HP. These fully controllable motors offer both reliability and low maintenance in one of the most efficient motor fan combinations in the industry.



Features and Advantages

- Easy speed control by DC 0-10 V variation.
- Motor has motor mounted potentiometer with digital readout for easy speed adjustment.
- Can be controlled by a PC or building management system.
- Motor has 80% usable turndown vs. 30% on a PSC motor.
- Internal motor circuitry converts 115/230 V single phase AC power to DC voltage for increased efficiencies.
- All motors are rated for continuous duty.
- Motor is 115/230V and 50/60 Hz.
- Disconnect is standard.
- Motors ship mounted as standard.

Energy Savings = \$ Savings

STXDe/SDBDe with 1/2 HP Motor - Continuous Ventilation

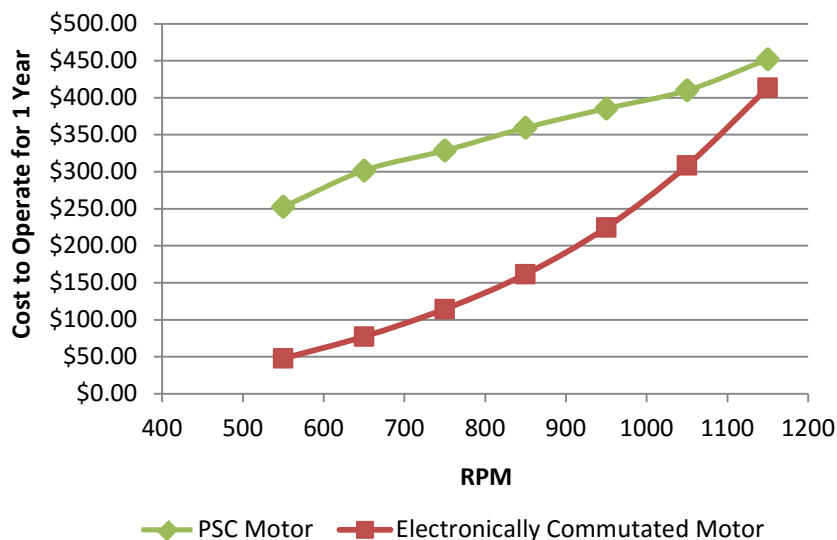

S&P USA Ventilation Systems, LLC **S&P Canada Ventilation Products, Inc.**

6393 Powers Avenue
Jacksonville, FL 32217
P. 904-731-4711 · F. 904-737-8322
www.spvg-northamerica.com

5600 Ambler Drive
Mississauga, ON L4W 2K9 - Canada
Tel. 416-744-1217 · Fax 416-744-0887
www.solerpalaucanada.com

Soler&Palau
Ventilation Group