

Model

**WETS 2000.1301-1.28-ES-S**

OPTIMA® Sensor Activated HET Flushometer and HET Water Closet



**DESCRIPTION**

Complete HET system with exposed, sensor activated, Royal® OPTIMA® Flushometer and vitreous china fixture.

**Flush Cycle**

Model WETS 2000.1301-1.28-ES-S (1.28 gpf/4.8 Lpf)



**SPECIFICATIONS**

Quiet, exposed, sensor activated diaphragm type, chrome plated HET Flushometer for either left or right hand supply and HET vitreous china fixture with the following features:

**Flushometer and OPTIMA® ES-S Unit**

- PERMEX™ Synthetic Rubber Diaphragm with Dual Filtered Fixed Bypass
- OPTIMA® EL-1500-L Self-Adaptive Infrared Sensor with Indicator Light
- User friendly three (3) second Flush Delay
- Courtesy Flush™ Override Button
- Non-Hold-Open Integral Solenoid Operator
- Two (2) Chrome Plated Wall Cover Plates (for 2-gang Electrical Box) with Vandal Resistant Screws
- 1" I.P.S. Screwdriver Bak-Chek™ Angle Stop
- Free Spinning Vandal Resistant Stop Cap
- Adjustable Tailpiece
- High Back Pressure Vacuum Breaker Flush Connection with One-Piece Bottom Hex Coupling Nut, Spud Coupling and Flange for 1 1/2" Top Spud
- Sweat Solder Adapter w/Cover Tube and Cast Wall Flange w/Set Screw
- High Copper, Low Zinc Brass Castings for Dezincification Resistance
- Non-Hold-Open Integral Solenoid Operator, Fixed Metering Bypass and No External Volume Adjustment to Ensure Water Conservation
- Flush Accuracy Controlled by CID™ Technology
- Diaphragm, Stop Seat and Vacuum Breaker to be molded from PERMEX™ Rubber Compound for Chloramine Resistance
- Valve Body, Cover, Tailpiece and Control Stop shall be in conformance with ASTM Alloy Classification for Semi-Red Brass. Valve shall be in compliance to the applicable sections of ASSE 1037.

**Fixture**

- ADA compliant
- Floor mounted vitreous china
- 1 1/2" I.P.S. top spud inlet
- 2 1/8" trapway diameter
- Integral flushing rim
- Elongated bowl with siphon jet flush
- Closet bolts and caps included

**SPECIFICATIONS (CONTINUED)**

- 100 % factory flush tested
- Toilet seat not included  
Compatible with toilet seat models:  
Olsonite 10CT, Bemis 1955CT &  
Church Commercial 295CT
- Water closet shall be in compliance to the applicable sections of ASME A112.19.2/CSA B45.1
- Compliant with Buy American Act when purchased as a combination

**FEATURES**

**Automatic**

Sloan OPTIMA® equipped Flushometers provide the ultimate in sanitary protection and automatic operation. There are no handles to trip or buttons to push. The Flushometer operates by means of an infrared sensor that adapts to its surroundings. Once the user enters the sensor's effective range and then steps away, the Flushometer Solenoid initiates the flushing cycle to flush the fixture.

**Hygienic**

User makes no physical contact with the Flushometer surface. Helps control the spread of infectious diseases. 24-hour Sentinel Flush keeps fixture fresh during periods of nonuse.

**Economical**

Automatic operation provides water usage savings over other flushing devices. Reduces maintenance and operation costs.

**Practical**

Solid state electronic circuitry assures years of dependable, trouble-free operation. The operational components of the Flushometer are identical to a handle activated Royal® Flushometer, proven by more than 100 years of experience.

**Warranty**

3 year (limited)



Listed by I.A.P.M.O.

**NOTE:**

Plumbing System Requirements

- Minimum **Flowing** Pressure: 25 PSI
- Minimum Flow Rate: 18 GPM

<b>This space for Architect/Engineer approval</b>	
Job Name	Date
Model Specified	Quantity
Variations Specified	
Customer/Wholesaler	
Contractor	
Architect	

The information contained in this document is subject to change without notice.

Sloan Valve Company is buying renewable energy certificates to meet 100% of the company's purchased electricity use at its Franklin Park, Illinois facility.

**SLOAN**

Sloan Valve Company  
10500 Seymour Avenue  
Franklin Park, IL 60131  
Phone: 1-800-9-VALVE-9 (982-5839)  
or 1-847-671-4300  
Fax: 1-800-447-8329 or 1-847-671-4380  
www.sloanvalve.com  
Copyright © 2010 Sloan Valve Company  
Rev. 0c (10/10)



**DESCRIPTION**

Complete HET system with exposed, sensor activated, Royal® OPTIMA® Flushometer and vitreous china fixture.

**Flush Cycle**

Model WETS 2000.1301-1.28-ES-S (1.28 gpf/4.8 Lpf)

**ELECTRICAL SPECIFICATIONS**

- **Control Circuit**  
Solid State  
24 VAC Input  
24 VAC Output  
8 Second Arming Delay  
24 Hour Sentinel Flush
- **OPTIMA® Sensor Range**  
Nominal 15" – 30" (381 mm – 762 mm)  
Self-adaptive Window ± 8"(203 mm)
- **Solenoid Operator**  
24 VAC, 50/60 Hz
- **Transformer Accessories**  
EL-154 Transformer (120 VAC/24 VAC 50 VA)  
EL-342 Transformer (240 VAC/24 VAC 50 VA)

**OPERATION**

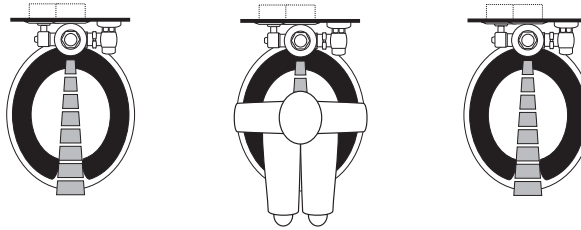

1. A continuous, invisible light beam is emitted from the OPTIMA® Sensor.
2. As the user enters the beam's effective range (15" to 30") the beam is reflected into the OPTIMA® Scanner Window and transformed into a low voltage electrical circuit. Once activated, the Output Circuit continues in a "hold" mode for as long as the user remains within the effective range of the sensor.
3. When the user steps away from the OPTIMA® Sensor, the circuit immediately initiates an electrical "one-time" signal that operates the Solenoid. This initiates the flushing cycle to flush the fixture. The Circuit then automatically resets and is ready for the next user.

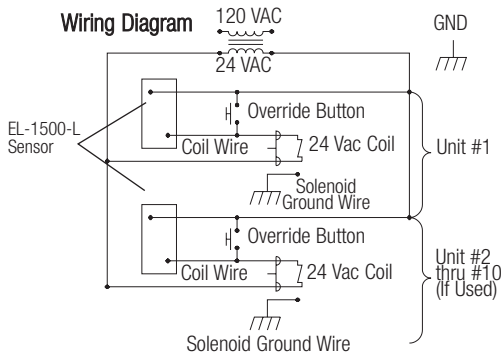

**Electrical Box Installation**

Sensor location and positioning is critical. Failure to properly position the electrical boxes to the plumbing rough-in will result in improper installation and impair product performance. All tradesmen (plumbers, electricians, tile setters, etc.) involved with the installation of this product must coordinate their work to assure proper product installation. Installation template furnished with flushometer.

To ensure a perfect rough-in, Sloan recommends the use of the EL-485-A Flushometer electrical box positioning and support kit. Specify and order the EL-485-A kit separately. Consult factory for installation details.

**DIMENSIONS/ROUGH-IN**

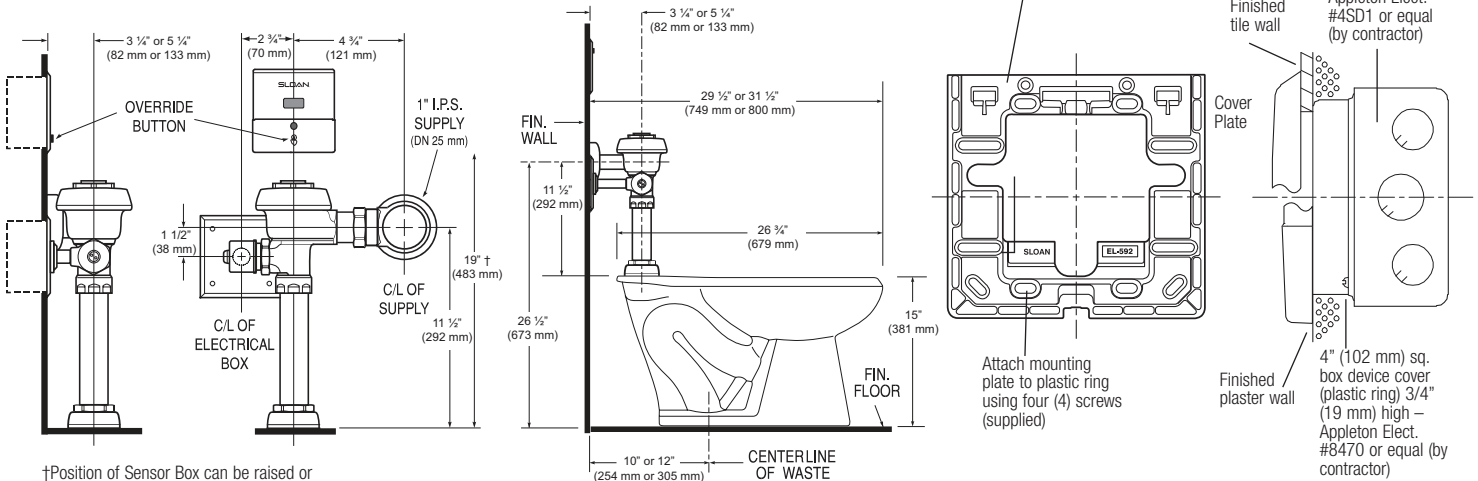

†Position of Sensor Box can be raised or lowered 1" (25 mm) if in conflict with Handicap Grab Bars.

**SLOAN VALVE COMPANY • 10500 SEYMOUR AVENUE • FRANKLIN PARK, IL 60131**

Phone: 1-800-9-VALVE-9 or 1-847-671-4300 • Fax: 1-800-447-8329 or 1-847-671-4380 • www.sloanvalve.com