

INSTALLATION INSTRUCTIONS FOR SLOAN ECOS® DUAL FLUSH ELECTRONIC HARDWIRE FLUSHOMETER AND RETROFIT

Code No. 0816416

Rev.3 (04/17)



Complete Hardwire Flushometer Model

Sloan ECOS® Electronic Hardwire valves are complete Flushometer valves and ideal for new installation.



RESS Series Retrofit Conversion Kit Models

RESS Sloan ECOS® Electronic Hardwire models are used to convert existing Royal and Regal style Flushometers to sensor operation.

Made in the U.S.A.

LIMITED WARRANTY

Sloan Valve Company warrants its Sloan ECOS® Electronic Hardwire Flushometers to be made of first class materials, free from defects of material or workmanship under normal use and to perform the service for which they are intended in a thoroughly reliable and efficient manner when properly installed and serviced, for a period of three years (one year for special finishes) from date of purchase. During this period, Sloan Valve Company will, at its option, repair or replace any part or parts which prove to be thus defective if returned to Sloan Valve Company, at customer's cost, and this shall be the sole remedy available under this warranty. No claims will be allowed for labor, transportation or other incidental costs. This warranty extends only to persons or organizations who purchase Sloan Valve Company's products directly from Sloan Valve Company for purpose of resale.

THERE ARE NO WARRANTIES WHICH EXTEND BEYOND THE DESCRIPTION ON THE FACE HEREOF. IN NO EVENT IS SLOAN VALVE COMPANY RESPONSIBLE FOR ANY CONSEQUENTIAL DAMAGES OF ANY MEASURE WHATSOEVER.

PRIOR TO INSTALLING THE SLOAN ECOS® ELECTRONIC HARDWIRE FLUSHOMETER

Prior to installing the Sloan ECOS® Electronic Hardwire Flushometer, install the items listed below as illustrated in the Rough-in Diagram. (New installations only.)

- Closet fixture
- Drain line
- Water supply line

Important:

- **ALL PLUMBING SHOULD BE INSTALLED IN ACCORDANCE WITH APPLICABLE CODES AND REGULATIONS.**
- **WATER SUPPLY LINES MUST BE SIZED TO PROVIDE AN ADEQUATE VOLUME OF WATER FOR EACH FIXTURE.**
- **WHEN INSTALLING A FLUSHOMETER, IT IS IMPORTANT THAT THE FLUSH MODEL MATCHES THE REQUIREMENTS OF THE PLUMBING FIXTURE.**
- **FLUSH ALL WATER LINES PRIOR TO MAKING CONNECTIONS.**

The Sloan ECOS® Electronic Hardwire designed to operate with 15 PSI to 100 PSI (104 to 689 kPa) of water pressure. THE

MINIMUM PRESSURE REQUIRED TO THE VALVE IS DETERMINED BY THE TYPE OF FIXTURE SELECTED. Consult fixture manufacturer for pressure requirements.

Most Low Consumption water closets (1.6 gpf/6.0 Lpf) require a minimum flowing pressure of 25 PSI (172 kPa).

VAC Power Requirement: Transformer 6 VAC 0.5 mA per unit
Sloan Transformers:

EL-386 – 120 VAC/ 6 VAC Plug-in Transformers

EL-451 – 120 VAC/6 VAC 25 VA Box Style Transformers

Note: One (1) Sloan ECOS® Hardwire per each EL-386 Transformer and six (6) Sloan ECOS® Hardwire per each EL-451 Transformer. 18 gauge wire required.

TOOLS REQUIRED FOR INSTALLATION

- Slotted screwdriver to adjust control stop.
- Sloan A-50 Super-Wrench™, Sloan A-109 Plier Wrench or smooth jawed spud wrench for couplings.
- Trimpot adjustment screwdriver (supplied) to adjust range, if necessary.
- Strap wrench (supplied) to install Sloan ECOS® Electronic Hardwire to the valve body.
- 7/64" hex wrench (supplied) to secure Sloan ECOS® Electronic Hardwire cover to base plate.

VALVE ROUGH-IN

Typical Water Closet Installation

Model 111 - Reference for RESS-C Retrofit

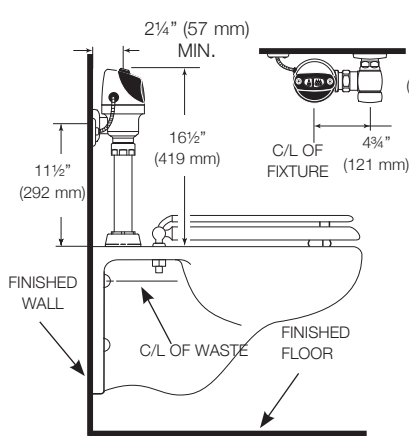

High Rough-in Water Closet Installation

Models 113, 115 & 116

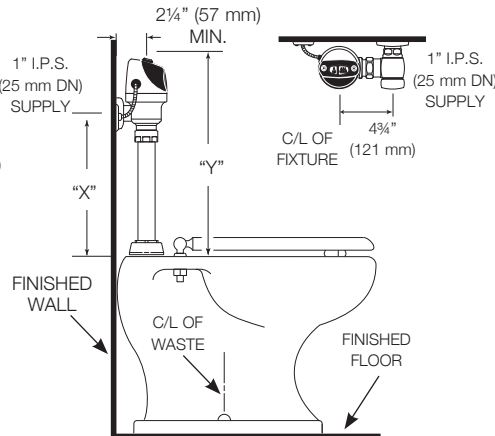

Rough-in Urinal Installation
Models 186 & 180

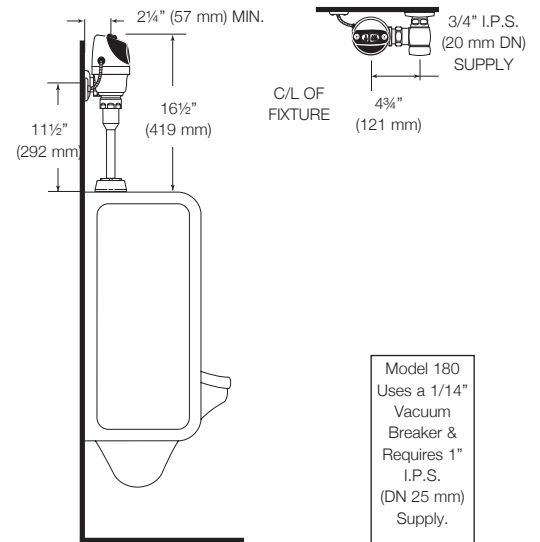

When installing the Sloan ECOS® Electronic Hardwire in a handicap stall:

Per the ADA Guidelines (section 604.9.4) it is recommended that the grab bars be split or shifted to the wide side of the stall.

Squat Toilet Water Closet Installation

Model 137

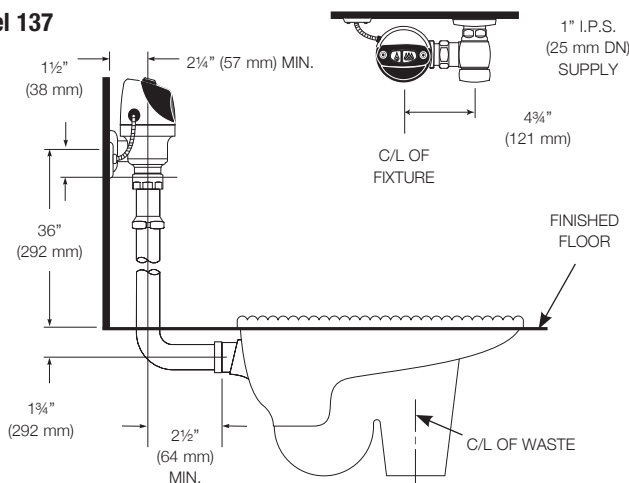

Model 115 & 116 valves are designed for installations where the water supply is roughed-in 24" - 27" (610 mm - 686 mm) above the top of the water closet.

For new installations, Sloan strongly recommends the use of our Model 111 which has a shorter installation height.

Model	"X"	"Y"
113	16" (406 mm)	21" (533 mm)
115	24" (610 mm)	29" (737 mm)
116	27" (686 mm)	32" (813 mm)

Use the Model 113 when toilet seat with covers are being used.

!!! IMPORTANT !!!
Protect the finish of Sloan Flushometers — **DO NOT USE** toothed tools to install or service these valves. Use a Sloan A-50 Super-Wrench™, Sloan A-109 Plier Wrench or smooth jawed spud wrench to secure all couplings. Also see "Care and Cleaning" section of this manual.

!!! IMPORTANT !!!
This product contains mechanical and/or electrical components that are subject to normal wear. These components should be checked on a regular basis and replaced as needed to maintain the valve's performance.

!!! IMPORTANT !!!
The Strap Wrench provided with Sloan ECOS® Electronic Hardwire is a convenience tool and is not to be used to remove or install the Flushometer Couplings. Use Strap Wrench **ONLY** to install Sloan ECOS® Electronic Hardwire Locking Ring.

1 - For Complete Valve Installation Start Here. For RESS Retrofit Installation, Start at Step 6. Install Optional Sweat Solder Adapter (only if your supply pipe does not have a male thread).

- A** Measure from finished wall to C/L of Fixture Spud. Cut pipe 1 1/4" (32 mm) shorter than this measurement. Chamfer O.D. and I.D. of water supply pipe.
- B** Slide Threaded Adapter fully onto pipe.
- C** Sweat solder the Adapter to pipe.

!!! IMPORTANT !!!
With the exception of Control Stop Inlet, **DO NOT** use pipe sealant or plumbing grease on any valve component or coupling!

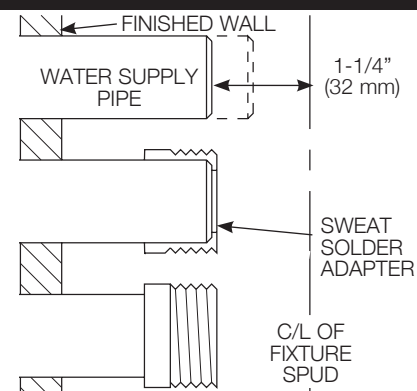

2 - Install Cover Tube, Wall Flange and Control Stop to Supply Pipe

- A** Measure from finished wall to first thread of Adapter or threaded supply pipe (dimension "X"). Cut Cover Tube to this length.
- B** Slide Cover Tube over pipe. Slide Wall Flange over Cover Tube until against wall.
- C** Thread Control Stop onto pipe. Tighten with a wrench.
- D** Tighten Set Screw with a 1/16" hex wrench. **DO NOT** install Vandal Resistant Stop Cap at this time.

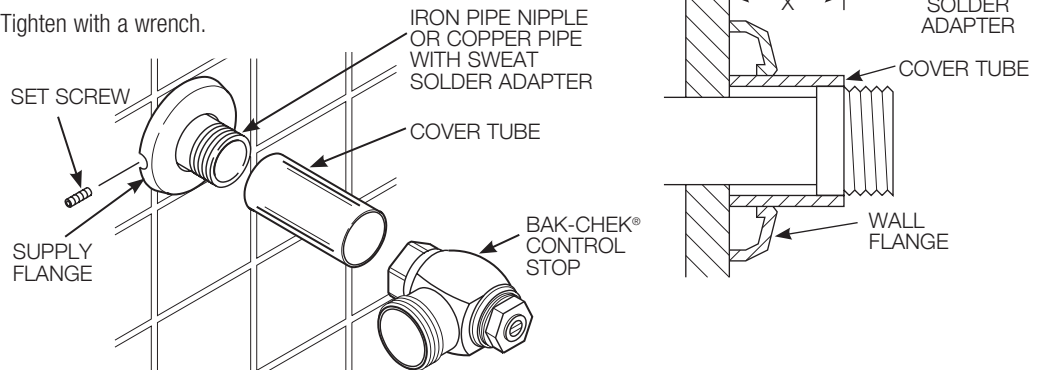

3 - Flush Out Supply Line

- A** Open Control Stop.
- B** Turn on water supply to flush line of any debris or sediment.
- C** Close Control Stop.

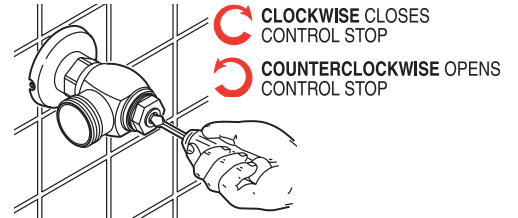

4 - Install Vacuum Breaker Flush Connection

- A** Slide Spud Coupling, Nylon Slip Gasket, Rubber Gasket and Spud Flange over Vacuum Breaker Tube.
- B** Insert Tube into Fixture Spud.
- C** Hand tighten Spud Coupling onto Fixture Spud.

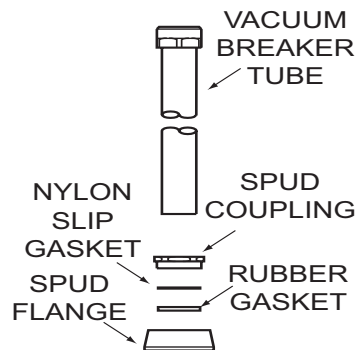

NOTE
If cutting Vacuum Breaker Tube to size, note that Critical Line (C/L) on Vacuum Breaker must typically be 6" (152 mm) above fixture. Consult Code for details.

5 - Install Flushometer

- A** Lubricate tailpiece O-ring with water. Insert Adjustable Tailpiece into Control Stop. Tighten Tailpiece Coupling by hand.
- B** Align Flushometer directly above the Vacuum Breaker Flush Connection by sliding the Flushometer Body IN or OUT as needed. Tighten Vacuum Breaker Coupling by hand.

NOTE

Maximum adjustment of the Sloan Adjustable Tailpiece is 1/2" (13 mm) IN or OUT from the standard 4-3/4" (121 mm) (centerline of Flushometer to centerline of Control Stop).

If roughing-in measurement exceeds 5-1/4" (133 mm), consult factory for longer tailpiece.

- C** Align Flushometer Body and securely tighten first the Tailpiece Coupling (1), then the Vacuum Breaker Coupling (2), and finally the Spud Coupling (3). Use a wrench to tighten these couplings in the order shown.
- D** Install Chrome Handle Cap with Gasket to handle opening on Flushometer Body. Tighten Chrome Handle Cap securely.

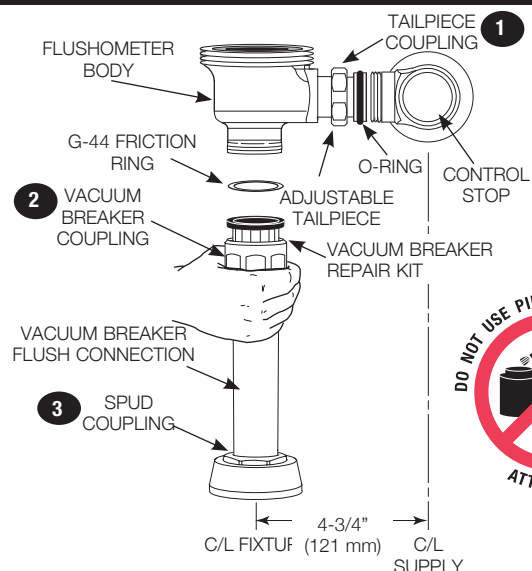

6 - When Retrofitting an Existing Valve, Start Here. Remove Components from Existing Flushometer (RESS Retrofit Installations Only)

- A** Remove Control Stop Cap.
- B** Turn off water supply at Control Stop. Push Valve Handle to relieve water pressure.
- C** Remove Outside and Inside Covers and old Inside Parts Kit.
- D** Remove old Handle Assembly and Gasket.
- E** Install Chrome Handle Cap with Gasket to handle opening on Flushometer Body. Tighten Chrome Handle Cap securely.

NOTE: An extra H-533 Tail O-ring is included in the event leakage occurs if the valve is repositioned during the installation of the new Sloan ECOS® Electronic Hardwire. Use only as needed.

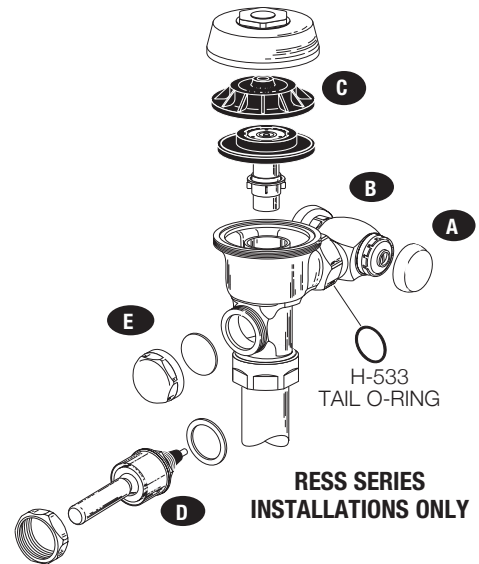

7 - Sloan ECOS® Electronic Hardwire Flush Volume (RESS Retrofit Installations Only)

The Flush Volume of the Sloan ECOS® Electronic Hardwire is controlled by the Flex Tube Diaphragm Kit. Regulators are identified by their color.

RESS-C Sloan ECOS® Electronic Hardwire valves are supplied with its lowest flush volume configuration. When installing a new Regulator on a Flex Tube Diaphragm Kit, be sure to push the Regulator past the O-ring when installing.

Note: Never use more water than needed. Low Consumption water closets will not function properly on excess water.

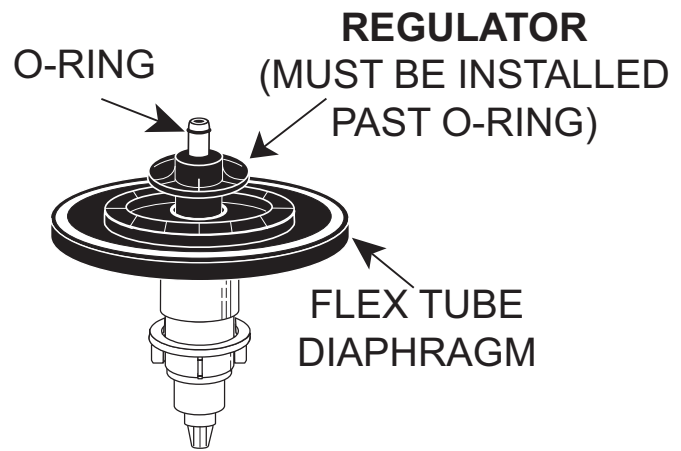

8 - Assemble Flex Tube Diaphragm to Sloan ECOS® Electronic Hardwire Assembly

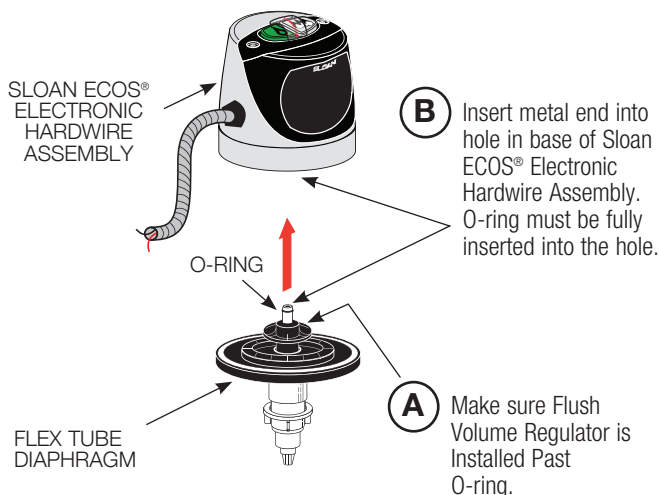

- C** Push Diaphragm securely against underside of Sloan ECOS® Electronic Assembly. Place entire Assembly onto the Valve Body.

To facilitate installation, the O-ring on the diaphragm assembly must be wet for easier insertion.

NOTE: Sensor Lens must face directly forward. Rotating the Sensor to either side will decrease the Sensor's ability to detect a target.

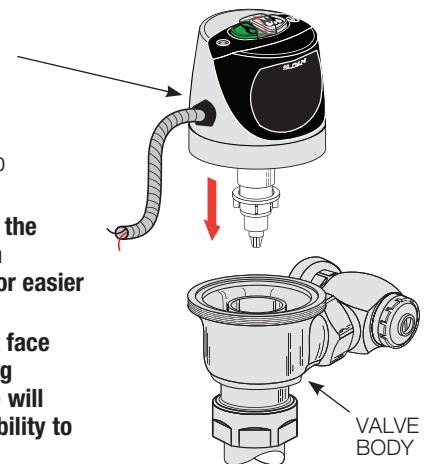

9 - Electrical Supply Flange Installation

A Suggested Mounting Location of Electrical Supply Flange.

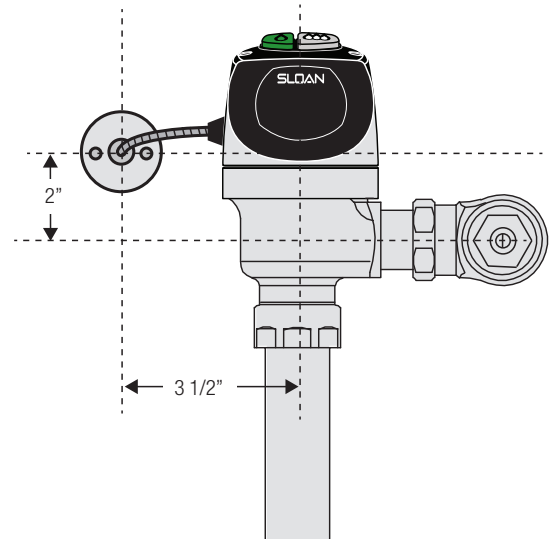

B Drill two (2) mounting holes into wall and mount flange using the appropriate fasteners for the particular wall type.

MOUNTING FASTENERS PROVIDED:

- Plastic Wall Anchor-1/4" (6 mm) hole
- Hollow Wall Anchor-5/16" (8 mm) hole
- Toggle Nut Anchor-1/2" (13 mm) hole

Drill 1/2" (13 mm) center hole. Run cable through center hole in flange.

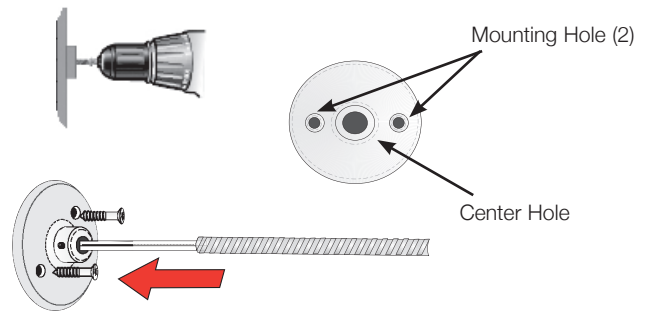

C Insert wires into wire connectors as shown. Twist wire connectors onto wires. Note: Since this is "AC" power there are no polarity concerns with the wire connections.

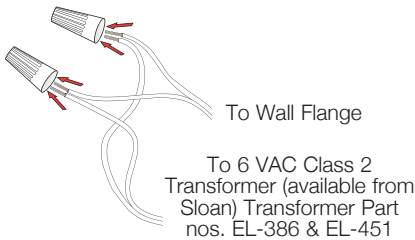

D Tighten setscrew against armor sheath with 1/8" hex wrench.

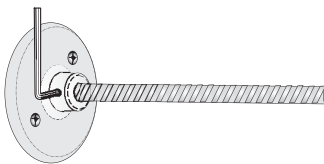

Wiring Diagram

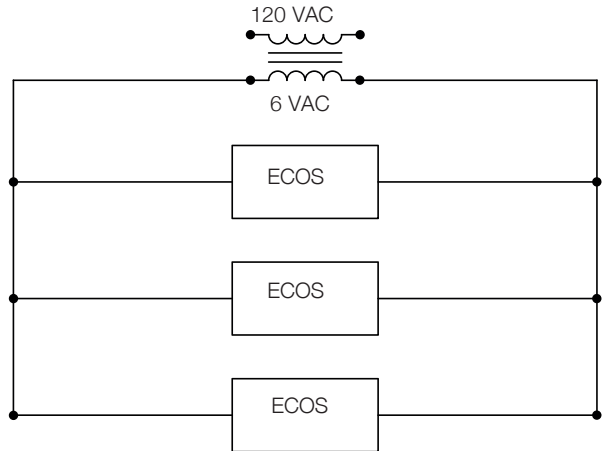

One EL-386 Transformer serves one (1) Optima Closet/Urinal Flushometer. One EL-451 Transformer serves up to six (6) Optima Closet/Urinal Flushometers. 18 gauge wire (not supplied) required from transformer to flushometers.

10 - Tighten Locking Pin and Remove Tab to Activate Sensor

- A** Thread Locking Ring onto Valve Body.
- B** Use Strap Wrench provided to tightly secure Locking Ring.

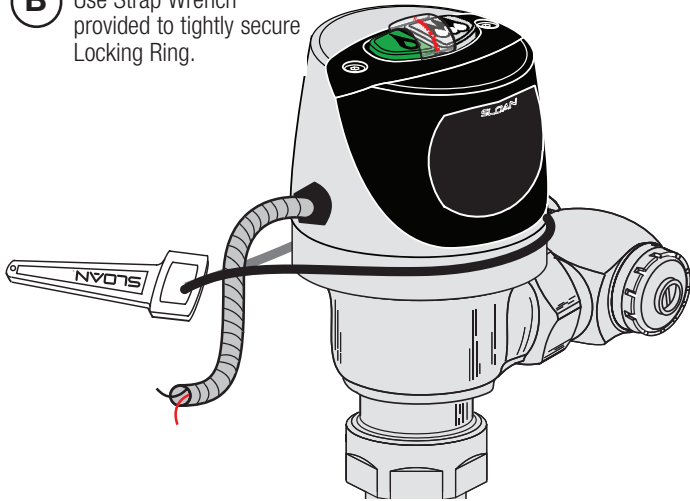

Important: The Locking Ring must be installed down past the valve body threads by at least one thread. If difficulty is experienced installing the Locking Ring, turn the Locking Ring back and forth, each time working it further down the threads. The Locking Ring will act as a thread chaser in the event there has been a build-up of matter on the threads of the old valve body.

- C** Remove the Tab located over the Override Button to activate the Sensor Module.

- D** For the first ten (10) minutes of operation, a Visible Light flashes in the Sensing Window of the Sloan ECOS® Electronic Hardwire Flushometer when a user is detected.

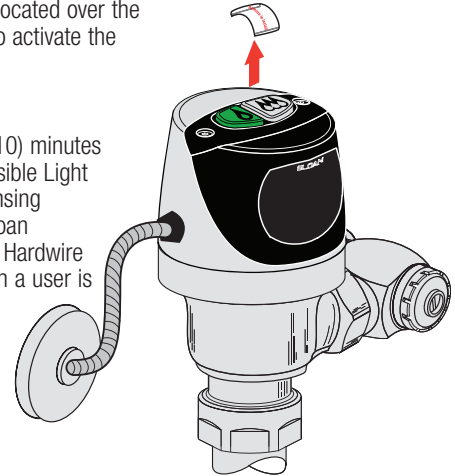

11 - Test Sensor Operation

The Sloan ECOS® Electronic Hardwire has a factory set sensing range: Water Closet Models - 22" to 42" (559 mm to 1067 mm)

- A** Test Sensor with Cover in Place.
- B** Stand in front of Sensor for ten (10) seconds.

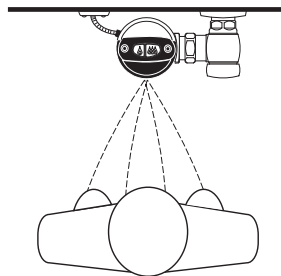

- C** Step away from Sensor and listen for "CLICK."

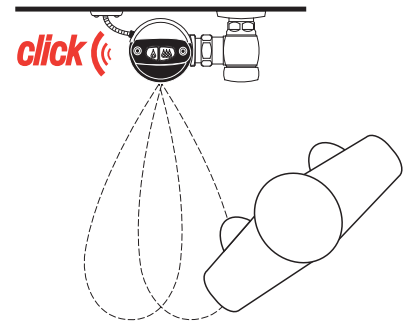

The Factory setting should be satisfactory for most installations. If a range adjustment is required, refer to the Range Adjustment instructions on the next page.

12 - Adjust Control Stop and Install Vandal Resistant Stop Cap

- A** Open Control Stop COUNTERCLOCKWISE ½ turn from closed position.
- B** Activate Flushometer by placing hand in front of Sloan ECOS® Electronic Sensor Lens for ten (10) seconds (or press override button) and then moving it away.
- C** Adjust Control Stop after each flush until the rate of flow delivered properly cleanses the fixture.

Important: The Sloan ECOS® Flushometer is engineered for quiet operation. Excessive water flow creates noise, while too little water flow may not satisfy the needs of the fixture. Proper adjustment is made when plumbing fixture is cleansed after each flush without splashing water out from the lip AND a quiet flushing cycle is achieved.

Important: The Control Stop should never be opened to the point where the flow from the valve exceeds the flow capability of the fixture. In the event of a valve failure, the fixture must be able to accommodate a continuous flow from the valve.

- D** Install Control Stop Cap onto Control Stop. For RESS-C retrofit applications, reuse Stop Cap from existing valve. In complete valve installations, a new Stop Cap is provided. Follow the instructions packaged with the Free Spinning Vandal Resistant Stop Cap.

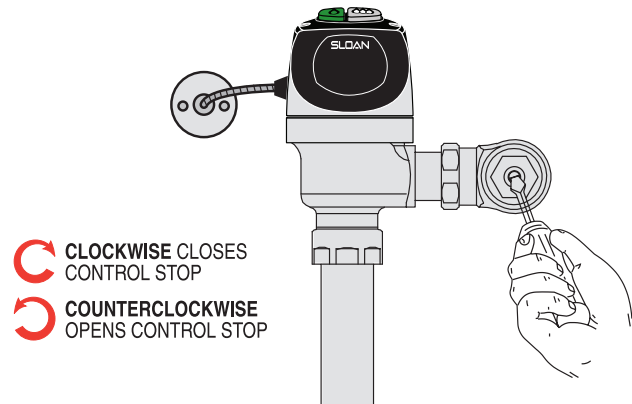

- CLOCKWISE CLOSES CONTROL STOP**
- COUNTERCLOCKWISE OPENS CONTROL STOP**

Operation

1. A continuous, INVISIBLE light beam is emitted from the Sloan ECOS® Electronic Hardwire Sensor.

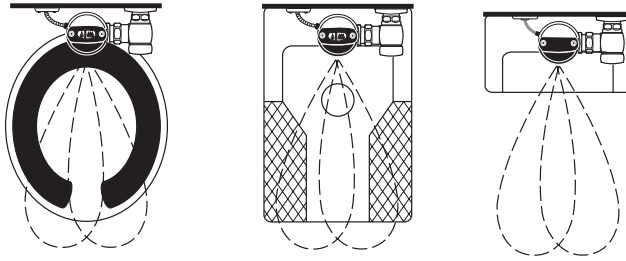

2. As the user enters the beam's effective range, 22" - 42" (559 mm to 1067 mm), the beam is reflected into the Scanner Window to activate the Output Circuit. Once activated, the Output Circuit continues in a "hold" mode for as long as the user remains within the effective range of the sensor. For Dual Flush model, if the user stays longer than 65 seconds, a full flush will automatically initiate when the user leaves.

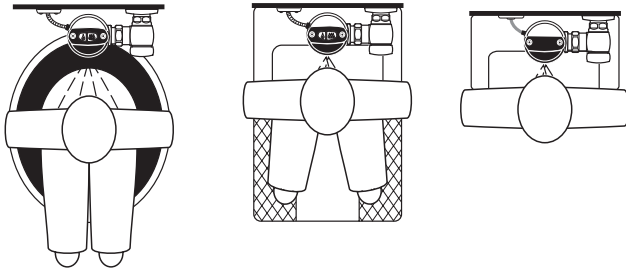

3. For Dual Flush model, once a user is detected, if the user leaves in 65 seconds or less, a reduced flush will automatically initiate. The circuit automatically resets and is ready for the next user.

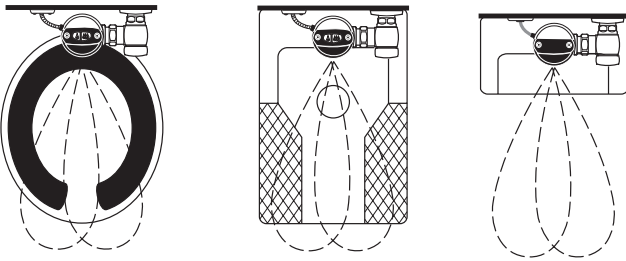

Range Adjustment (Adjust Only if Necessary)

The Sloan ECOS® Electronic Hardwire has a factory set sensing range: Water Closet Models - 22" to 42" (559 mm to 1067 mm), Urinal Models - 15" to 30" (381 mm to 762 mm). **The Factory setting should be satisfactory for most installations.**

If the range is too short (i.e., not picking up users) or too long (i.e., picking up opposite wall or stall door) the range can be adjusted.

Note: Water does not have to be turned off to adjust range. Refer to Illustration.

Loosen the two Screws on top of the unit. Remove the Override Button. Remove the Rubber Plug from top of Electronic Sensor Module to uncover the Potentiometer.

RANGE ADJUSTMENT PROCEDURE

For the first ten (10) minutes of operation, a Visible Light flashes in the Sensing Window of the Sloan ECOS® Electronic Hardwire Flushometer when a user is detected. This Visible Light feature can be reactivated after ten (10) minutes by turning the power off and on. Check the range by stepping toward the unit until the Light flashes, indicating the Sensor's maximum detection limit. Adjust the Range Potentiometer Screw located on top of the Sensor Module a few degrees CLOCKWISE to increase the range or a few degrees COUNTER-CLOCKWISE to decrease the range. Repeat this adjustment until the desired range is achieved.

Always Determine the Sensing Range with Metal Cover and Lens Window On Top of the Unit. Important: Adjust in small increments only! Range Potentiometer Adjustment Screw rotates only ¼ of a turn; DO NOT over-rotate.

When range adjustment is satisfactory, replace the Rubber Plug. Reinstall Override Button and tighten the two Screws on top of the unit.

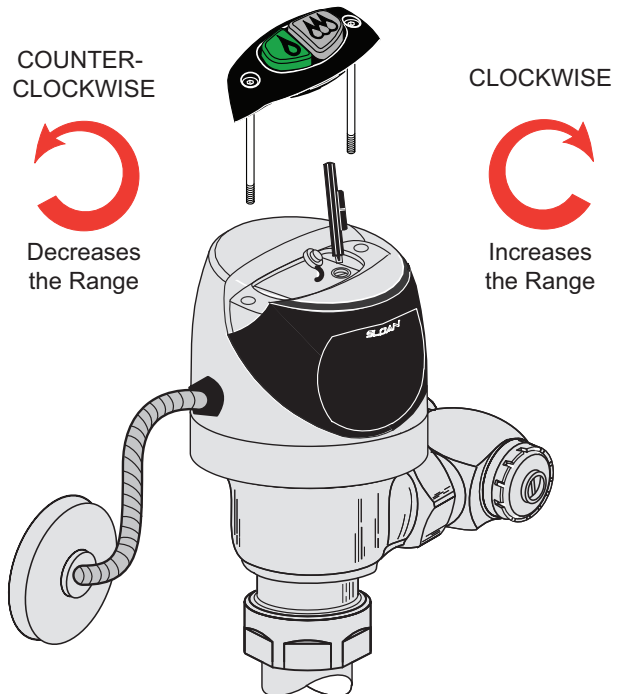

Care and Cleaning of Chrome and Special Finishes

DO NOT use abrasive or chemical cleaners to clean Flushometers as they may dull the luster and attack the chrome or special decorative finishes. Use **ONLY** soap and water, then wipe dry with clean cloth or towel. While cleaning the bathroom tile, the Flushometer should be protected from any splattering of cleaner. Acids and cleaning fluids can discolor or remove chrome plating.

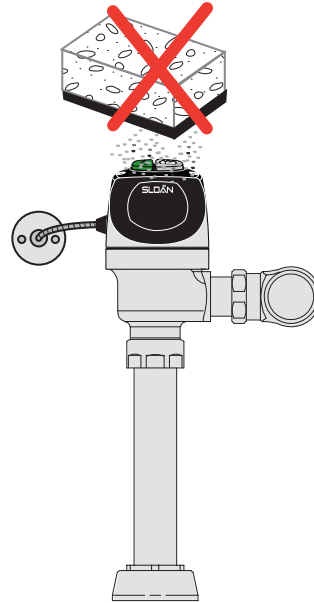

Troubleshooting Guide

1. Sensor Flashes Continuously Only When User Steps Within Range.

A. Unit in Start-Up mode; no problem. This feature is active for the first ten (10) minutes of operation.

2. Valve Does Not Flush; Sensor Does Not Picking Up the User.

A. Range too short; increase the range.

3. Valve Does Not Flush; Sensor Picking Up Opposite Wall or Surface, or Only Flushes When Someone Walks By. Light Flashes Continuously for First 10 Minutes Even with No One in Front of the Sensor.

A. Range too long; shorten the range.

4. Valve Does Not Flush Even After Adjustment.

A. Range Adjustment Potentiometer set at full "max" or full "min" setting. Readjust Potentiometer away from full "max" or "min" setting.

B. Problem with the Electronic Sensor Module; replace the Electronic Sensor Module.

5. Valve Does Not Shut Off.

A. Bypass Orifice in Diaphragm is clogged with dirt or debris, or Bypass is clogged by an invisible gelatinous film due to "over-treated" water. Remove Flex Tube Diaphragm and wash under running water. **Note: Size of Orifice in the Bypass is of utmost importance for the proper metering of water by the valve. DO NOT ENLARGE OR DAMAGE THIS ORIFICE. Replace Flex Tube Diaphragm if cleaning does not correct the problem.**

B. Dirt or debris fouling Stem or Flex Tube Diaphragm. Remove Flex Tube Diaphragm and wash under running water.

C. O-ring on Stem of Flex Tube Diaphragm is damaged or worn. Replace O-ring if necessary.

D. Problem with Electronic Sensor Module; replace Sensor Module.

6. Not Enough Water to the Fixture to Flush Properly.

A. The wrong Flush Volume Regulator was installed in Flex Tube Diaphragm Kit. Install the correct Regulator (see Step 7 of these instructions).

B. Wrong Sloan ECOS® Electronic Hardwire model installed; i.e., 1.6 gpf model installed on 3.5 gallon closet fixture.

C. Enlarged Bypass in Diaphragm. Replace the Flex Tube Diaphragm.

D. Control Stop not adjusted properly. Readjust Control Stop.

E. Inadequate volume or pressure at supply. Increase water pressure or supply (flow) to valve. Consult factory for assistance.

7. Too Much Water to Fixture.

A. The wrong Flush Volume Regulator was installed in Flex Tube Diaphragm Kit. Install the correct Regulator (see Step 7 of these instructions).

B. Control Stop not adjusted properly. Readjust the Control Stop.

C. Wrong Sloan ECOS® Electronic Hardwire model installed; i.e., 3.5 gpf. model installed on 1.6 gallon fixture. Replace with proper Sloan ECOS® Electronic Hardwire model.

D. Dirt in Diaphragm Bypass. Clean under running water or replace Flex Tube Diaphragm.

Note: The EBV-46-A Beam Deflector is no longer required or available for the Sloan ECOS® Electronic Hardwire sensor.

Refer to the Sloan ECOS® Electronic Hardwire Flushometer Maintenance Guide for additional Troubleshooting and Repair Part information available at www.sloanvalve.com.

**If further assistance is required, please contact Sloan Technical Support Department at:
+1.888.SLOAN.14 (+1.888.756.2614)**

Parts List

Item #	Part #	Description
--------	--------	-------------

Items Included with the RESS Retrofit and Complete Sloan ECOS®

Electronic Hardwire Flush Valves

1	††	ECOS® Electronic Hardwire Assembly
2	††	Flex Tube Diaphragm Assembly
3	††	Flush Volume Regulator
4	EL-612-A	Solenoid Wall Flange
5	EBV-137	7/64" Hex Wrench
6	EBV-22	Strap Wrench
7	EBV-91	Range Adjustment Tool
8	WES-19	English Operation Instruction Plate (DF Only)
	WES-22	Spanish Operation Instruction Plate (DF Only)
9	EBV-1017-A	Handle Cap (RESS-C Retrofit Models only)

Items Included with the Complete Sloan ECOS® Electronic Hardwire Flush Valves Only

10	H-700-A	1" (25 mm) Bak-Chek® Control Stop
11	H-1010-A	Vandal Resistant Stop Cap
12	EBV-36-A	Valve Body
13	H-633-AA	1" (25 mm) Sweat Solder Kit
14	V-600-AA	1½" (38 mm) x 10" (254 mm) Vacuum Breaker (Model 110)
	V-600-AA	1½" (38 mm) x 23" (584 mm) Vacuum Breaker (Model 115)
	V-600-AA	1½" (38 mm) x 26" (660 mm) Vacuum Breaker (Model 116)
15	V-600-AA	1¼" (31 mm) x 10" (254 mm) Vacuum Breaker (Model 180)
16	V-600-AA	¾" (19 mm) x 10" (254 mm) Vacuum Breaker (Model 186)
17	F-5-AT	1½" Spud Coupling Assembly (Models 111, 115, and 116)
18	F-5-AT	1¼" Spud Coupling Assembly (Models 180)
19	F-5-AT	¾" Spud Coupling Assembly (Models 186)
20	V-651-A	Vacuum Breaker Assembly

†† Part number varies depending on flushometer model

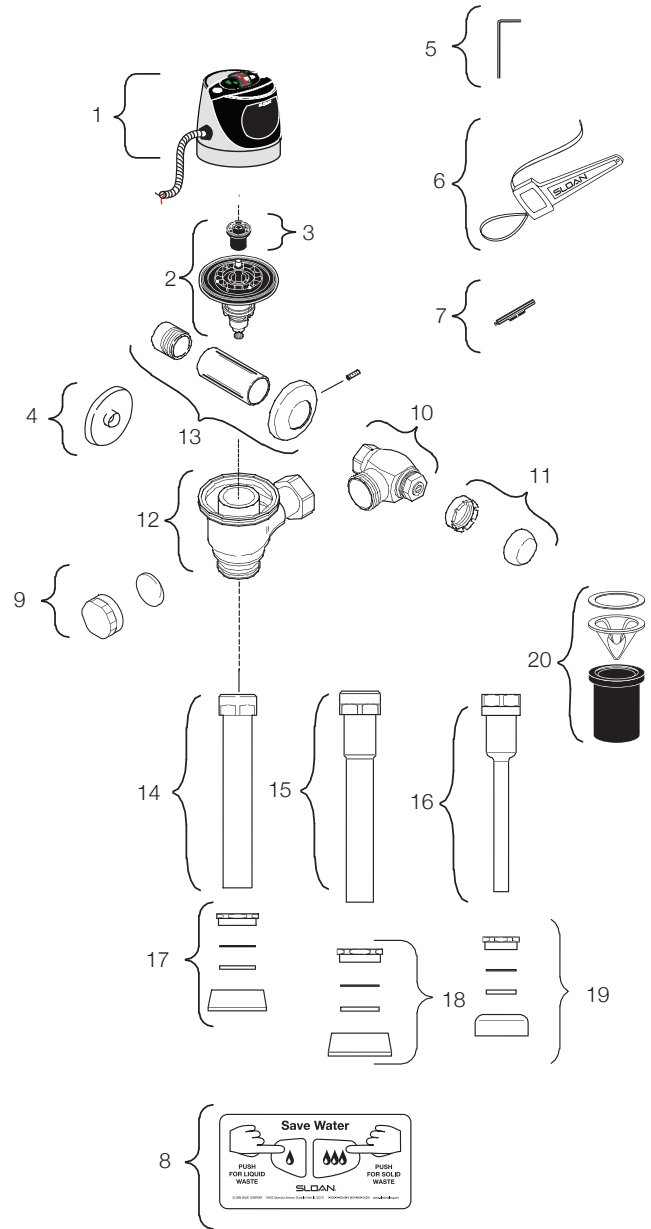

Flex Tube Diaphragm Assembly



Sloan ECOS® Electronic Hardwire Flush Valve Models Feature Sloan's Exclusive Flex Tube Diaphragm™ for the ultimate in valve performance, reliability and chloramines resistance.

Recommended Wall Plate Locations

- Centered over Flushometer
- On stall door.

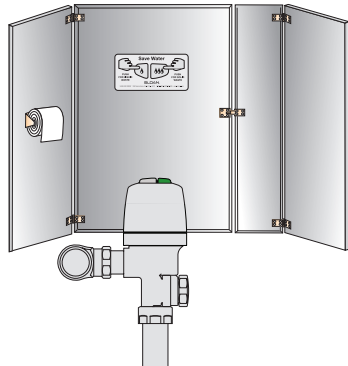
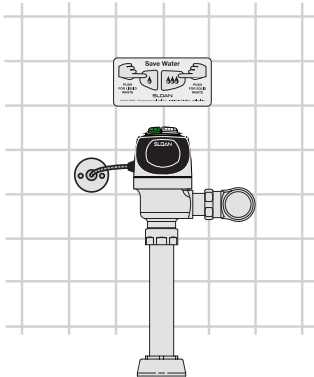

Manufactured in the U.S.A. by Sloan Valve Company under one or more of the following patents: U.S. Patents. 4,839,039; 5,195,720; 5,295,655; 5,542,718; 5,558,120; 5,564,460; 5,887,848; 5,967,182; 6,212,697; 6,382,586; 6,619,614; 6,685,158; 6,691,979; Des. 411,609.

Other Pats. Pending. BAK-CHEK®, CID®, COURTESY FLUSH®, PARA-FLO®, PERMEX®, TURBO-FLO®

SLOAN • 10500 SEYMOUR AVENUE • FRANKLIN PARK, IL 60131

Phone: +1.800.9.VALVE.9 or +1.847.671.4300 • Fax: +1.800.447.8329 or +1.847.671.4380 • www.sloan.com