

## 137 ES-S

► **Description**

Exposed, Sensor Activated Royal<sup>®</sup> Model Water Closet Flushometer, for back inlet squat toilets.

► **Flush Cycle**

- Model 137-1.6 ES-S Low Consumption (1.6 gpf/6.0 Lpf)
- Model 137-2.4 ES-S (2.4 gpf/9.0 Lpf)
- Model 137 ES-S Water Saver (3.5 gpf/13.2 Lpf)

► **Specifications**

Quiet, Exposed, Diaphragm Type, Chrome Plated Closet Flushometer with the following features:

- PERMEX<sup>™</sup> Synthetic Rubber Diaphragm with Dual Filtered Fixed Bypass
- OPTIMA<sup>®</sup> EL-1500-L Self-Adaptive Infrared Sensor with Indicator Light
- User friendly three (3) second Flush Delay
- Courtesy Flush<sup>™</sup> Override Button
- Non-Hold-Open Integral Solenoid Operator
- Die Cast Sensor Plate with no visible Fasteners (for 2-gang Electrical Box)
- Die Cast Solenoid Wall Cover Plate with no visible Fasteners (for 2-gang Electrical Box)
- 1" I.P.S. Screwdriver Bak-Chek<sup>®</sup> Angle Stop (available with 1" Whitworth Thread, please specify)
- Free Spinning Vandal Resistant Stop Cap
- Adjustable Tailpiece
- High Back Pressure Vacuum Breaker Flush Connection with One-Piece Bottom Hex Coupling Nut, Spud Coupling and Flange for 1½" Back Inlet
- Sweat Solder Adapter w/Cover Tube and Cast Wall Flange w/Set Screw
- High Copper, Low Zinc Brass Castings for Dezincification Resistance
- Non-Hold-Open Integral Solenoid Operator, Fixed Metering Bypass and No External Volume Adjustment to Ensure Water Conservation
- Flush Accuracy Controlled by CID<sup>™</sup> Technology
- Diaphragm, Stop Seat and Vacuum Breaker molded from PERMEX<sup>™</sup> Rubber Compound for Chloramine Resistance

Valve Body, Cover, Tailpiece and Control Stop shall be in conformance with ASTM Alloy Classification for Semi-Red Brass. Valve shall be in compliance with the applicable sections of ASSE 1037 and ANSI/ASME A112.19.2. Installation conforms to ADA requirements.

► **Variations**

- U** 1¼" Flush Connection and Spud Coupling
- XYV** Less Vacuum Breaker
- YJ** Split Ring Pipe Support
- YK** Solid Ring Pipe Support

► **Accessories**

- EL-154** Transformer (120 VAC/24 VAC 50 VA)
- EL-342** Transformer (240 VAC/24 VAC 50 VA)
- EL-485-A** Flushometer Electrical Box Positioning and Support Kit

See Accessories Section and OPTIMA Accessories Section of the Sloan catalog for details on these and other OPTIMA Flushometer variations.

Sloan Electronics are:  Listed by I.A.P.M.O.



This space for Architect/Engineer approval	
Job Name _____	Date _____
Model Specified _____	Quantity _____
Variations Specified _____	
Customer/Wholesaler _____	
Contractor _____	
Architect _____	

The information contained in this document is subject to change without notice.



► **Automatic**

Sloan OPTIMA<sup>®</sup> equipped Flushometers provide the ultimate in sanitary protection and automatic operation. There are no handles to trip or buttons to push. The Flushometer operates by means of an infrared sensor that adapts to its surrounding. Once the user enters the sensor's effective range and then steps away, the Flushometer Solenoid initiates the flushing cycle to flush the fixture.

► **Hygienic**

User makes no physical contact with the Flushometer surface except to initiate the Override Button when required. Helps control the spread of infectious diseases. 24-Hour Sentinel Flush keeps fixture fresh during periods of nonuse.

► **Economical**

Automatic operation provides water usage savings over other flushing devices. Reduces maintenance and operation costs.

► **Practical**

Solid state electronic circuitry assures years of dependable, trouble-free operation. The operational components of the Flushometer are identical to a handle activated Royal<sup>®</sup> Flushometer, proven by 90 years of experience.

► **Warranty**

3 year (limited)

► **Made in the U.S.A.**

# 137 ES-S

## ► Description

Exposed, Sensor Activated Royal® Model Water Closet Flushometer, for back inlet squat toilets.

## ► Flush Cycle

- Model 137-1.6 ES-S Low Consumption (1.6 gpf/6.0 Lpf)
- Model 137-2.4 ES-S (2.4 gpf/9.0 Lpf)
- Model 137 ES-S Water Saver (3.5 gpf/13.2 Lpf)

## ELECTRICAL SPECIFICATIONS

### ► Control Circuit

Solid State  
24 VAC Input  
24 VAC Output  
8 Second Arming Delay  
3 Second Flush Delay  
24-Hour Sentinel Flush

### ► OPTIMA Sensor Range

Nominal 22" - 42" (559 mm - 1067 mm)  
Self-adaptive Window ± 10" (254 mm)

### ► Solenoid Operator

24 VAC, 50/60 Hz

### ► Transformer

Sloan Part #EL-154  
120 VAC, 50/60 Hz Primary  
24 VAC, 50/60 Hz Secondary  
Class II, UL Listed, 50 VA.

Sloan Part #EL-342

240 VAC, 50/60 Hz Primary  
24 VAC, 50/60 Hz Secondary  
Class II, UL Listed, 50 VA.

## WIRING DIAGRAM

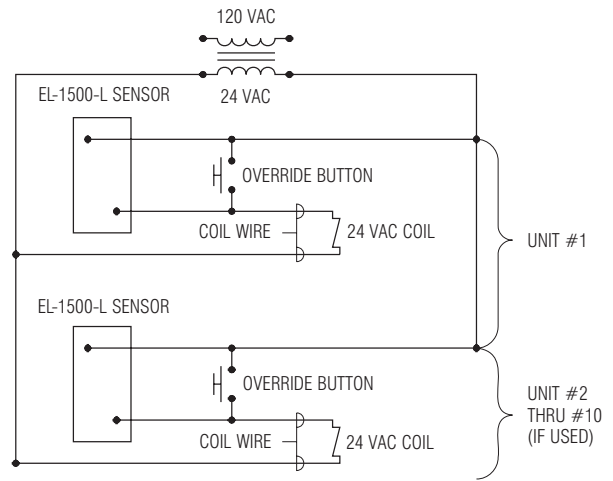

One Transformer serves up to ten (10) OPTIMA Closet/Urinal Flushometers. Specify number of transformers required accordingly.

## OPERATION

1. A continuous, invisible light beam is emitted from the OPTIMA Sensor.

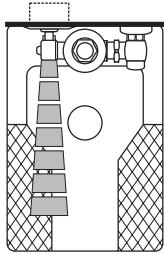

2. As the user enters the beam's effective range (22" to 42") the beam is reflected into the OPTIMA Scanner Window and transformed into a low voltage electrical circuit. Once activated, the Output Circuit continues in a "hold" mode for as long as the user remains within the effective range of the Sensor.

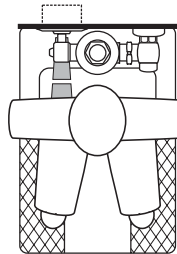

3. When the user steps away from the OPTIMA Sensor, the circuit waits 3 seconds (to prevent false flushing) then initiates an electrical "one-time" signal that operates the Solenoid. This initiates the flushing cycle to flush the fixture. The Circuit then automatically resets and is ready for the next user.

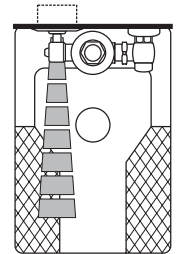

## ROUGH-IN

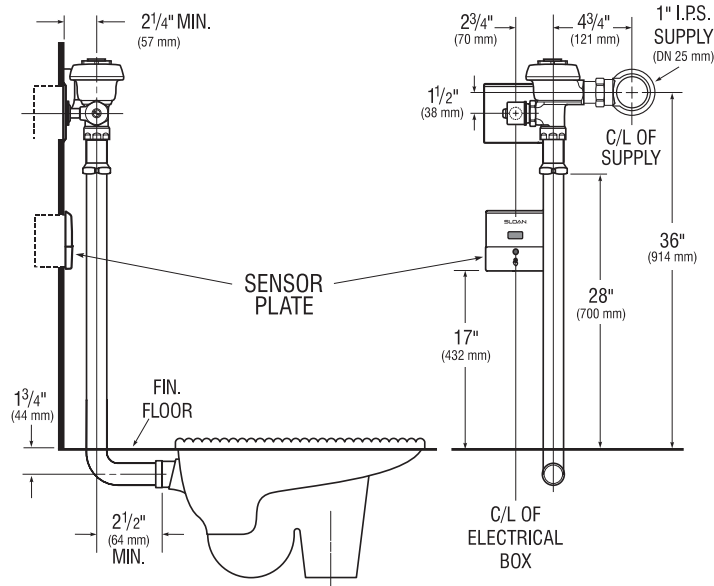

## ELECTRICAL BOX INSTALLATION

### SENSOR LOCATION AND POSITIONING IS CRITICAL

Failure to properly position the electrical boxes to the plumbing rough-in will result in improper installation and impair product performance. All tradesmen (plumbers, electricians, tile setters, etc.) involved with the installation of this product must coordinate their work to assure proper product installation. Installation Template furnished with Flushometer.

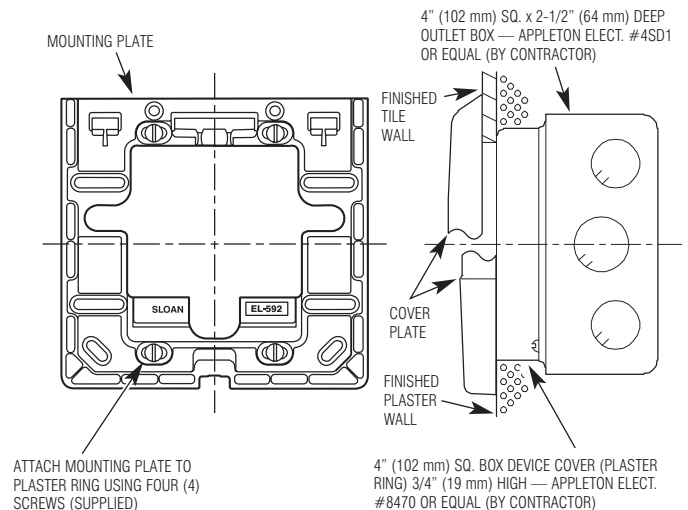

To ensure a perfect rough-in, Sloan recommends the use of the EL-485-A Flushometer Electrical Box Positioning and Support Kit. Specify and order the EL-485-A Kit separately. When using the EL-485-A kit, the Solenoid Plate roughs in at the Urinal location. Consult factory for installation details.

**SLOAN VALVE COMPANY • 10500 SEYMOUR AVENUE • FRANKLIN PARK, IL 60131**

Phone: 1-800-982-5839 or 1-847-671-4300 • Fax: 1-800-447-8329 or 1-847-671-4380 • [www.sloanvalve.com](http://www.sloanvalve.com)