

▶ **Code Number**

1001020

▶ **Description**

Complete Vitreous China Hybrid Urinal with automatic drain rinse.

▶ **Flush Cycle**

Waterfree operation

▶ **Specifications**

- Urinal Assembly
- Complete mounting kit included
- Jetrinse™ Assembly
- Patented housing and drain line rinsing
- Automatic activation injects 1 gallon of water through housing and drain line every 72 hours to prevent struvite build-up and clogs
- IR switch for manual rinse activation
- Long life lithium battery provides at least 8 years of service
- Cartridge Assembly\*
- Enhance patented design maximizes operational life, prevents accidental sealant loss and virtually eliminates odor
- Biodegradable sealant liquid
- Vandal resistant locking design
- 20% less plastic than previous designs
- Provides average of 7,000 uses that saves up to 40,000 gallons of water each year
- \* Replacement cartridges sold separately

▶ **Features**

- Patented drain rinsing assembly
- Minimizes cleaning effort
- Virtually eliminates odor
- Touch-free hygienic operation
- Earns maximum LEED credits
- Up to 5 times cleaner than conventional flush urinals
- Best in class odor control



**IMPORTANT-Do not install on copper DWV due to copper's susceptibility to corrosion.**

▶ **Compliance & Certifications**

IAPMO certified to the applicable requirements in the following standards

ASME A112.19.2./CSA B45.1

ASME A112.1.3



This space for Architect/Engineer Approval

Featuring



### Housing and Jetrinse™ Assembly

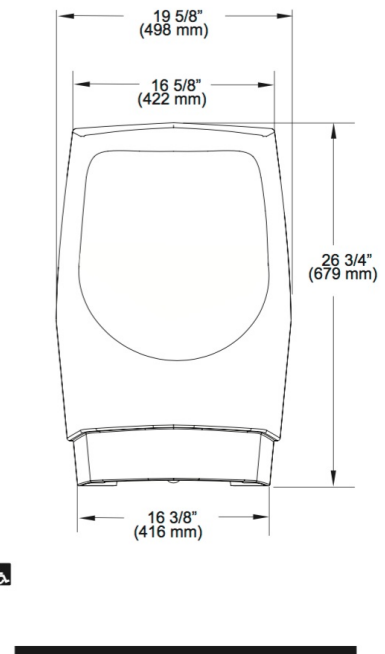
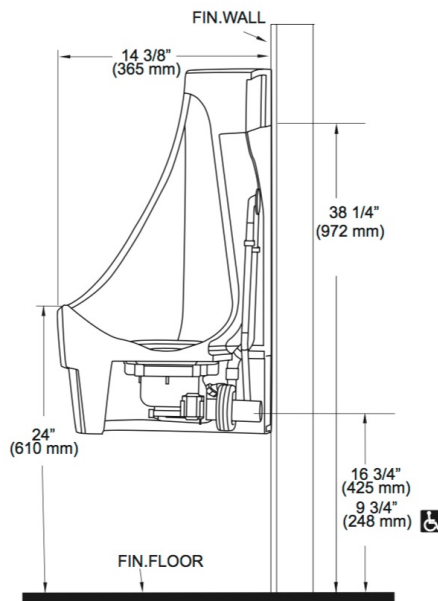
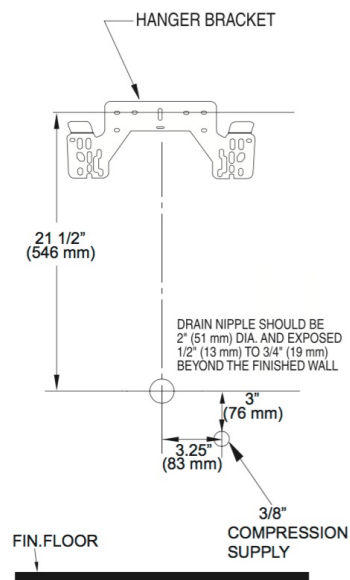
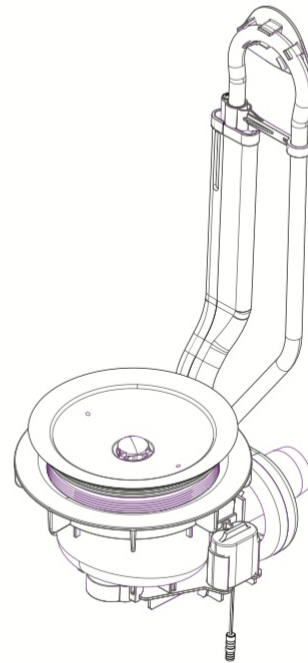

SIDE VIEW

FRONT VIEW

#### ROUGH-IN AND BRACKET LOCATION

NOTE: All vitreous china dimensions shown in these drawings are nominal. Dimensions can vary within the tolerances established in the governing ASME A112.19.2/CSA B45.1 standard. Please take this into consideration when planning rough-in and plumbing layouts.