

**DESCRIPTION**

Complete HEU system with concealed, sensor activated, Royal® OPTIMA® urinal Flushometer and vitreous china urinal fixture.

**Flush Cycle**

Model WEUS 1010.1311-0.125 ES-S (0.125 gpf/0.5 Lpf)



Meets the American Disabilities Guidelines and ANSI A117.1 requirements when installed according to these requirements.



NOTE: Plumbing System Requirements  
√ Minimum **Flowing** Pressure: 25 PSI

**SPECIFICATIONS**

Quiet, concealed, sensor operated diaphragm type, rough brass urinal Flushometer and vitreous china urinal with the following features:

**Flushometer and OPTIMA® ES-S Unit**

- PERMEX® Synthetic Rubber Diaphragm with Dual Filtered Fixed Bypass
- OPTIMA® EL-1500 Self-Adaptive Infrared Sensor with Indicator Light
- Non-Hold-Open Integral Solenoid Operator
- Die Cast Sensor Cover Plate with no visible Fasteners (for 2-gang Electrical Box)
- ¾" I.P.S. Screwdriver Bak-Chek® Angle Stop
- Free Spinning Vandal Resistant Stop Cap
- Adjustable Tailpiece
- High Back Pressure Vacuum Breaker Flush Connection and Spud Coupling for ¾" Concealed Back Spud
- Sweat Solder Adapter
- High copper, low zinc brass castings for dezincification resistance
- Non-Hold-Open Integral Solenoid Operator, Fixed Metering Bypass and no external volume adjustment to ensure water conservation
- Flush accuracy controlled by CID® technology
- Diaphragm, Stop Seat and Vacuum Breaker to be molded from PERMEX® rubber compound for chloramine resistance
- Valve Body, Tailpiece and Control Stop shall be in conformance with ASTM Alloy Classification for Semi-Red Brass. Valve shall be in compliance with the applicable sections of ASSE 1037, ANSI/ASME A112.19.2.

**Fixture**

- Vitreous china
- Wall mounted
- Washdown flushing action
- ¾" rear spud inlet
- 100% factory flush tested
- Integral flushing rim
- All mounting hardware included
- Carrier not included
- Compatible with:  
Jay R. Smith Carrier 0636 or 0637

**FEATURES**

**Automatic**

Sloan OPTIMA® equipped Flushometers provide the ultimate in sanitary protection and automatic operation. There are no handles to trip or buttons to push. The Flushometer operates by means of an infrared sensor that adapts to its surroundings. Once the user enters the sensor's effective range and then steps away, the Flushometer Solenoid initiates the flushing cycle to flush the fixture.

**Hygienic**

User makes no physical contact with the Flushometer surface. Helps control the spread of infectious diseases. 24-hour Sentinel Flush keeps fixture fresh during periods of nonuse.

**Economical**

Automatic operation and a low flush volume provide water savings over other flushing devices. Reduces maintenance and operation costs.

**Practical**

Solid state electronic circuitry assures years of dependable, trouble-free operation. The operational components of the Flushometer are identical to a handle operated Royal® Flushometer, proven by more than 100 years of experience.

**Warranty**

3 year (limited)



Sloan Valve Company is buying renewable energy certificates to meet 100% of the company's purchased electricity use at its Franklin Park, Illinois facility.

**SLOAN**

Sloan Valve Company  
10500 Seymour Avenue  
Franklin Park, IL 60131  
Phone: 1-800-9-VALVE-9 (982-5839)  
or 1-847-671-4300  
Fax: 1-800-447-8329 or 1-847-671-4380  
www.sloanvalve.com

Copyright © 2011 Sloan Valve Company  
Rev. 0a (08/11)

This space for Architect/Engineer approval	
Job Name	Date
Model Specified	Quantity
Variations Specified	
Customer/Wholesaler	
Contractor	
Architect	

**DESCRIPTION**

Complete HEU system with concealed, sensor activated, Royal® OPTIMA® urinal Flushometer and vitreous china urinal fixture.

**Flush Cycle**

Model WEUS 1010.1311-0.125 ES-S (0.125 gpf/0.5 Lpf)

**ELECTRICAL SPECIFICATIONS**

- **Control Circuit**
  - Solid State
  - 24 VAC Input
  - 24 VAC Output
  - 8 Second Arming Delay
  - 24 Hour Sentinel Flush
- **OPTIMA® Sensor Range**
  - Nominal 15" – 30" (381 mm – 762 mm)
  - Self-adaptive Window ± 8" (203 mm)
- **Solenoid Operator**
  - 24 VAC, 50/60 Hz
- **Transformer Accessories**
  - EL-154 Transformer (120 VAC/24 VAC 50 VA)
  - EL-342 Transformer (240 VAC/24 VAC 50 VA)

**OPERATION**

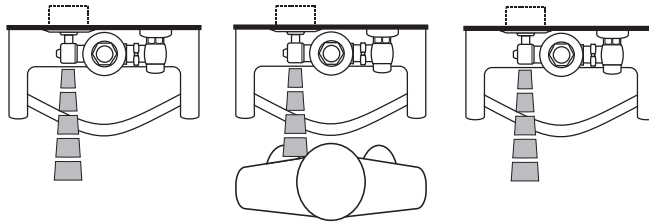

1. A continuous, invisible light beam is emitted from the OPTIMA® Sensor.
2. As the user enters the beam's effective range (15" to 30") the beam is reflected into the OPTIMA® Scanner Window and transformed into a low voltage electrical circuit. Once activated, the Output Circuit continues in a "hold" mode for as long as the user remains within the effective range of the sensor.
3. When the user steps away from the OPTIMA® Sensor, the circuit immediately initiates an electrical "one-time" signal that operates the Solenoid. This initiates the flushing cycle to flush the fixture. The Circuit then automatically resets and is ready for the next user.

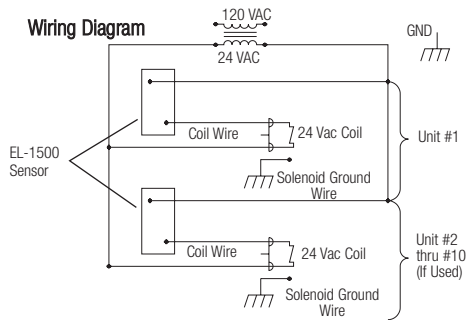
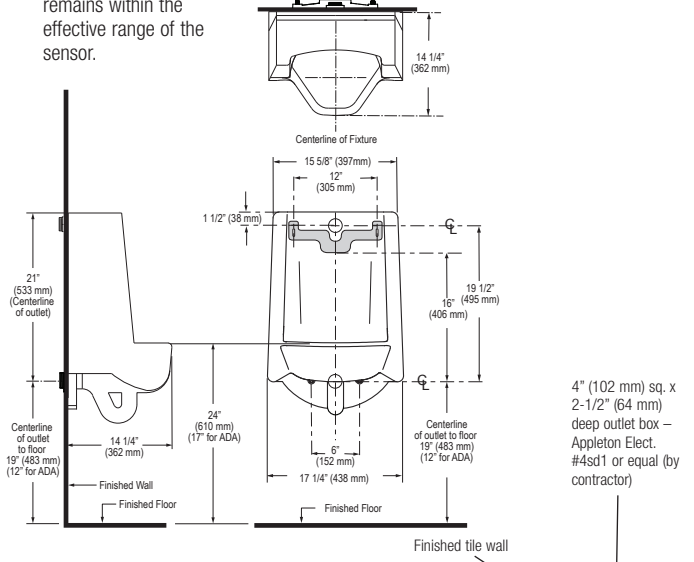
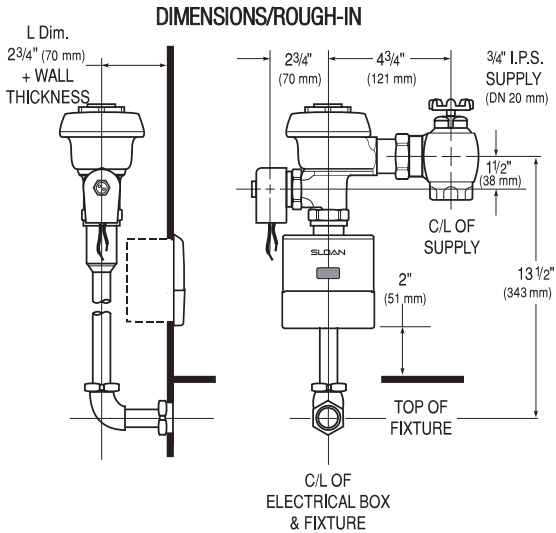

**Electrical Box Installation**  
*Sensor location and positioning is critical.* Failure to properly position the electrical boxes to the plumbing rough-in will result in improper installation and impair product performance. All tradesmen (plumbers, electricians, tile setters, etc.) involved with the installation of this product must coordinate their work to assure proper product installation. Installation template furnished with flushometer.

To ensure a perfect rough-in, Sloan recommends the use of the EL-518-A Flushometer electrical box positioning and support kit. Specify and order the EL-518-A kit separately. Consult factory for installation details.

