

OVERVIEW

Our LED Wall Pack provides even, bright lighting for outdoor settings. It is the ideal energy-efficient solution for public spaces, schools, hospitals, parking garages, outdoor walkways and more. With construction that prevents light pollution, saves energy and results in lower maintenance costs, outdoor spaces remain reliably lit for less cost over time.

KEY FEATURES

- Operation temperature: -4°F - 113°F
- Ignition time: Instant-on
- Photocell included (can be removed from circuit)
- 0-10V dimmable
- IP65-rated for use in wet conditions
- Heavy-duty aluminum casting

| | | |
|-------------|--|------|
| Catalog # | | Type |
| Project | | |
| Comments | | Date |
| Prepared by | | |



50,000
HOURS



PHOTOCELL
COMPATIBLE



POLYCARBONATE
LENS



ORDERING INFORMATION

| SOURCE | WATTAGE | TYPE | CCT | OPERATION |
|---------|----------------------------------|-----------------------------|------------|-------------------------------------|
| L = LED | 35 = 35W 50 = 50W 80 = 80W | WPT = Wall Pack Traditional | 50 = 5000K | D = 0-10V Dimming PC = Photocell |

*See ballast compatibility chart at www.amconservationgroup.com

L35-WPT-50-120/277-D-PC, L50-WPT-50-120/277-D-PC, L80-WPT-50-120/277-D-PC

SPECIFICATIONS

| CATALOG # | WATTS | CCT | LM | CRI | EFFICACY | VOLTAGE | DIM |
|-------------------------|-------|-------|------|-----|----------|----------|-------|
| L35-WPT-50-120/277-D-PC | 35W | 5000K | 4550 | ≥80 | 130 lm/W | 100-277V | 0-10V |
| L50-WPT-50-120/277-D-PC | 50W | 5000K | 5000 | ≥80 | 100 lm/W | 100-277V | 0-10V |
| L80-WPT-50-120/277-D-PC | 80W | 5000K | 8000 | ≥80 | 100 lm/W | 100-277V | 0-10V |

DIMENSIONS

PRODUCT

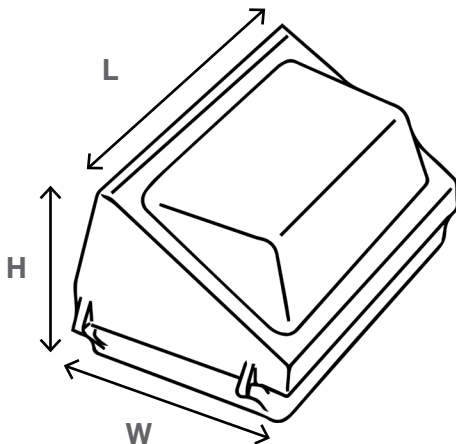

PACKAGING

Case

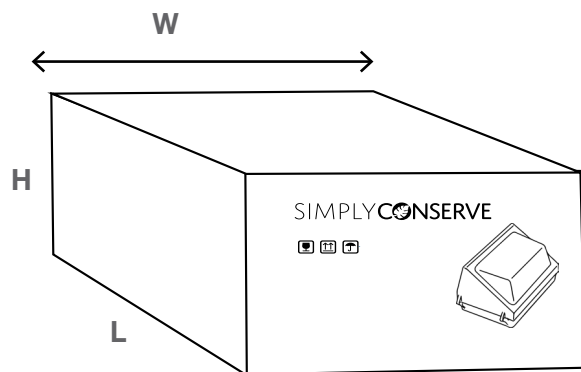

| CATALOG # | L | W | H |
|-------------------------|-------|------|------|
| L35-WPT-50-120/277-D-PC | 14.3" | 9.3" | 7.4" |
| L50-WPT-50-120/277-D-PC | 14.3" | 9.3" | 7.4" |
| L80-WPT-50-120/277-D-PC | 14.3" | 9.3" | 7.4" |

| CATALOG # | L | W | H | CASE QTY | GROSS WT |
|-------------------------|-------|-------|------|----------|----------|
| L35-WPT-50-120/277-D-PC | 15.2" | 11.0" | 9.6" | 1 | 9.6 lb |
| L50-WPT-50-120/277-D-PC | 15.2" | 11.0" | 9.6" | 1 | 9.6 lb |
| L80-WPT-50-120/277-D-PC | 15.2" | 11.0" | 9.6" | 1 | 9.6 lb |

5-Year Limited Warranty



AM Conservation ("AMC") warrants this product to be free from manufacturing defects for a period of five years from the date of consumer purchase or distribution by an energy conservation program, and has been properly installed, AMC will replace the product free of charge.

For warranty claims, please contact:

customer@amconservationgroup.com

To learn more, please visit:

www.amconservationgroup.com