

# ADJUSTABLE LED WALL PACK

L45/75-WPT-30/50-D-ADJ-120-277-PC

## OVERVIEW

Simply Conserve's field-adjustable traditional wall pack includes two switches on the unit which allow for adjustment of the lumen output and color temperature. This 9-in-1 wall pack allows for easy and flexible installation for new construction, remodel, and retrofit projects. Factory-installed photocell provides simple dusk-to-dawn control for exterior applications or add to existing controls with the included 0-10V dimming driver.

## KEY FEATURES

- Field-adjustable lumens and CCT
- For retrofit or new construction installation
- Wet location-rated
- L70-rated lifetime of 50,000 hours
- 0-10V dimmable
- Durable aluminum housing

Catalog #		Type
Project		
Comments		Date
Prepared by		



FIELD ADJUSTABLE



INTEGRATED PHOTOCELL



WET-RATED



50,000 HOURS



## ORDERING INFORMATION

SOURCE	WATTAGE	TYPE	CCT	INC. OPTIONS
L = LED	45/75 = 45W, 60W, 75W	WPT = Wall Pack Traditional	30/50 = 3000K, 4000K, 5000K	D = 0-10V Dimming ADJ = Adjustable PC = Photocell

## SPECIFICATIONS

CATALOG #	WATTS	CCT	LM	CRI	EFFICACY	VOLTAGE	DIM
L45/75-WPT-30/50-D-ADJ-120-277-PC	45/60/75	30/40/50K	6075/8100/10125	≥80	135 LPW	100-277V	0-10V

## DIMENSIONS

### PRODUCT

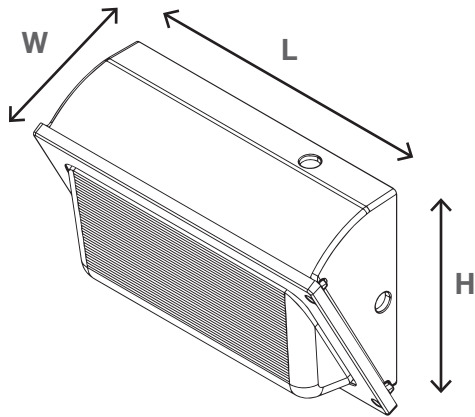

### PACKAGING

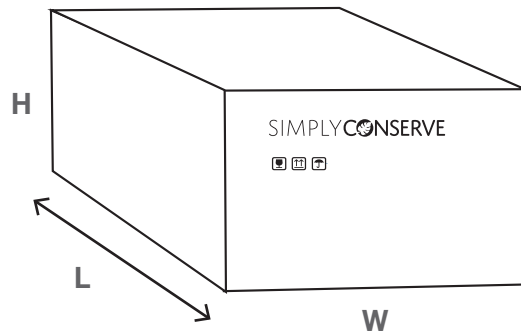

CATALOG #	L	W	H
L20/30-FP22-35/50-D-ADJ	14.0"	5.0"	9.0"

CATALOG #	L	W	H	CASE QTY	GROSS WT
L20/30-FP22-35/50-D-ADJ	16.1"	7.1"	11.0"	1	

### 5-Year Limited Warranty



If this wall pack fails to operate for a 5-year period under normal consumer use (12 hours/day, 7 days/week), from the date of purchase or distribution by an energy conservation program and has been properly installed, AM Conservation Group will replace the lamp free of charge.

#### For warranty claims, please contact:

customer@amconservationgroup.com

#### To learn more, please visit:

www.amconservationgroup.com