

OVERVIEW

Our LED Wall Pack with Photocell provides even, bright lighting for outdoor settings. It is the ideal energy-efficient solution for public spaces, schools, hospitals, parking garages, outdoor walkways and more. With construction that prevents light pollution, saves energy and results in lower maintenance costs, outdoor spaces remain reliably lit for less cost over time.

KEY FEATURES

- Operation temperature: -4°F - 113°F
- Storage temperature: -4°F - 113°F
- THD: 25%
- Ignition time: Instant-on
- Photocell included (can be removed from circuit)
- IP65-rated for use in wet conditions
- Heavy-duty aluminum casting

Catalog #		Type
Project		
Comments		Date
Prepared by		



50,000
HOURS



PHOTOCELL
COMPATIBLE



POLYCARBONATE
LENS



ORDERING INFORMATION

SOURCE	WATTAGE	TYPE	CCT	OPERATION
L = LED	35 = 35W 50 = 50W 80 = 80W	WPT = Wall Pack Traditional WPA = Wall Pack Adjustable	40 = 4000K 50 = 5000K	PC = Photocell F = Full Cut-Off

*See ballast compatibility chart at www.amconservationgroup.com

SPECIFICATIONS

L35WPT50F-PC, L50WPT50F-PC, L80WPT50F-PC

CATALOG #	WATTS	CCT	LM	CRI	EFFICACY	VOLTAGE	PF	HZ	MH EQUIVALENT	DIM
L35WPT50F-PC	35W	5000K	4550	≥80	130 lm/W	100-277V	≥0.9	60	100W	No
L50WPT50F-PC	50W	5000K	5000	≥80	100 lm/W	100-277V	≥0.9	60	125W	No
L80WPT50F-PC	80W	5000K	8000	≥80	100 lm/W	100-277V	≥0.9	60	175W	No

DIMENSIONS

PRODUCT

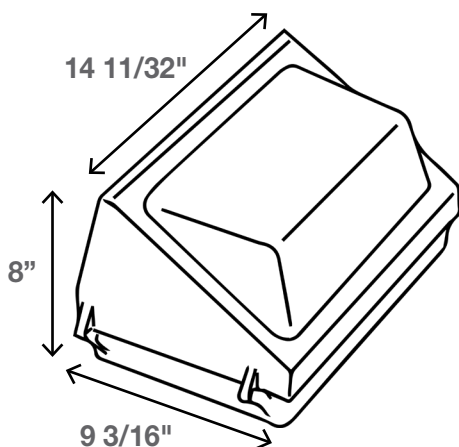

PACKAGING

Case

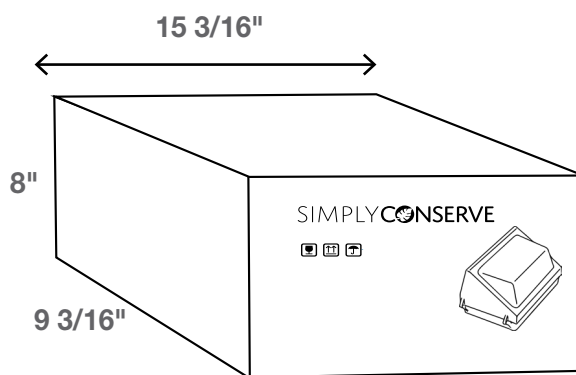

1/Master Case



Gross WT: 10 lb.

5-Year Limited Warranty



If this wall pack fails to operate for a 5-year period under normal consumer use (6 hours/day, 7 days/week), from the date of purchase or distribution by an energy conservation program and has been properly installed, AM Conservation Group will replace the lamp free of charge.

For warranty claims, please contact:

customer@amconservationgroup.com

To learn more, please visit:

www.amconservationgroup.com