

### OVERVIEW

Simply Conserve's Mini Wall Pack is a great choice for adding or upgrading outdoor security lighting. It's ideal for garages, loading bays, multifamily complexes, hospitality, and office buildings. The integrated photocell allows for dusk-to-dawn operation out of the box. Durable plastic housing and ETL wet-rated listing allows the fixture to withstand the exterior elements.

Catalog #		Type
Project		
Comments		Date
Prepared by		

### KEY FEATURES

- Suitable for retrofit or new construction installation L70-Rated lifetime of 35,000 hours
- CRI >80
- Polycarbonate lens construction
- 120V operation



WET-RATED

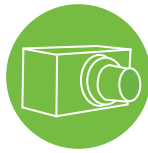

INTEGRATED PHOTOCELL



POLYCARBONATE LENS



### ORDERING INFORMATION

SOURCE	WATTAGE	FIXTURE TYPE	CCT	OPTIONS
L = LED	15W	MWP = Mini Wall Pack	40 = 4000K	PC = Photocell

**SPECIFICATIONS**

CATALOG #	WATTS	CCT	LUMENS	EFFICACY	CRI	VOLTAGE	DIM
L15-MWP-40-120-PC	15	4000K	1050	70 LPW	>80	120	NO

**DIMENSIONS**

**PRODUCT**

**CASE**

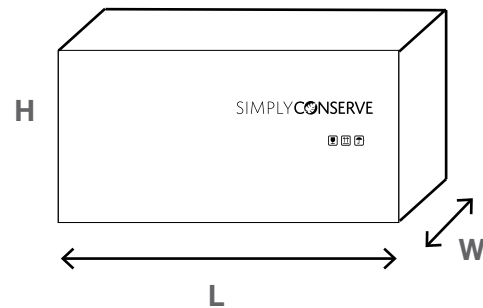
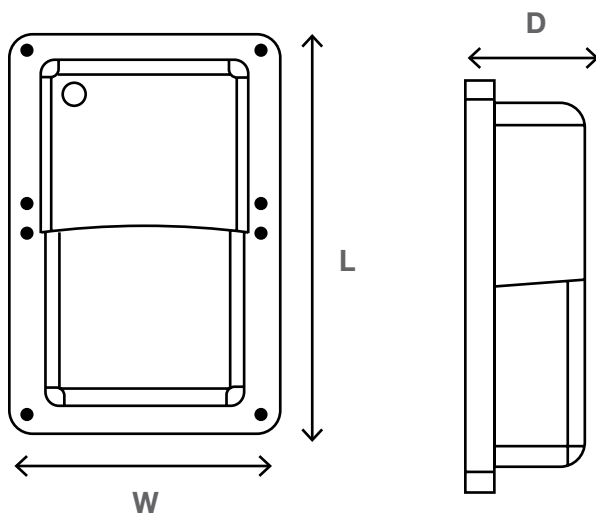

CATALOG #	L	W	D
L15-MWP-40-120-PC	11.4"	7.7"	1.6"

CATALOG #	L	W	H	CASE QTY	GROSS WT
L15-MWP-40-120-PC	18.7"	16.0"	12.2"	10	XXX

**5-Year Limited Warranty**



AM Conservation Group ("AMCG") warrants this product to be free from manufacturing defects for a period of five years from the date of consumer purchase or distribution by an energy conservation program, and has been properly installed, AMCG will replace the mini wall pack free of charge.

**For warranty claims, please contact:**

customer@amconservationgroup.com

**To learn more, please visit:**

www.amconservationgroup.com