

SIMPLY CONSERVE

12W LED PL LAMP (VERTICAL)

L12PL40G24QV, L12PL50G24QV



This Vertical 12W LED PL Lamp offers the ideal plug-and-play solution for task lighting. Its shatter-resistant, mercury-free design delivers exceptional durability, and its cool white light efficiently illuminates commercial spaces. A 50,000-hour lifespan coupled with cutting-edge energy efficiency technology creates noticeable savings for users. Note that a new or existing ballast is required for operation.



POTENTIAL LIFETIME SAVINGS: 300 KWH/\$33*

*Compared to an 18W CFL, 3 hours per day, ~ \$0.11/Kw

PRODUCT FEATURES OVERVIEW



DAMP-RATED



MERCURY-FREE



INSTANT-ON/OFF



NON-DIMMABLE



5-YEAR LIMITED WARRANTY*

*AM Conservation Group, Inc. guarantees to the original purchaser or recipient of this lamp that it is free from defects in material and workmanship for five years from the date of purchase. Warranty is limited to repair or replacement of the lamp. Lamps being returned must include proof of purchase.

Rated Power (W):	12W
Color Temp (CCT):	4000K, 5000K
Typical Lumens (lm):	1200 lm
Efficacy (lm/w):	100 lm/w
Beam Angle:	150°
Operation Temperature:	-4°F - 104°F
Storage Temperature:	-4°F - 104°F
Input Voltage (V):	120-277V
Power Factor:	> 0.9
THD:	20%
Ignition Time:	Instant-on
Line Frequency:	60 Hz
Dimmable:	No
Safety Certification:	ETL
DLC-Listed:	Yes
Base / Cap:	G24Q, GX24Q

Product Life:	50,000 Hrs
Target Replacement:	18W/7T4/G24Q
Direct Replacement/Ballast Compatible:	New or existing ballast is required for operation
	<ul style="list-style-type: none"> • Shatter Resistant • Mercury-Free • Damp-Rated

12W LED PL LAMP (VERTICAL) | L12PL40G24QV, L12PL50G24QV

SPECIFICATIONS BY MODEL

ITEM #	VOLTAGE	WATTS	CCT	LUMENS	PF	CRI	LIFETIME	BEAM ANGLE	BASE	CERTIFICATIONS
L12PL40G24QV	120-277V	12W	4000K	1200 lm	≥0.9	≥80	50,000 Hrs	150	G24Q, GX24Q	DLC Standard
L12PL50G24QV	120-277V	12W	5000K	1200 lm	≥0.9	≥80	50,000 Hrs	150	G24Q, GX24Q	DLC Standard

MODEL SELECTION

FAMILY	WATTAGE	LAMP TYPE	BASE	CCT.	ORIENTATION
L = LED Linear	9 = 9W 12 = 12W	PL = PL Lamp	G24Q/GX24Q GX23-2 G24D	35 = 3500K 40 = 4000K 50 = 5000K	V = Vertical H = Horizontal

DIMENSIONS

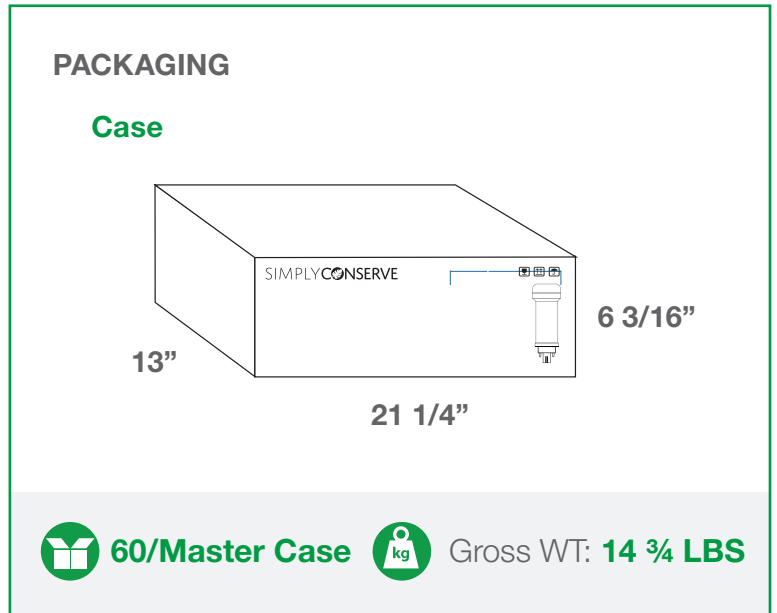
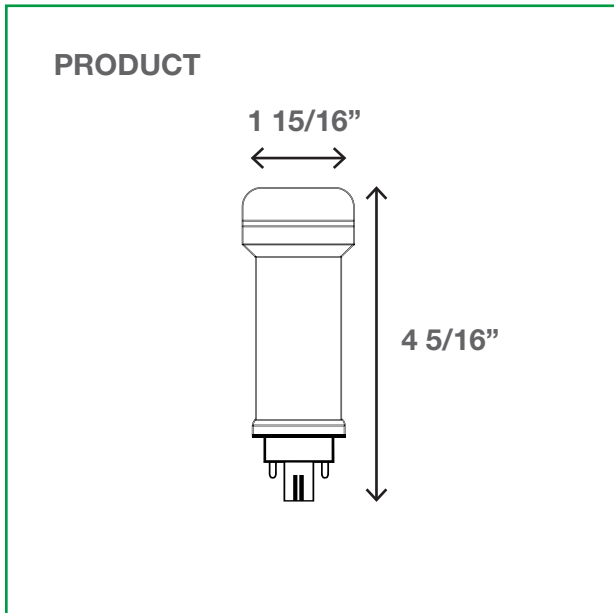

AM CONSERVATION GROUP//COMMERCIAL LIGHTING

12W LED PL LAMP (VERTICAL) | L12PL40G24QV, L12PL50G24QV

BALLAST COMPATIBILITY

KEY

✓	COMPATIBLE
✗	UN-COMPATIBLE
/	NOT TESTED

NO.	BRAND	PART #	VIN	START METHOD	# OF LAMPS	LAMP CONNECTION	1 LAMP		2 LAMP	
							120 VAC	277 VAC	120 VAC	277 VAC
1	Philips	ICF-2S18-H1-LD	120-277	RS	2	Parallel	✓	✓	✓	✓
2	Philips	ICF-2S26-H1-LD	120-277	RS	2	Parallel	✓	✓	✓	✓
3	Philips	ICF-2S42-M2-LD	120-277	RS	2	Parallel	✓	✓	✓	✓
4	Philips	REZ-1Q18-M2-BS	120	RS	1	N/A	✓	✓	/	/
6	Triad	Triad C213UNVME	120-277	RS	2	Parallel	✓	✓	✓	✓
7	Triad	Triad C218UNVME	120-277	RS	2	Parallel	✓	✓	✓	✓
8	Triad	Triad C2642UNVME	120-277	RS	2	Parallel	✓	✓	✓	✓
9	Osram	QTP 2*26CF/UNV DM	120-277	RS	2	Parallel	✓	✓	✓	✓
10	Hatch Lighting	HC226PS/UV/D	120-277	RS	2	Parallel	✓	✓	✓	✓
12	Energy Savings	ES-2/1-CFQ-18-UNV-C	120-277	RS	2	Parallel	✓	✓	✓	✓
14	Robertson	PSM 226CQMVDWCE(3P20145)	120-277	RS	2	Parallel	✓	✓	✓	✓
15	Howard	EP2/26CF/MV/2	120-277	RS	2	Parallel	✓	✓	✓	✓
16	Howard	EP2/42CF/MV/2	120-277	RS	2	Parallel	✓	✓	✓	✓
17	Sola	E-724-U-226-MI-S	120-277	PS	2	Parallel	✓	✓	✓	✓
18	Keystone	CAT.NO.KTEB-213-UV- RS-DW	120-277	PS	2	Parallel	✗	✗	✓	✓
19	Keystone	CAT.NO.KTEB-213-UV- PS-DW	120-277	RS	2	Parallel	✗	✗	✓	✓
20	Keystone	CAT.NO.KTEB-218-UV- RS-DW	120-277	RS	2	Parallel	✗	✗	✓	✓

AM CONSERVATION GROUP//COMMERCIAL LIGHTING

12W LED PL LAMP (VERTICAL) | L12PL40G24QV, L12PL50G24QV

							1 LAMP		2 LAMP	
NO.	BRAND	PART #	VIN	START METHOD	# OF LAMPS	LAMP CONNECTION	120 VAC	277 VAC	120 VAC	277 VAC
21	Keystone	CAT.NO.KTEB-218-UV-PS-DW	120-277	RS	2	Parallel	✗	✗	✓	✓
22	Keystone	CAT.NO.KTEB-226-UV-RS-DW	120-277	RS	2	Parallel	✗	✗	✓	✓
25	Keystone	CAT.NO.KTEB-226-UV-PS-DW	120-277	RS	2	Parallel	✗	✗	✓	✓
26	Keystone	CAT.NO.KTEB-242-UV-RS-DW	120-277	RS	2	Parallel	✗	✗	✓	✓
27	Keystone	CAT.NO.KTEB-242-UV-PS-DW	120-277	RS	2	Parallel	✗	✗	✓	✓