

OVERVIEW

The Simply Conserve® field-adjustable commercial downlight includes two switches on the unit which allow for adjustment of the input power, lumen output, and color temperature of 3000K/3500K/4000K. This downlight allows for easy installation in new construction, remodel and retrofit projects. Its 90+ CRI and frosted lens allow for true color rendering for vivid colors throughout, and glare-free lighting makes it ideal for commercial use in retail spaces, hospitals, offices, and airports. Features include: 0-10V dimming, 3CCT selectable, 3 wattage selection, wet rated, JA certification, IC rating, and ENERGY STAR® rating.

Catalog #		Type
Project		
Comments		Date
Prepared by		

KEY FEATURES

- Field-adjustable lumen and CCT
- Suitable for retrofit or new construction installation
- Wet location-, IC- and airtight-rated
- Matte white, smooth trim finish
- 0-10V dimmable
- Spring-loaded retention clips
- Complies with the requirements of California Title 24 Part 6



FIELD
ADJUSTABLE



IC-RATED



WET-
RATED



50,000
HOURS



BEAM
ANGLE



ORDERING INFORMATION





SOURCE	WATTAGE	LAMP TYPE	SIZE	CCT	INC. OPTIONS
L = LED	7/18 = 7W/10W/18W 10/22 = 10W/15W/22W	DL = Downlight	6 = 6 Inch 8 = 8 Inch	30K/35K/40K Adjustable	D = Dimmable ADJ = Adjustable

*See ballast compatibility chart at www.amconservationgroup.com

SPECIFICATIONS

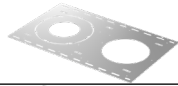
CATALOG #	WATTS	CCT	LUMENS	CRI	VOLTAGE
L7/18-DL6/35/50-D-ADJ	7/10/18W	30K/35K/40K	700/1000/1500	≥90	120-277V
L10/22-DL8-35/50-D-ADJ	10/15/22W	30K/35K/40K	1000/1500/2000	≥90	120-277V

ACCESSORIES

IMAGE	CATALOG #	DESCRIPTION	SIZE
	LDL-JOIST	New Construction Plate, Stud/Joist	6"/8"/9.5"
	LDL-TGRID	New Construction Plate, T-Grid Ceiling	6"/8"/9.5"
	LDL-GR6	Goof Ring 6", 8-2/4" to 10-1/2", Max. 9"	6"
	LDL-GR8	Goof Ring 8", 10-1/4" to 12-1/2", Max 10-15/16"	8"

DIMENSIONS

PRODUCT

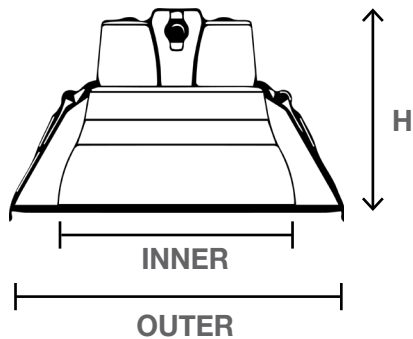

CASE

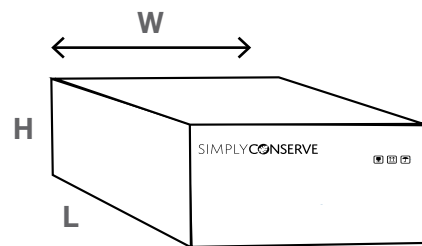

CATALOG #	H	INNER	OUTER
L7/18-DL6/35/50-D-ADJ	5 1/8"	6 1/4"	8 1/4"
L10/22-DL8-35/50-D-ADJ	5 7/8"	7 7/8"	10 1/4"

CATALOG #	L	W	H	CASE QTY	GROSS WT
L7/18-DL6/35/50-D-ADJ	17.64"	9.05"	12.68"	4	6.6 lbs.
L10/22-DL8-35/50-D-ADJ	21.58"	11.02"	14.09"	4	7.7 lbs.

5-Year Limited Warranty



If this downlight fails to operate for a 5-year period under normal consumer use (6 hours/day, 7 days/week), from the date of purchase or distribution by an energy conservation program and has been properly installed, AM Conservation Group will replace the lamp free of charge.

For warranty claims, please contact:

customer@amconservationgroup.com

To learn more, please visit:

www.amconservationgroup.com